



Automation Light Grids

Advanced automation light grids,
standard automation light grids,
smart light grids

QUERO
AUTOMATION

SICK

Sensor Intelligence.

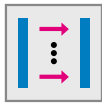

Sender/
receiver
system

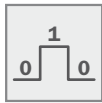

Switching

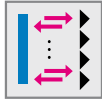

Retro-reflective
system



Measuring

At SICK, you will find the perfect automation light grid to suit your requirements and application.



Functions

Requirements

Applications

B	Advanced ALG ¹⁾						Limiting range in m	Beam separation in mm	Detection height in mm	Applications					
	MLG	B-8													
	MLG	B-8	●		○	●	12	10, 20, 25, 30, 50	100 ... 3,140	●	○		○	●	MLG
	XLG	B-64	●			●	12	10, 30, 50	100 ... 2,000	○		●			XLG
C	WLG	C-8		●	●	○	1.5	12,5	87.5	○	●				WLG
	HLG	C-14	●		●		2	2	50		●				HLG
	ELG	C-20	●		●		17	10, 30, 60	150 ... 3,330		●	●		○	ELG
D	PLG	C-38		●	●		2	30, 60	60, 120, 210, 270, 360, 420		●		●		PLG
	SAS	D-8	●		●		4	40	120 ... 600		●				SAS
	SPL	D-20	●		●		3	40	120 ... 440			●			SPL
	SGS	D-30	●		●		10	40, 80	600 ... 1,400		●	●			SGS

¹⁾ ALG = Automation light grids.
 ● = Main function/main application.
 ○ = Possible function/application.



Position determination

Jut-out control | Height measurement |
Profile detection | Sag control



Object presence

Access control | Reject control |
Edge control



Application at toll booths and on industrial doors

Vehicle classification | Vehicle separation |
Industrial doors

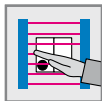

Pick-to-light

Operator guidance |
Error-free commissioning







Light grid frame

Volume measurement |
Operator guidance | Reject control

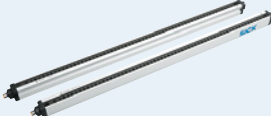
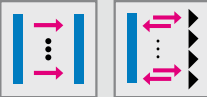
We offer off-the-shelf and tailor-made solutions to fit your exact needs.

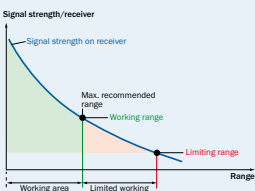

	<p>General information About SICK</p>	<p>A</p>
	<p>Advanced automation light grids MLG XLG</p> 	<p>B</p>
	<p>Standard automation light grids WLG HLG ELG PLG</p> 	<p>C</p>
	<p>Smart light grids SAS SPL SGS</p> 	<p>D</p>
	<p>Accessories</p> 	<p>E</p>
	<p>Appendix Glossary</p> 	<p>F</p>

Sensor Intelligence is our promise

SICK sensor solutions for industrial automation are the result of exceptional dedication and experience. From development all the way to service: The people at SICK are committed to investing all their expertise in providing with the very best sensors and system solutions possible.

A company with a culture of success

Approximately 5,000 people are on staff, with products and services available to help SICK sensor technology users increase their productivity and reduce their costs. Founded in 1946 and headquartered in Waldkirch, Germany, SICK is a global sensor specialist with more than 50 subsidiaries and representations worldwide. Our exemplary corporate culture

fosters an optimum work-life balance, thus attracting the best employees from all over the world. SICK is one of the best employers – we have been among the winners of the prestigious German “Great Place to Work” award for many years in succession.



Innovation for the leading edge

SICK sensor systems simplify and optimize processes and allow for sustainable production. SICK operates thirteen research and development centers all over the world. Co-designed with customers and universities, our innovative sensor products and solutions are made to give a decisive edge. With an impressive track record of innovation, we take the key parameters of modern production to new levels: reliable process control, safety of people and environmental protection.



A corporate culture for sustainable excellence

SICK is backed by a holistic, homogeneous corporate culture. We are an independent company. And our sensor technology is open to all system environments. The power of innovation has made SICK one of the technology and market leader – sensor technology that is successful in the long term.



Sensor Intelligence for all requirements

A

SICK is a renowned expert in many industries, and is entirely familiar with the critical challenges they face. While speed, accuracy and availability take center stage in all industries, technical implementations vary greatly. SICK puts its vast experience to use to provide with precisely the solution you need.

For applications worldwide

Hundreds of thousands of installations and applications go to prove that SICK knows the different industries and their processes inside out. This tradition of uncompromising expertise is ongoing: As we move into the future, we will continue to design,

implement and optimize customized solutions in our application centers in Europe, Asia and North America. You can count on SICK as a reliable supplier and development partner.

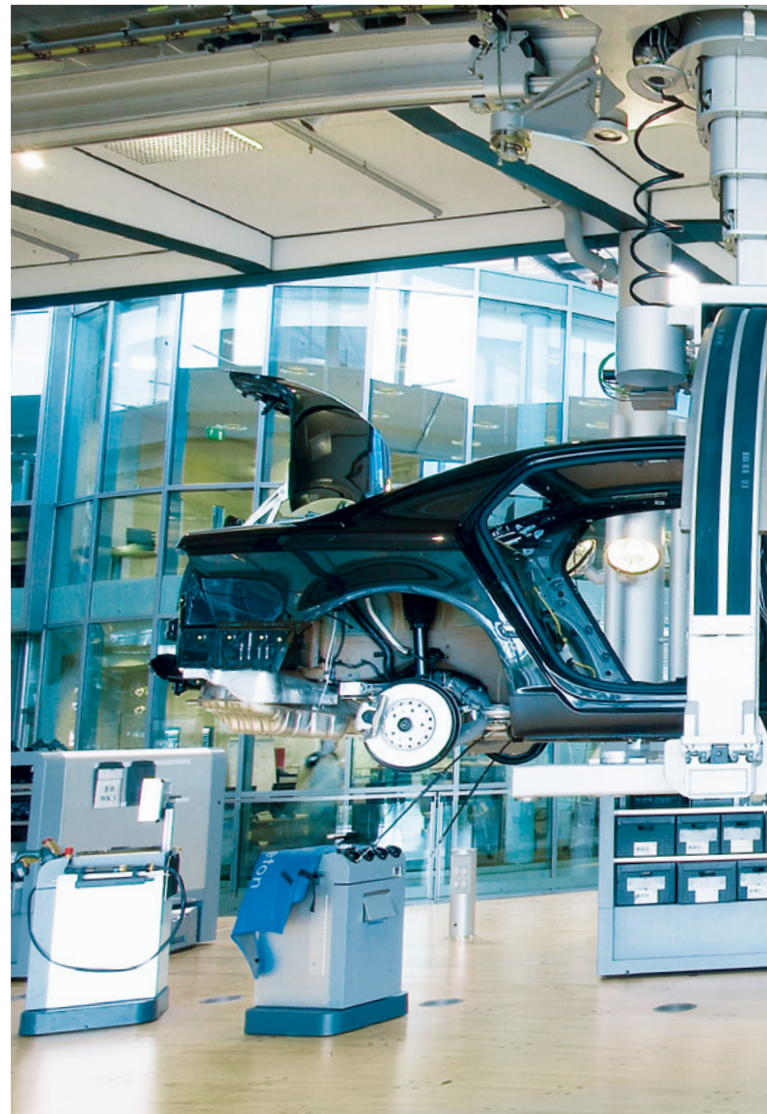

For your specific industry

With a track record of proven expertise in a great variety of industries, SICK has taken quality and productivity to new heights. The automotive, pharmaceutical, electronics and solar industries are just a few examples of sectors that benefit from our know-how. In addition to increasing speed and improving traceability in warehouses and distribution centers, SICK solutions provide accident protection for automated guided vehicles. SICK system solutions for analysis and flow measurement of gases and liquids enable environmental protection and sustainability in, for example, energy production, cement production or waste incineration plants.

For performance across the board

SICK provides the right technology to respond to the tasks involved in industrial automation: measuring, detecting, monitoring and controlling, protecting, networking and integrating, identifying, positioning. Our development and industry experts continually create groundbreaking innovation to solve these tasks.



www.sick.com/Industries



A

For safety and productivity: SICK LifeTime Services

SICK LifeTime Services is a comprehensive set of high-quality services provided to support the entire life cycle of products and applications from system design all the way to upgrades. These services increase the safety of people, boost the productivity of machines and serve as the basis for our customers' sustainable business success.



Benefit from an array of services

Each of our products and solutions is accompanied by a comprehensive range of services tuned precisely to the requirements of the product or solution – along its entire life cycle. Backed by extensive industry know-how and more than sixty

years of experience, LifeTime Services stand for maximum availability and an exceptional service life of our products and solutions.





Training & Education

- User training
- Seminars
- WebTraining



Product & System Support

- Commissioning
- Spare parts and repairs
- Remote support
- Hotline



Verification & Optimization

- Barcode checks
- Consulting/Engineering service
- Inspection
- Maintenance
- Accident analysis
- Stop time measurement
- Noise measurement



Consulting & Design

- System inspection
- Risk assessment
- Safety concepts
- Feasibility studies
- Software and hardware design



Upgrade & Retrofits

- Machine conversion
- Sensor upgrades
- Sensor replacements
- Retrofitting of technology

 www.sick.com/service



B

For demanding requirements

Advanced automation light grids are ideal for more complex applications. They come in several different beam separation options, a range of detection heights and output configurations. These light grids can be used for material handling on conveyors, automated storage and retrieval system applications, order fulfilment, and more. For example, in pallet verification applications, maximum height and pallet overhang can be measured. This data can be forwarded to the PLC via bus systems.





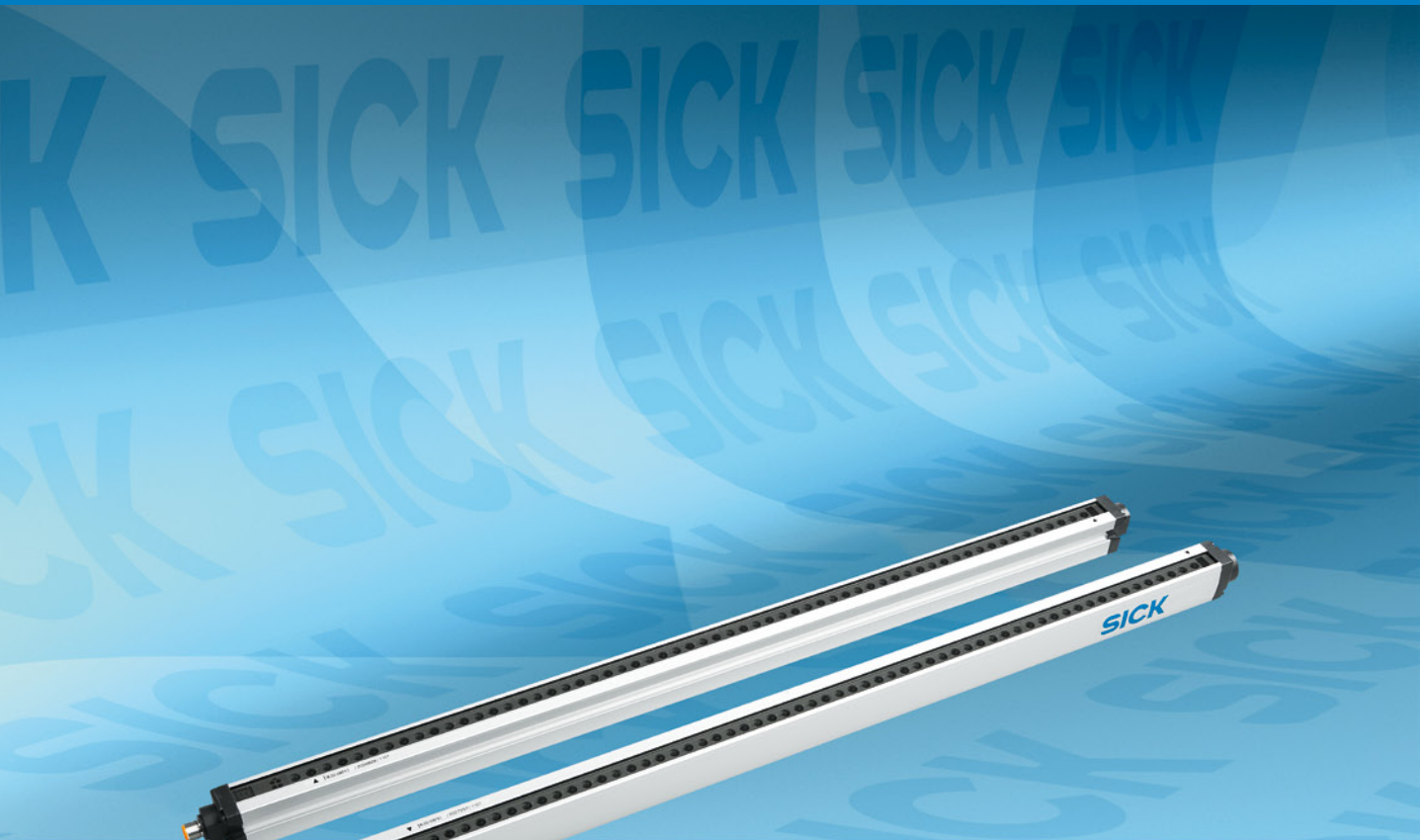

Your benefits

- Sensors with high quality and performance for customer-oriented solutions
- Highest immunity to ambient light, eliminates false trips
- Flexible programming for customized solutions, saves costs
- Easy-to-see status information helps avoid interrupting operation, saves costs
- Different beam separation options, detection heights and output configurations ensure a reliable solution





Advanced automation light grids

	Technology/applications and industries	B-2
	Product family overview	B-6
	MLG Standard. For switching applications	B-8
	MLG Programmable For customized solutions	B-20
	MLG PROFIBUS For easy integration	B-32
	MLG CANopen. For fast integration	B-44
	MLG Analog Output. Easy measuring with analog outputs	B-54
	XLG Programmable. Reliable measurement even in sunlight	B-64

Modular multi talents – personalize your own light grid

B



Whether pre-configured or programmed by the customer, the range of possibilities is endless with advanced automation light grids. On request, SICK will fully customize your light grid – both hardware and software.

Modular construction – enables you to decide for yourself!

Advanced automation light grids are configured using a modular design principle. Detection height, resolution and range can be chosen to meet your requirements.

Detection height

Minimum = 100 mm
Maximum = 3,140 mm

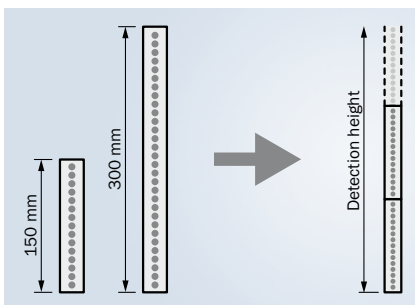

Simple interconnection of optics modules with lengths of 150 mm or 300 mm. Monitoring height determines how many modules to use.

Beam separation

Minimum = 10 mm
Maximum = 50 mm

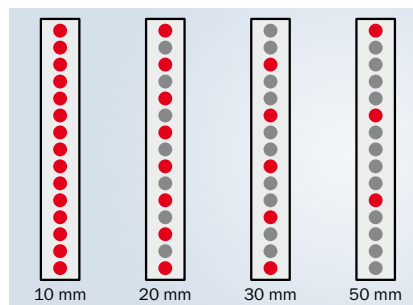

Beam separation varies depending on how the optics modules are equipped with LEDs. The smaller the beam separation, the higher the resolution will be. There is also an MLG variant with a beam separation of 25 mm.

Range

Minimum = 0 m^{*)}
Limiting scanning range = 12 m

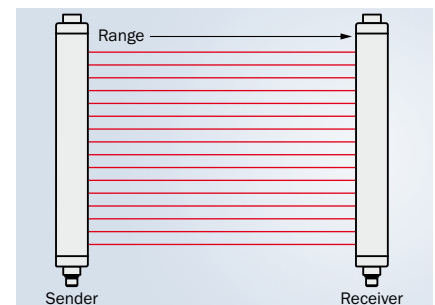

A choice of ranges completes the modular hardware configuration.

^{*)} With parallel beam.

Interfaces/bus functionality

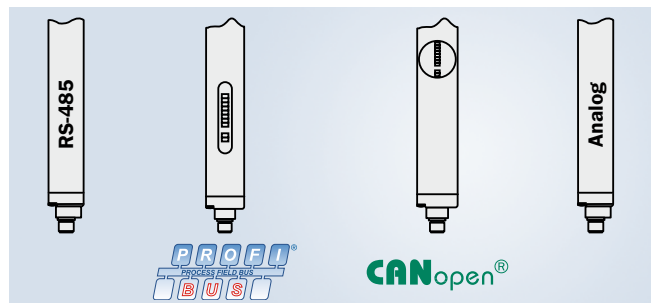

Interfaces integrated in each device mean there is no need for any additional hardware. Addressing of each bus-compatible MLG is via a separate address.

Basic software functions

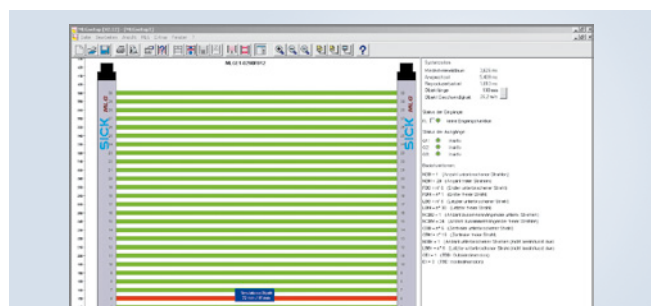

MLG setup software comes with multitude of pre-programmed basic functions e.g., “Last Beam Blocked (LBB)” for measurement of heights.

Cross beam function

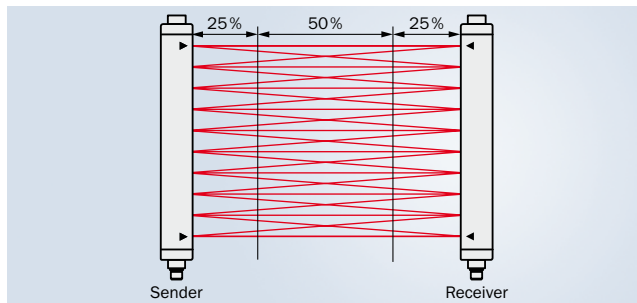

Due to the cross beam function, the resolution of the light grids can be increased even further. The resolution in the central area between sender and receiver is twice as high. This enables even small objects to be reliably detected.

B

Standard or programmable



The MLG Standard is used for **switching** applications, however, programmable variants are used for **measuring** applications.

XLG – anti-glare light grid with light protection factor

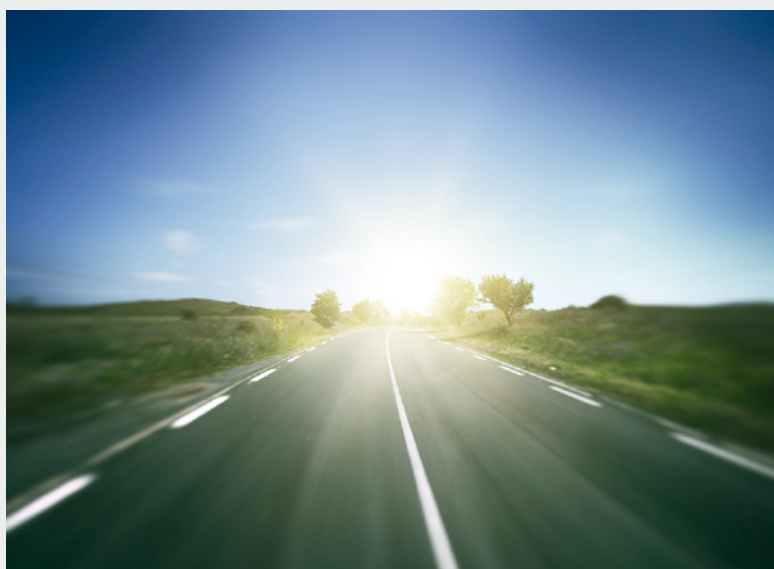

The XLG advanced automation light grid from SICK is outstanding for use in **outdoor areas**. It is one of the first **anti-glare light grids** on the market. A special optic ensures each light beam arrives at the receiver and is detected.

Yet, that's not all: As an optional accessory, SICK has developed a **protection housing**, which provides additional protection against dirt for the light grid.



MLG – Logistics

B



Modular light grids (MLG) are used in various logistics areas. Particularly in automatic warehousing systems, checking for projections with height measurement is essential. In mail distribution centers, they determine the position of parcels on the conveyor and transfer the data to a PLC via bus systems. With their integrated basic functions, they enable dynamic warehousing systems to optimize workflow and space.

MLG – Airports



MLG automation light grids are used at turnstiles in airports to ensure no unauthorized persons enter secure airport areas or exit the turnstiles in the wrong direction. They also make passing objects over the turnstiles virtually impossible.

MLG – Warehousing



To attain optimal storage compression while enabling flexible warehousing strategies at the same time, it is essential that goods for automatic storage are checked for height and to ensure there is no overhang. That way they can be assigned to the correct storage space and ensure collision-free lift transportation. The MLG automation light grid combined with “tray overhang” software – specially developed by SICK – enable relevant object dimensions to be captured.

XLG – Wood



Diameter detection

The XLG advanced automation light grid detects log diameter so that the log is centered in the bark stripper.



B



Log measurement



XLG advanced automation light grids are used to measure the length and diameter of logs. Using the acquired data, any large roots on the log are detected and the log is then fed via the bypass to a butt reducer.

XLG – Traffic



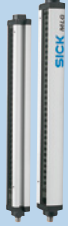
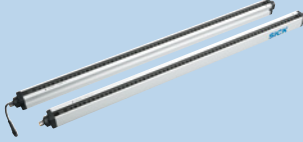

Key tasks for toll systems are the fast separation of vehicles and their unique classification. The XLG's absolute immunity to infrared light and sunlight, the optional heated protective housing and its scratch- and weather-resistant front screen ensure a high level of reliability over long periods of time, even in the most adverse outdoor conditions.

Product family overview

	 <p>MLG Standard</p> <p>For switching applications</p>	 <p>MLG Programmable</p> <p>For customized solutions</p>	 <p>MLG PROFIBUS</p> <p>For easy integration</p>		
Technical data overview					
Beam separation	10 mm 20 mm 30 mm 50 mm	10 mm 20 mm 30 mm 50 mm	10 mm 20 mm 30 mm 50 mm		
Detection height	100 mm ... 3,140 mm				
Working range	5 m 8.5 m	5 m 8.5 m	5 m 8.5 m		
Switching output	PNP NPN	PNP NPN RS-485	PNP PROFIBUS DP		
Connection type	Connector M12, 5-pin	Connector M12, 8-pin Connector M12, 12-pin Terminals	Connector M12, 5-pin Connector M12, 8-pin		
Response time	Parallel beam: 1.5 ms ... 37 ms Cross beam: depending on type				
Dimensions (W x H x D)	34 mm x 214 mm x 29 mm ... 34 mm x 3,335 mm x 29 mm	34 mm x 214 mm x 29 mm ... 34 mm x 3,335 mm x 29 mm	34 mm x 214 mm x 29 mm ... 34 mm x 3,335 mm x 29 mm		
At a glance					
	<ul style="list-style-type: none"> Up to 3 x PNP or NPN switching outputs Resolutions of 10 / 20 / 30 / 50 mm and customer-specific resolutions Working range up to 8.5 m Detection heights of over 3 m and up to 240 beams possible Short response time < 3 ms Automatic teach during power on <ul style="list-style-type: none"> Resolutions of 10 / 20 / 30 / 50 mm and customer-specific resolutions Working range up to 8.5 m Detection heights of over 3 m and up to 240 beams possible Short response time < 3 ms External teach-in for optimal sensitivity settings Easy-to-use setup software for customized applications <ul style="list-style-type: none"> Integrated PROFIBUS interface Resolutions of 10 / 20 / 30 / 50 mm and customer-specific resolutions Working range up to 8.5 m Detection heights of over 3 m and up to 240 beams possible Short response time < 9 ms External teach-in for optimal sensitivity settings 				
Further information					
Applications					
Detailed information	→ B-8	→ B-20	→ B-32		

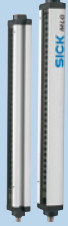
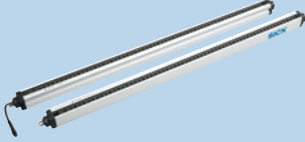
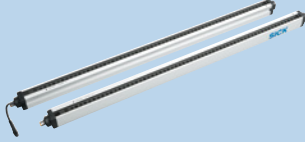
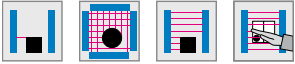
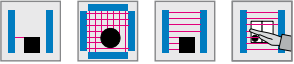
B

 <p>MLG CANopen</p>	 <p>MLG Analog Output</p>	 <p>XLG Programmable</p>
<p>For fast integration</p>	<p>Easy measuring with analog outputs</p>	<p>Reliable measurement even in sunlight</p>
<p>10 mm 20 mm 30 mm 50 mm</p>	<p>10 mm 20 mm 30 mm 50 mm</p>	<p>10 mm 20 mm 30 mm 50 mm</p>
<p>100 mm ... 3,140 mm</p>	<p>100 mm ... 3,140 mm</p>	<p>100 mm ... 1,990 mm</p>
<p>5 m 8.5 m</p>	<p>5 m 8.5 m</p>	<p>5 m</p>
<p>PNP CANopen</p>	<p>PNP NPN 2 x analog outputs</p>	<p>PNP NPN RS-485</p>
<p>Connector M12, 8-pin</p>	<p>Connector M12, 8-pin Connector M12, 12-pin Terminals</p>	<p>Connector M12, 8-pin Terminals</p>
<p>Parallel beam: 9 ms ... 57 ms Cross beam: depending on type</p>	<p>Parallel beam: 1.5 ms ... 37 ms Cross beam: depending on type</p>	<p>Parallel beam: 1.5 ms ... 24 ms Cross beam: depending on type</p>
<p>34 mm x 214 mm x 29 mm</p>	<p>34 mm x 214 mm x 29 mm</p>	<p>34 mm x 214 mm x 29 mm</p>
<p>... 34 mm x 3,335 mm x 29 mm</p>	<p>... 34 mm x 3,335 mm x 29 mm</p>	<p>... 34 mm x 2,125 mm x 29 mm</p>
<ul style="list-style-type: none"> • Integrated CANopen interface • Resolutions of 10 / 20 / 30 / 50 mm and customer-specific resolutions • Working range up to 8.5 m • Detection heights of over 3 m and up to 240 beams possible • Short response time of < 9 ms • Teach algorithm for optimal sensitivity settings in difficult applications 	<ul style="list-style-type: none"> • Two analog outputs: voltage to current • Resolutions of 10 / 20 / 30 / 50 mm and customer-specific resolutions • Working range up to 8.5 m • Detection heights of over 3 m and up to 240 beams possible • Short response time of < 3 ms possible • Teach algorithm for optimal sensitivity settings in difficult applications, such as measuring translucent objects • Easy-to-use setup software for customized applications with new features • Software tools, such as height measurement, zoning, hole detection, and presence control make implementation of complex solutions achievable 	<ul style="list-style-type: none"> • Up to 6 x PNP or NPN switching outputs and two switching inputs • Resolutions of 10 / 20 / 30 / 50 mm and customer-specific resolutions • Working range up to 5 m • Detection heights of over 3 m and up to 150 beams possible • Short response time < 3 ms • External teach-in for optimal sensitivity settings • Highest immunity to sunlight • Scratch-resistant front lens
		
<p>→ B-44</p>	<p>→ B-54</p>	<p>→ B-64</p>

For switching applications

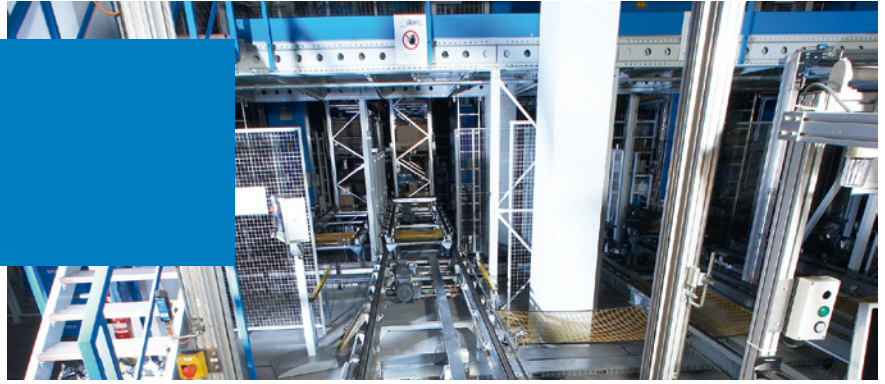

B



Additional information

Detailed technical data B-9
 Ordering information B-10
 Dimensional drawing B-14
 Adjustments B-16
 Connection type and diagram . . . B-16
 Recommended accessories B-17
 Special functions B-18

Product description

The MLG Standard offers a high level of switching flexibility in applications. The standard models perform like a typical through-beam photoelectric sensor and provide an output if any of the beams is interrupted. They offer fast response

time and are highly modular. A range of different resolutions and detection heights are available. In addition, the MLG Standard automation light grid offers a wide spectrum of application options and excellent durability.

At a glance

- Up to 3 x PNP or NPN switching outputs
- Resolutions of 10 / 20 / 30 / 50 mm and customer-specific resolutions
- Working range up to 8.5 m
- Detection heights of over 3 m and up to 240 beams possible
- Short response time < 3 ms
- Automatic teach during power on

Your benefits

- Easy-to-see status information helps avoid interrupting operation, saves costs
- Different beam separation options, detection heights and output configurations ensure a reliable solution
- Integrated interfaces reduce cabling time and costs
- A fully modular system guarantees the optimal solution for the customer

→ www.mysick.com/en/MLG_Standard

Detailed technical data

Features

Technology	Sender/receiver
Task	Measurement light grid
Minimum detectable object (MDO)	Parallel beam: 15 mm ... 60 mm Cross beam: 10 mm ... 35 mm
Number of beams	3 ... 240
Configuration	No configuration

Performance

Maximum range ¹⁾	7 m 12 m
Minimum range	Parallel beam: ≥ 0 mm Cross beam: 200 mm (10 mm beam separation) Cross beam: 360 mm (20 mm beam separation) Cross beam: 520 mm (30 mm beam separation) Cross beam: 840 mm (50 mm beam separation)
Response time ²⁾	Parallel beam: 1.5 ms ... 37 ms Cross beam: depending on type

¹⁾ No reserve for environmental issues and deterioration of the diode.

²⁾ With resistive load.

Interfaces

Inputs ¹⁾	1 x PNP 1 x NPN
-----------------------------	--------------------

¹⁾ 1 test input for sender.

Mechanics/electronics

Wave length	IR, 880 nm
Supply voltage V_s	DC 18 V ... 30 V
Power consumption sender ¹⁾	< 140 mA + 2 mA per beam
Power consumption receiver ¹⁾	< 100 mA + 3 mA per beam
Ripple	< 5 V_{ss}
Output current I_{max}	100 mA
Output load capacitive	100 nF
Output load inductive	1 H
Initialization time	1 s
Dimensions (W x H x D)	34 mm x 214 mm x 29 mm ... 34 mm x 3,335 mm x 29 mm
Housing material	Aluminum
Indication	LED, 7-segment display
Synchronization	Cable
Enclosure rating	IP 65
Circuit protection	U_v connections reverse-polarity protected Output Q short-circuit protected Interference suppression
Weight	0.73 kg ... 7.722 kg
Front screen	PMMA

¹⁾ Without load with 24 V.

B

Ambient data

Protection class	III
EMC	EN 60947-5-2
Ambient temperature	Operation: -25 °C ... +55 °C Storage: -40 °C ... +70 °C
Ambient light safety ¹⁾	Direct: 12,500 lx Indirect: 50,000 lx
Vibration resistance	5 g, 10 Hz ... 55 Hz (IEC 68-2-6)
Shock load	10 g / DIN EN 60068-2-29 / 16 ms

¹⁾ Sunlight.

Specific data

Connection type	Evaluation beams	Switching output	Model name	Ordering information
Connector M12, 5-pin	Parallel beam	1 x PNP	MLGx-xxxxF5x1	B-10
		1 x NPN	MLGx-xxxxE5x1	B-11
	Cross beam	1 x PNP	MLGx-xxxxF5x3	B-11

Ordering information

The part numbers below show a selection of our common configurations and represent only a portion of the product portfolio. The type code on page B-12 indicates all possible configurations that can be ordered.

Please note: Sender and receiver are only offered as a pair.

MLGx-xxxxF5x1

- **Connection type:** Connector M12, 5-pin
- **Evaluation beams:** Parallel beam
- **Switching output:** 1 x PNP

Beam separation	Working range	Detection height	Model name	Part no.
10 mm	5 m	140 mm	MLG1-0140F511	1024259
		590 mm	MLG1-0590F511	1025650
		1,040 mm	MLG1-1040F511	1046656
		1,490 mm	MLG1-1490F511	1041802
		1,940 mm	MLG1-1940F511	1041319
		2,090 mm	MLG1-2090F511	1044681
10 mm	8.5 m	140 mm	MLG1-0140F521	1026370
		290 mm	MLG1-0290F521	1024123
20 mm	5 m	140 mm	MLG2-0140F511	1024306
		280 mm	MLG2-0280F511	1023372
		440 mm	MLG2-0440F511	1023560
		580 mm	MLG2-0580F511	1053924
		880 mm	MLG2-0880F511	1041150
		1,180 mm	MLG2-1180F511	1040303
		1,480 mm	MLG2-1480F511	1048172
		2,080 mm	MLG2-2080F511	1044765
		2,380 mm	MLG2-2380F511	1023572

Beam separation	Working range	Detection height	Model name	Part no.	
30 mm	5 m	270 mm	MLG3-0270F511	1023671	
		420 mm	MLG3-0420F511	1022103	
		570 mm	MLG3-0570F511	1049023	
		1,470 mm	MLG3-1470F511	1022102	
		1,920 mm	MLG3-1920F511	1052856	
		2,070 mm	MLG3-2070F511	1053905	
		2,370 mm	MLG3-2370F511	1052857	
		2,670 mm	MLG3-2670F511	1047287	
	8.5 m	120 mm	MLG3-0120F521	1023008	
		870 mm	MLG3-0870F521	1023003	
	50 mm	5 m	250 mm	MLG5-0250F511	1025852
			400 mm	MLG5-0400F511	1023440
			700 mm	MLG5-0700F511	1022867
			1,000 mm	MLG5-1000F511	1023538
1,450 mm			MLG5-1450F511	1023738	
1,900 mm			MLG5-1900F511	1029193	
2,050 mm			MLG5-2050F511	1040125	
2,350 mm			MLG5-2350F511	1040304	
2,650 mm		MLG5-2650F511	1046670		
8.5 m		700 mm	MLG5-0700F521	1025854	
		1,000 mm	MLG5-1000F521	1048022	

B

MLGx-xxxxE5x1

- **Connection type:** Connector M12, 5-pin
- **Evaluation beams:** Parallel beam
- **Switching output:** 1 x NPN

Beam separation	Working range	Detection height	Model name	Part no.
20 mm	5 m	140 mm	MLG2-0140E511	1028564
50 mm	5 m	400 mm	MLG5-0400E511	1023766
		1,450 mm	MLG5-1450E511	1042392

MLGx-xxxxF5x3

- **Connection type:** Connector M12, 5-pin
- **Evaluation beams:** Cross beam
- **Switching output:** 1 x PNP

Beam separation	Working range	Detection height	Model name	Part no.
10 mm	5 m	1,340 mm	MLG1-1340F513	1054844
20 mm	5 m	740 mm	MLG2-0740F513	1022164
30 mm	5 m	2,220 mm	MLG3-2220F513	1022060
50 mm	5 m	1,000 mm	MLG5-1000F513	1022649
	8.5 m	550 mm	MLG5-0550F523	1044284

Type code

B

Beam separation

1	10 mm
2	20 mm
3	30 mm
5	50 mm
7	25 mm ¹⁾

Detection height²⁾

0100	100 mm
...	...
3140	3,140 mm

Interface³⁾

F2	6 x PNP outputs, 2 x PNP inputs
F4	6 x PNP outputs, 2 x PNP inputs
F5	1 x PNP output
F8	3 x PNP outputs, 1 x PNP input
E2	6 x NPN outputs, 2 x NPN inputs
E4	6 x NPN outputs, 2 x NPN inputs
E5	1 x NPN output
E8	3 x NPN outputs, 1 x NPN input
I2	1 x RS-485, 4 x PNP outputs, 2 x PNP inputs
I4	1 x RS-485, 4 x PNP outputs, 2 x PNP inputs
I8	1 x RS-485, 1 x PNP output, 1 x PNP input
T2	1 x RS-485, 4 x NPN outputs, 2 x NPN inputs
T4	1 x RS-485, 4 x NPN outputs, 2 x NPN inputs
T8	1 x RS-485, 1 x NPN output, 1 x NPN input
C8	1 x CANopen, 1 x PNP output, 1 x PNP input
P8	1 x PROFIBUS, 1 x PNP output, 1 x PNP input
A2	2 x analog outputs, 4 x PNP outputs, 2 x PNP inputs
A4	2 x analog outputs, 4 x PNP outputs, 2 x PNP inputs
A8	2 x analog outputs, 1 x PNP output, 1 x PNP input
N2	2 x analog outputs, 4 x NPN outputs, 2 x NPN inputs
N4	2 x analog outputs, 4 x NPN outputs, 2 x NPN inputs
N8	2 x analog outputs, 1 x NPN output, 1 x NPN input

Connection type

2	Terminals
4	M12, 12-pin
5	M12, 5-pin
8	M12, 8-pin

MLG - [] [] [] [] [] Type code continues on the next page

¹⁾ On demand.

²⁾ Max. 240 beams possible.

³⁾ Number refers to possible connection type.

Working range

1	5 m (open angle $\pm 3^\circ$), standard
2	8.5 m (open angle $\pm 3^\circ$), standard
3	20 m (open angle $\pm 10^\circ$) ¹⁾
4	5 m (open angle $\pm 10^\circ$)
5	8.5 m (open angle $\pm 10^\circ$)
6	5 m (open angle $\pm 1.8^\circ$) ¹⁾

Configuration

1	Standard (switching)
2	Configuration interface
3	Cross beam (3-times)
5	Cross beam (5-times) ¹⁾



¹⁾ On demand.

Dimensional drawing

MLGx-xxxxE5x1
MLGx-xxxxF5x1

B

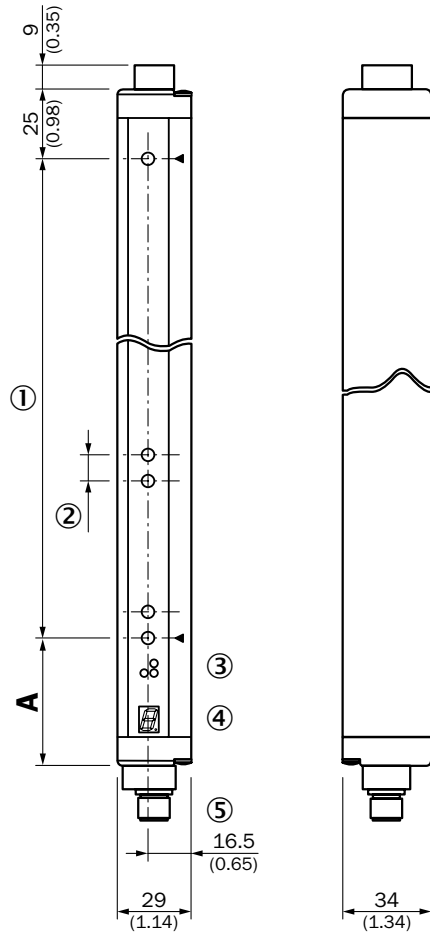

Dimensions in mm (inch)

	A
	Distance: MLG edge - first beam
Beam separation 10 mm	49 (1.93)
Beam separation 20 mm	49 (1.93) ¹⁾ / 59 (2.32) ²⁾
Beam separation 30 mm	69 (2.72)
Beam separation 50 mm	89 (3.50)

¹⁾ With even number of beams.
²⁾ With odd number of beams.

All dimensions in mm (inch)

- ① Detection height (see optical performance)
- ② Beam separation (10, 20, 30, 50 mm)
- ③ Status indicator: LEDs green, yellow, red
- ④ Indicator panel, 7-segment display
- ⑤ Connector M12, 5-pin

MLGx-xxxxE5x3
MLGx-xxxxF5x3

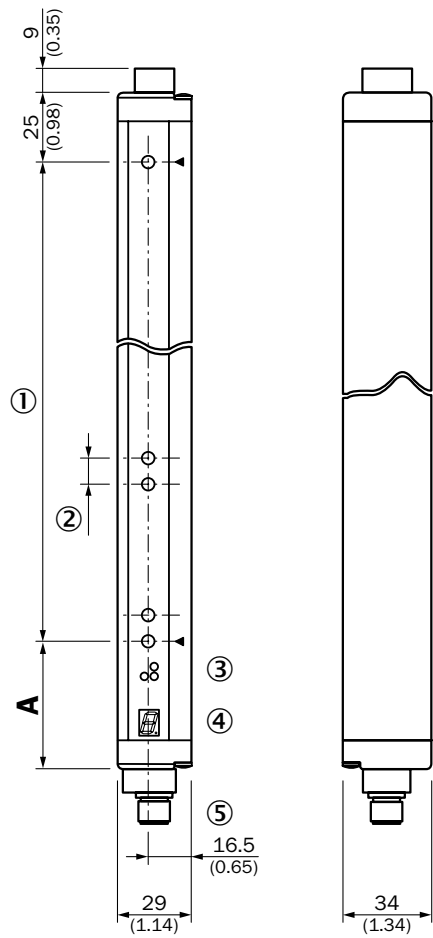

Dimensions in mm (inch)

	A
	Distance: MLG edge – first beam
Beam separation 10 mm	49 (1.93)
Beam separation 20 mm	49 (1.93) ¹⁾ / 59 (2.32) ²⁾
Beam separation 30 mm	69 (2.72)
Beam separation 50 mm	89 (3.50)

¹⁾ With even number of beams.
²⁾ With odd number of beams.

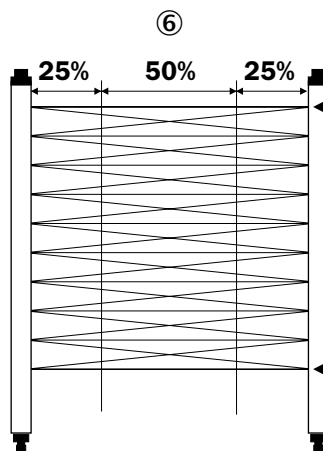

All dimensions in mm (inch)

- ① Detection height (see optical performance)
- ② Beam separation (10, 20, 30, 50 mm)
- ③ Status indicator: LEDs green, yellow, red
- ④ Indicator panel, 7-segment display
- ⑤ Connector M12, 5-pin
- ⑥ Cross beam function

B

Adjustments

LED display receiver

B

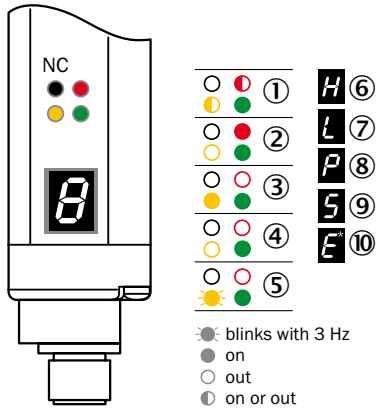

- ① Supply voltage
- ② Device error
- ③ No object in the light path
- ④ Object in the light path
- ⑤ Pollution indication or alignment aid
- ⑥ Blocked Beams Hold (BBH)
- ⑦ Activated teach-in procedure
- ⑧ ParamMode is active
- ⑨ Standby
- ⑩ Error: E1 = sync. error; E2 = less receiver signal; E9 = defect

Connection type and diagram

Sender
Connector
M12, 5-pin

Receiver
Connector
M12, 5-pin

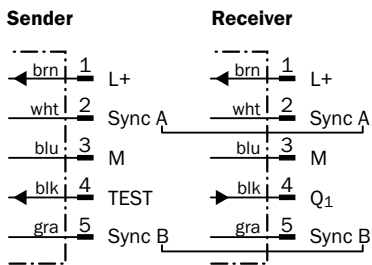
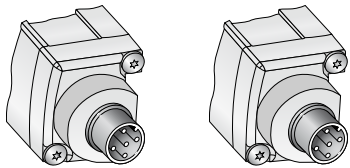

Recommended accessories



Complete accessories for the MLG Standard include: 1 female connector cable, 1 bracket, 1 t-junction and 1 connection cable.

Please take note of the number of pins on the connector when choosing connection cables.



Adapters/distributors (without cable)

	Brief description	Model name	Part no.
	T-junction, 1x plug M12, 5-pin and 2x socket M12, 5-pin	SBO-02G12-SM	6029305

Mounting brackets/plates

	Brief description	Model name	Part no.
	Mounting kit 1, adjustable, swivel mount, for all detection heights in small housings, plastic, without mounting material, 4 pcs	BEF-2SMKEAKU4	2019649
	Mounting kit, side bracket including four sliding nuts for MLG/ELG/HLG, 4 pcs	BEF-NUT-MLG	2023696
	Mounting bracket, steel, zinc coated, without mounting material, 4 pcs	BEF-WK-XLG	2029100

Plug connectors and cables

	Brief description	Model name	Part no.
 Illustration may differ	Female connector, M12, 5-pin, straight, 2 m, PVC	DOL-1205-G02M	6008899
	Female connector, M12, 5-pin, straight, 5 m, PVC	DOL-1205-G05M	6009868
	Female connector, M12, 5-pin, straight, 10 m, PVC	DOL-1205-G10M	6010544
	Female connector, M12, 5-pin, straight, 15 m, PVC	DOL-1205-G15M	6029215
 Illustration may differ	Female connector, M12, 5-pin, angled, 2 m, PVC	DOL-1205-W02M	6008900
	Female connector, M12, 5-pin, angled, 5 m, PVC	DOL-1205-W05M	6009869
	Female connector, M12, 5-pin, angled, 10 m, PVC	DOL-1205-W10M	6010542
	Connection cable, M12, 5-pin, plug straight/socket straight, 5 m, PUR halogen free	DSL-1205-G05MC	6029282
	Connection cable, M12, 5-pin, plug straight/socket straight, 10 m, PUR halogen free	DSL-1205-G10MC	6038954

For additional accessories including dimensional drawings, please see page E-2.

Special functions

Modular construction

The advanced automation light grids are using a modular design principle. Every optics module has 15 beams. If you want to calculate the detection height, you have to subtract the single beam separation of the overall height of the optics modules.

E.g. $3 \times 150 \text{ mm} = 450 \text{ mm}$ (overall height)
 $450 \text{ mm} - 10 \text{ mm}$ (beam separation) = 440 mm (detection height)

Detection height

Minimum = 100 mm
 Maximum = 3,140 mm

Beam separation

Minimum = 10 mm
 Maximum = 50 mm

B

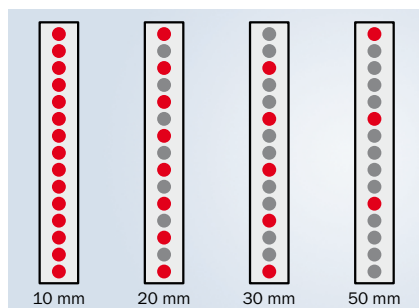
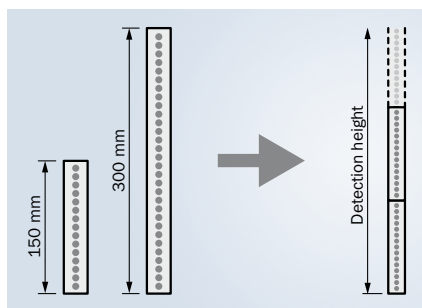

Simple interconnection of optics modules with lengths of 150 mm or 300 mm. Monitoring height determines how many modules to use.

Beam separation varies depending on how the optics modules are equipped with LEDs. The smaller the beam separation, the higher the resolution will be. There is also an MLG variant with a beam separation of 25 mm.

Plug & Play

1. Plug in and tighten the ring of the connector

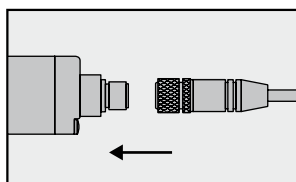

2. Device is ready for use

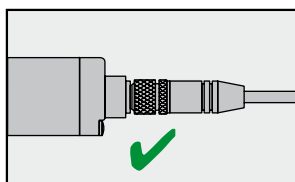

B

For customized solutions



B



Additional information

Detailed technical data. B-21
 Ordering information. B-22
 Dimensional drawing B-27
 Adjustments B-28
 Connection type and diagram . . . B-28
 Recommended accessories. B-29
 Special functions. B-31

Product description

The programmable version of the MLG automation light grid is ideal for measurement applications, such as variable height measurement or for classifying objects. The programmable models include easy-to-use software, which enables extreme flexibility. The software quickly and easily turns a standard sensor into a custom problem solver,

reducing the number of sensors, PLCs and programming required. The MLG offers many different configuration options and interfaces. It provides a choice of different detection heights and beam separation. The MLG can be supplied pre-programmed by SICK. For optimum installation, the customer can choose between different mounting brackets.

At a glance

- Resolutions of 10 / 20 / 30 / 50 mm and customer-specific resolutions
- Working range up to 8.5 m
- Detection heights of over 3 m and up to 240 beams possible
- Short response time < 3 ms
- External teach-in for optimal sensitivity settings
- Easy-to-use setup software for customized application

Your benefits

- Intelligent evaluation software saves costs by quickly and easily turning a standard sensor into a custom problem solver, reducing the number of sensors, PLCs and programming required
- Easy-to-see status information helps avoid interrupting operation
- Different beam separation options, detection heights and output configurations ensure a reliable solution
- 6 discrete outputs for custom solutions
- Robust metal housing stands up to tough environments and reduces downtime

→ www.mysick.com/en/MLG_Programmable

Detailed technical data

Features

Technology	Sender/receiver
Task	Measurement light grid
Minimum detectable object (MDO)	Parallel beam: 15 mm ... 60 mm
Number of beams	3 ... 240
Configuration	Configuration interface (measuring)

Performance

Maximum range ¹⁾	7 m 12 m
Minimum range	Parallel beam: ≥ 0 mm
Response time ²⁾	Parallel beam: 1.5 ms ... 37 ms Cross beam: depending on type

¹⁾ No reserve for environmental issues and deterioration of the diode.

²⁾ With resistive load.

Interfaces

Inputs	2 x PNP 2 x NPN
--------	--------------------

Mechanics/electronics

Wave length	IR, 880 nm
Supply voltage V_s	DC 18 V ... 30 V
Power consumption sender ¹⁾	< 140 mA + 2 mA per beam
Power consumption receiver ¹⁾	< 100 mA + 3 mA per beam
Ripple	< 5 V_{ss}
Output current I_{max}	100 mA
Output load capacitive	100 nF
Output load inductive	1 H
Initialization time	1 s
Dimensions (W x H x D)	34 mm x 214 mm x 29 mm ... 34 mm x 3,335 mm x 29 mm
Housing material	Aluminum
Indication	LED, 7-segment display
Synchronization	Cable
Enclosure rating	IP 65
Circuit protection	V_s connections reverse-polarity protected Output Q short-circuit protected Interference suppression
Weight	0.73 kg ... 7.722 kg
Front screen	PMMA

¹⁾ Without load with 24 V.

Ambient data

Protection class	III
EMC	EN 60947-5-2
Ambient temperature	Operation: -25 °C ... +55 °C Storage: -40 °C ... +70 °C
Ambient light safety ¹⁾	Direct: 12,500 lx Indirect: 50,000 lx
Vibration resistance	5 g, 10 Hz ... 55 Hz (IEC 68-2-6)
Shock load	10 g / DIN EN 60068-2-29 / 16 ms

¹⁾ Sunlight.

Specific data

Connection type	Switching output	Model name	Ordering information
Terminals	4 x PNP (RS-485)	MLGx-xxxxI2x2	B-22
Connector M12, 8-pin	1 x PNP (RS-485)	MLGx-xxxxI8x2	B-23
	3 x PNP	MLGx-xxxxF8x2	B-24
	1 x NPN (RS-485)	MLGx-xxxxT8x2	B-24
Connector M12, 12-pin	1 x PNP (RS-485)	MLGx-xxxxI4x2	B-24

Ordering information

The part numbers below show a selection of our common configurations and represent only a portion of the product portfolio. The type code on page B-25 indicates all possible configurations that can be ordered.

Please note: Sender and receiver are only offered as a pair.

MLGx-xxxxI2x2

- **Connection type:** Terminals
- **Switching output:** 4 x PNP (RS-485)

Beam separation	Working range	Detection height	Model name	Part no.
10 mm	5 m	140 mm	MLG1-0140I212	1026223
		290 mm	MLG1-0290I212	1027041
		440 mm	MLG1-0440I212	1040662
		590 mm	MLG1-0590I212	1023979
		1,640 mm	MLG1-1640I212	1043588
		2,390 mm	MLG1-2390I212	1025980
20 mm	5 m	440 mm	MLG2-0440I212	1023595
		740 mm	MLG2-0740I212	1023596
		1,180 mm	MLG2-1180I212	1047867
		2,680 mm	MLG2-2680I212	1043589
		3,140 mm	MLG2-3140I212	1022096
50 mm	5 m	1,000 mm	MLG5-1000I212	1023614
		1,450 mm	MLG5-1450I212	1023615

MLGx-xxxxl8x2

- **Connection type:** Connector M12, 8-pin
- **Switching output:** 1 x PNP (RS-485)

Beam separation	Working range	Detection height	Model name	Part no.
10 mm	5 m	140 mm	MLG1-0140l812	1022573
		290 mm	MLG1-0290l812	1025943
		440 mm	MLG1-0440l812	1024038
		590 mm	MLG1-0590l812	1022167
		740 mm	MLG1-0740l812	1023558
		1,040 mm	MLG1-1040l812	1045148
		1,190 mm	MLG1-1190l812	1042916
		1,340 mm	MLG1-1340l812	1022712
		1,640 mm	MLG1-1640l812	1024294
		2,090 mm	MLG1-2090l812	1048009
		2,240 mm	MLG1-2240l812	1052384
	2,390 mm	MLG1-2390l812	1023839	
	8.5 m	290 mm	MLG1-0290l822	1022572
		590 mm	MLG1-0590l822	1023872
740 mm		MLG1-0740l822	1048755	
2,390 mm		MLG1-2390l822	1025817	
20 mm	5 m	280 mm	MLG2-0280l812	1023589
		440 mm	MLG2-0440l812	1051735
		740 mm	MLG2-0740l812	1022855
		1,340 mm	MLG2-1340l812	1029182
		1,640 mm	MLG2-1640l812	1042917
		1,780 mm	MLG2-1780l812	1041246
		1,940 mm	MLG2-1940l812	1023559
		2,080 mm	MLG2-2080l812	1026495
		2,540 mm	MLG2-2540l812	1024248
30 mm	5 m	720 mm	MLG3-0720l812	1025635
		1,020 mm	MLG3-1020l812	1054091
		1,470 mm	MLG3-1470l812	1023642
		1,620 mm	MLG3-1620l812	1029481
		1,920 mm	MLG3-1920l812	1023392
		2,070 mm	MLG3-2070l812	1026548
		2,820 mm	MLG3-2820l812	1048056
	3,120 mm	MLG3-3120l812	1024071	
	8.5 m	2,820 mm	MLG3-2820l822	1052252

B

Beam separation	Working range	Detection height	Model name	Part no.
50 mm	5 m	250 mm	MLG5-0250I812	1023607
		700 mm	MLG5-0700I812	1041254
		850 mm	MLG5-0850I812	1024058
		1,000 mm	MLG5-1000I812	1044580
		1,450 mm	MLG5-1450I812	1023608
		1,600 mm	MLG5-1600I812	1026294
		2,050 mm	MLG5-2050I812	1048925
		2,200 mm	MLG5-2200I812	1042783
		2,500 mm	MLG5-2500I812	1042785
		2,650 mm	MLG5-2650I812	1043992
		3,100 mm	MLG5-3100I812	1040305

B

MLGx-xxxxF8x2

- **Connection type:** Connector M12, 8-pin
- **Switching output:** 3 x PNP

Beam separation	Working range	Detection height	Model name	Part no.
10 mm	8.5 m	440 mm	MLG1-0440F822	1052400
		590 mm	MLG1-0590F822	1028441
20 mm	8.5 m	280 mm	MLG2-0280F822	1054391
		1,180 mm	MLG2-1180F822	1041768
		3,140 mm	MLG2-3140F822	1048438
30 mm	8.5 m	270 mm	MLG3-0270F822	1044511
		570 mm	MLG3-0570F822	1044643
		2,220 mm	MLG3-2220F822	1041610
		3,120 mm	MLG3-3120F822	1025597
50 mm	8.5 m	2,350 mm	MLG5-2350F822	1025461

MLGx-xxxxT8x2

- **Connection type:** Connector M12, 8-pin
- **Switching output:** 1 x NPN (RS-485)

Beam separation	Working range	Detection height	Model name	Part no.
10 mm	5 m	2,090 mm	MLG1-2090T812	1026417

MLGx-xxxxI4x2

- **Connection type:** Connector M12, 12-pin
- **Switching output:** 1 x PNP (RS-485)

Beam separation	Working range	Detection height	Model name	Part no.
20 mm	8.5 m	280 mm	MLG2-0280I422	1055277

Type code

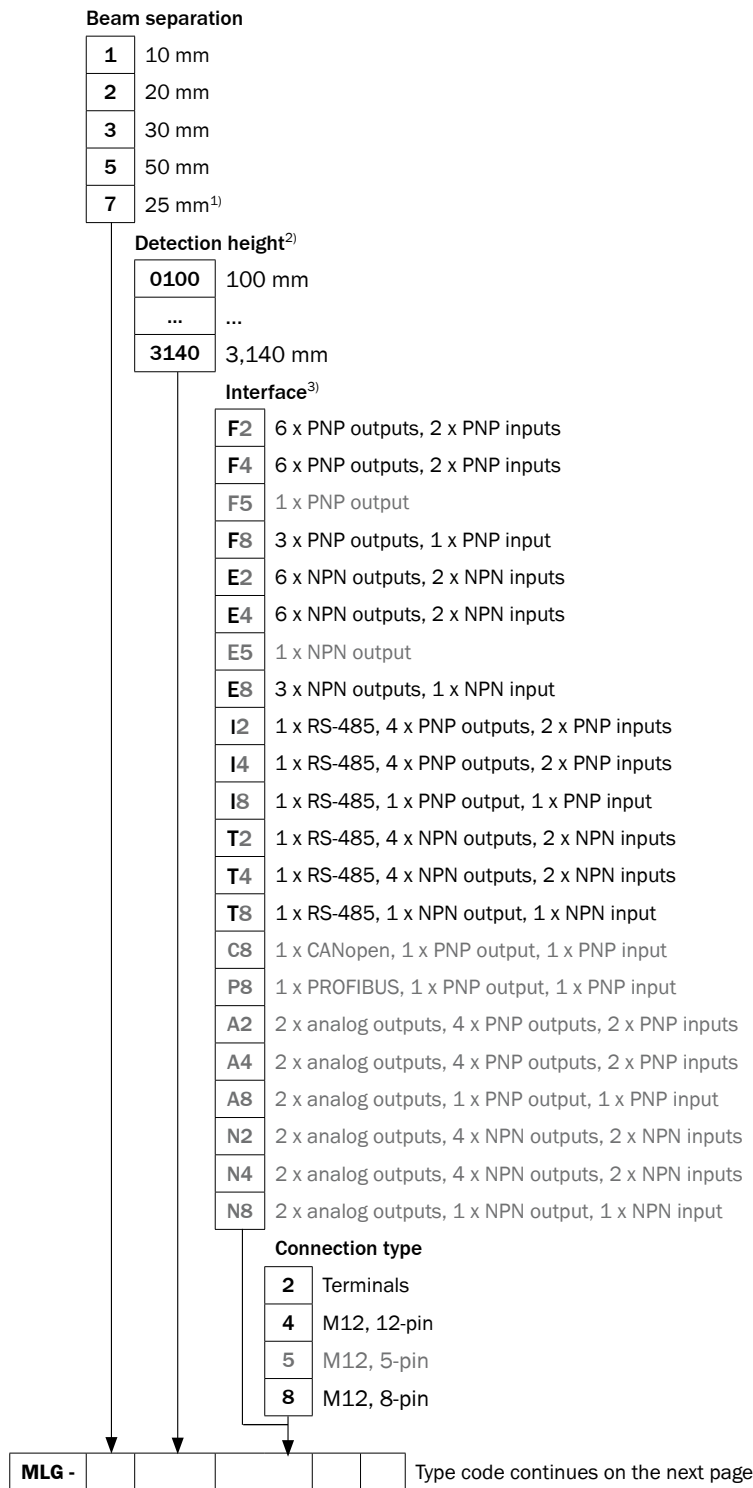

B

¹⁾ On demand.

²⁾ Max. 240 beams possible.

³⁾ Number refers to possible connection type.

B

Working range

1	5 m (open angle $\pm 3^\circ$), standard
2	8.5 m (open angle $\pm 3^\circ$), standard
3	20 m (open angle $\pm 10^\circ$) ¹⁾
4	5 m (open angle $\pm 10^\circ$)
5	8.5 m (open angle $\pm 10^\circ$)
6	5 m (open angle $\pm 1.8^\circ$) ¹⁾

Configuration

1	Standard (switching)
2	Configuration interface
3	Cross beam (3-times)
5	Cross beam (5-times) ¹⁾



¹⁾ On demand.

Dimensional drawing

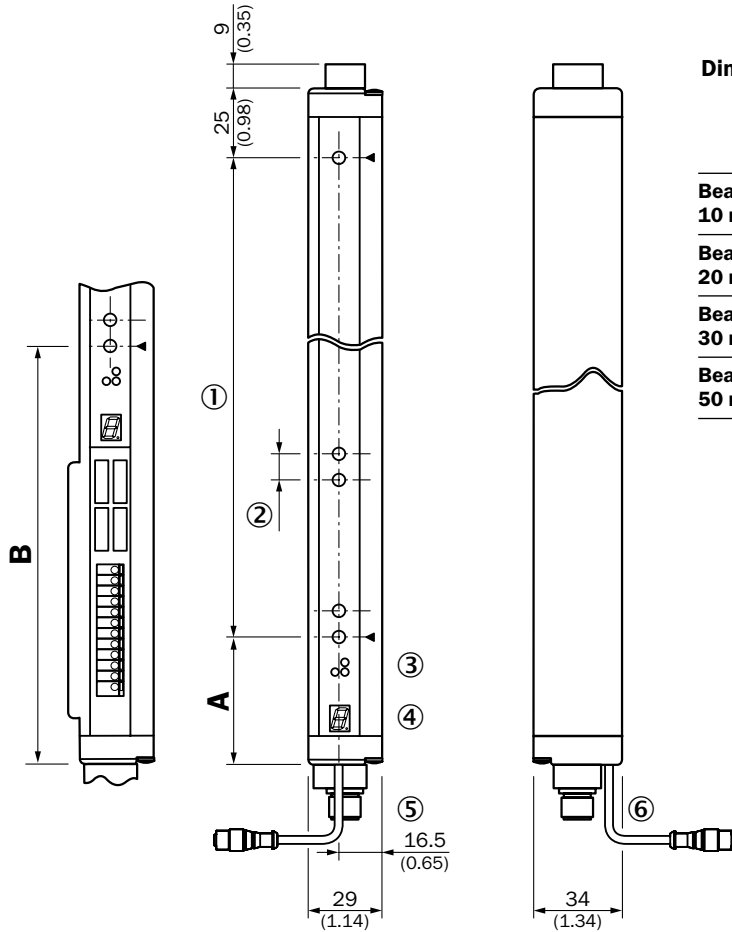

Dimensions in mm (inch)

	A	B
	Distance: MLG edge - first beam	
Beam separation MLG1		
10 mm	49 (1.93)	160 (6.30)
Beam separation MLG2		
20 mm	49 (1.93) ¹⁾	170 (6.69)
	59 (2.32) ²⁾	
Beam separation MLG3		
30 mm	69 (2.72)	180 (7.09)
Beam separation MLG5		
50 mm	89 (3.50)	200 (7.87)

¹⁾ With even number of beams.
²⁾ With odd number of beams.

All dimensions in mm (inch)

- ① Detection height (see optical performance)
- ② Beam separation (10, 20, 30, 50 mm)
- ③ Status indicator: LEDs green, yellow, red
- ④ Indicator panel, 7-segment display
- ⑤ Terminals: M16 cable entry/connector M12, 12-pin
- ⑥ Configuration connector M8, 4-pin

B

Adjustments

LED display receiver

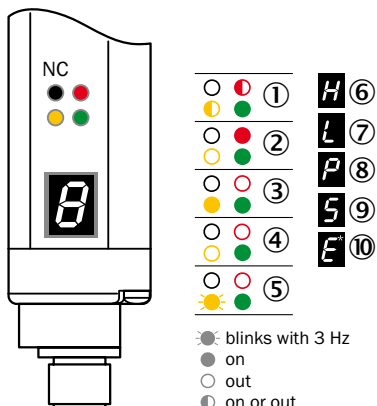

B

- ① Supply voltage
- ② Device error
- ③ No object in the light path
- ④ Object in the light path
- ⑤ Pollution indication or alignment aid
- ⑥ Blocked Beams Hold (BBH)
- ⑦ Activated teach-in procedure
- ⑧ ParamMode is active
- ⑨ Standby
- ⑩ Error: E1 = sync. error; E2 = less receiver signal; E9 = defect

Connection type and diagram

MLGx-xxxxx2xx
Sender
Terminals

MLGx-xxxxx2xx
Receiver
Terminals

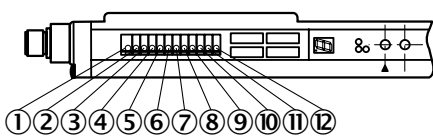
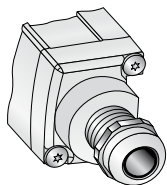

Sender

Receiver

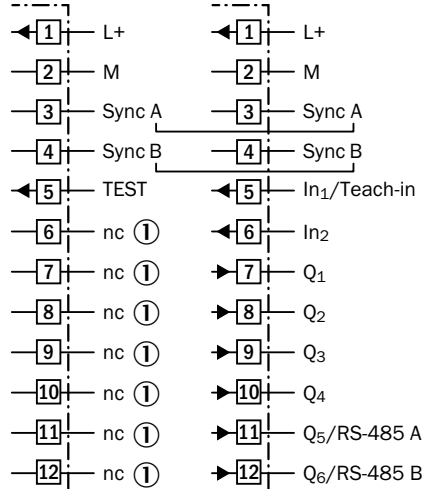

① Not connected

MLGx-xxxxx8xx
Sender
Connector
M12, 8-pin

MLGx-xxxxx8xx
Receiver
Connector
M12, 8-pin

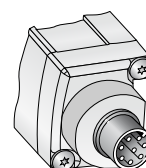
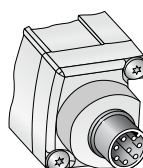

Sender

Receiver

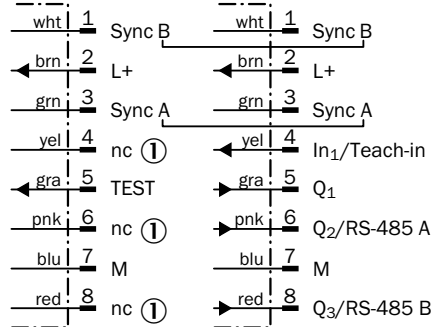

① Not connected

MLGx-xxxxx4xx
Sender
Connector
M12, 5-pin

MLGx-xxxxx4xx
Receiver
Connector
M12, 12-pin

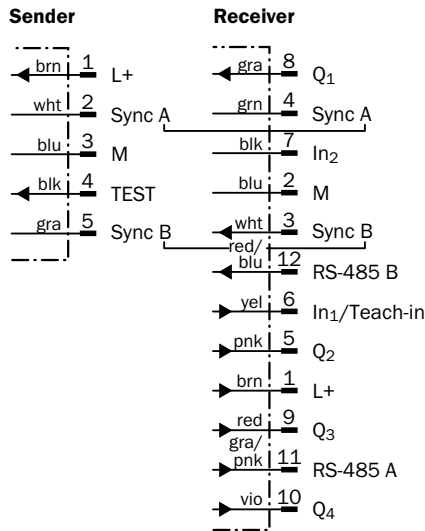
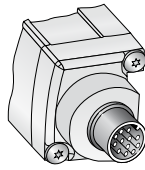
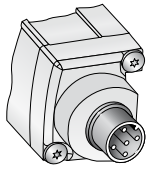

B



Recommended accessories

Complete accessories for the MLG Programmable include: 1 female connector, 1 bracket, 1 t-junction, 1 connection cable and 1 configuration cable. Please take note of the number of pins on the connector when choosing connection cables.







Adapters/distributors (without cable)

	Brief description	Model name	Part no.
	T-junction, 1x plug M12, 8-pin and 2x socket M12, 8-pin	SBO-02F12-SM	6029306

Mounting brackets/plates

	Brief description	Model name	Part no.
	Mounting kit 1, adjustable, swivel mount, for all detection heights in small housings, plastic, without mounting material, 4 pcs	BEF-2SMKEAKU4	2019649
	Mounting kit, side bracket including four sliding nuts for MLG/ELG/HLG, 4 pcs	BEF-NUT-MLG	2023696
	Mounting bracket, steel, zinc coated, without mounting material, 4 pcs	BEF-WK-XLG	2029100

Plug connectors and cables

	Brief description	Model name	Part no.
 Illustration may differ	Female connector, M12, 5-pin, straight, 2 m, PVC	DOL-1205-G02M	6008899
	Female connector, M12, 5-pin, straight, 5 m, PVC	DOL-1205-G05M	6009868
	Female connector, M12, 5-pin, straight, 10 m, PVC	DOL-1205-G10M	6010544
	Female connector, M12, 5-pin, straight, 15 m, PVC	DOL-1205-G15M	6029215
 Illustration may differ	Female connector, M12, 5-pin, angled, 2 m, PVC	DOL-1205-W02M	6008900
	Female connector, M12, 5-pin, angled, 5 m, PVC	DOL-1205-W05M	6009869
	Female connector, M12, 5-pin, angled, 10 m, PVC	DOL-1205-W10M	6010542
 Illustration may differ	Female connector, M12, 8-pin, straight, 2 m, PVC, shielded	DOL-1208-G02MA	6020633
	Female connector, M12, 8-pin, straight, 5 m, PVC, shielded	DOL-1208-G05MA	6020993
	Female connector, M12, 8-pin, straight, 10 m, PVC, shielded	DOL-1208-G10MA	6022152
 Illustration may differ	Female connector, M12, 8-pin, angled, 2 m, PVC, shielded	DOL-1208-W02MA	6020992
	Female connector, M12, 8-pin, angled, 5 m, PVC, shielded	DOL-1208-W05MA	6021033
 Illustration may differ	Female connector, M12, 12-pin, straight, 2 m, PVC, shielded	DOL-1212-G02MA	6034604
	Female connector, M12, 12-pin, straight, 5 m, PVC, shielded	DOL-1212-G05MA	6034605
	Female connector, M12, 12-pin, straight, 10 m, PVC, shielded	DOL-1212-G10MAS01	6037356
 Illustration may differ	Configuration cable, 2 m, PVC	DSL-8D04-G02M	2023695
	Connection cable, M12, 8-pin, plug straight/socket straight, 2 m, PUR halogen free, shielded	DSL-1208-G02MAC	6030121
	Connection cable, M12, 8-pin, plug straight/socket straight, 5 m, PUR halogen free, shielded	DSL-1208-G05MAC	6032325
	Connection cable, M12, 8-pin, plug straight/socket straight, 10 m, PUR halogen free, shielded	DSL-1208-G10MAC	6034901

For additional accessories including dimensional drawings, please see page E-2.

Special functions

Modular construction

The advanced automation light grids are using a modular design principle. Every optics module has 15 beams. If you want to calculate the detection height, you have to subtract the single beam separation of the overall height of the optics modules.

E.g. $3 \times 150 \text{ mm} = 450 \text{ mm}$ (overall height)

$450 \text{ mm} - 10 \text{ mm}$ (beam separation) = 440 mm (detection height)

Detection height

Minimum = 100 mm

Maximum = 3,140 mm

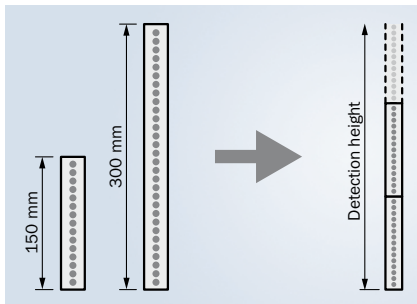

Simple interconnection of optics modules with lengths of 150 mm or 300 mm. Monitoring height determines how many modules to use.

Beam separation

Minimum = 10 mm

Maximum = 50 mm

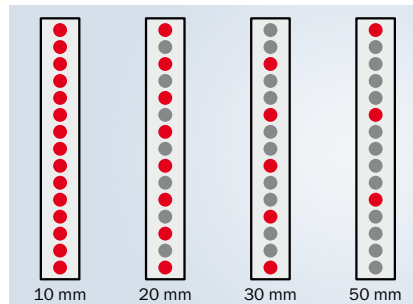

Beam separation varies depending on how the optics modules are equipped with LEDs. The smaller the beam separation, the higher the resolution will be. There is also an MLG variant with a beam separation of 25 mm.

B

For easy integration

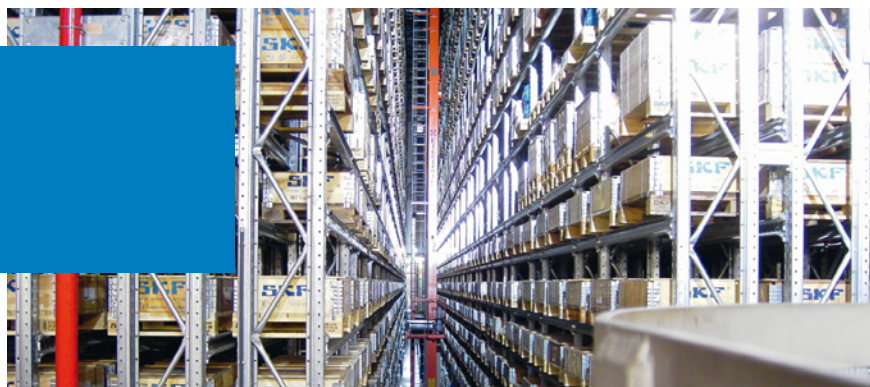

B



Product description

The MLG PROFIBUS version is used for measurement applications and has an integrated PROFIBUS interface. It is ideal for applications, such as variable height measurement or for classifying objects. It includes easy-to-use software, which enables extreme flexibility. The software quickly and easily turns a standard sensor into a custom problem solver, reducing the number of sensors, PLCs and programming required. The MLG PROFIBUS offers many different configura-

tion options and interfaces. It provides a choice of different detection heights and beam separation. It can be supplied pre-programmed by SICK. It has its own PROFIBUS User Organization (PNO) number and the corresponding GSD file that makes it possible for the PLC to interpret the data output of the sensor. For optimum installation, the customer can choose between different mounting brackets.

At a glance

- Integrated PROFIBUS interface
- Resolutions of 10 / 20 / 30 / 50 mm and customer-specific resolutions
- Working range up to 8.5 m
- Detection heights of over 3 m and up to 240 beams possible
- Short response time < 9 ms
- External teach-in for optimal sensitivity settings

Your benefits

- Integrated PROFIBUS User Organization (PNO) number and GSD file for easy connection to a PLC
- Low cabling requirement reduces installation costs
- Easy-to-see light grid status information via the bus system helps avoid interrupting operation
- Different beam separation options, detection heights and output configurations ensure a reliable solution



Additional information

Detailed technical data B-33

Ordering information B-34

Dimensional drawing B-39

Adjustments B-39

Connection type and diagram . . . B-40

Recommended accessories B-41

Special functions B-42

→ www.mysick.com/en/MLG_PROFIBUS

Detailed technical data

Features

Technology	Sender/receiver
Task	Measurement light grid
Minimum detectable object (MDO)	Parallel beam: 15 mm ... 60 mm
Number of beams	3 ... 240
Configuration	GSD file

Performance

Maximum range ¹⁾	7 m 12 m
Minimum range	Parallel beam: ≥ 0 mm
Response time ²⁾	Parallel beam: 9 ms ... 57 ms Cross beam: depending on type

¹⁾ No reserve for environmental issues and deterioration of the diode.

²⁾ With resistive load.

Interfaces

Inputs ¹⁾	1 x PNP
----------------------	---------

¹⁾ 1 x test input for sender.

Mechanics/electronics

Wave length	IR, 880 nm
Supply voltage V_s	DC 18 V ... 30 V
Power consumption sender ¹⁾	< 140 mA + 2 mA per beam
Power consumption receiver ¹⁾	< 100 mA + 3 mA per beam
Ripple	< 5 V_{SS}
Output current I_{max}	100 mA
Output load capacitive	100 nF
Output load inductive	1 H
Initialization time	1 s
Dimensions (W x H x D)	34 mm x 214 mm x 29 mm ... 34 mm x 3,335 mm x 29 mm
Housing material	Aluminum
Indication	LED, 7-segment display
Synchronization	Cable
Enclosure rating	IP 65
Circuit protection	V_s connections reverse-polarity protected Output Q short-circuit protected Interference suppression
Weight	0.73 kg ... 7.722 kg
Front screen	PMMA

¹⁾ Without load with 24 V.

Ambient data

Protection class	III
EMC	EN 60947-5-2
Ambient temperature	Operation: -25 °C ... +55 °C Storage: -40 °C ... +70 °C
Ambient light safety ¹⁾	Direct: 12,500 lx Indirect: 50,000 lx
Vibration resistance	5 g, 10 Hz ... 55 Hz (IEC 68-2-6)
Shock load	10 g / DIN EN 60068-2-29 / 16 ms

¹⁾ Sunlight.

Specific data

Working range	Switching output ¹⁾	Connection type ²⁾	Beam separation	Model name	Ordering information
5 m	1 x PNP	Connector M12, 8-pin	10 mm	MLG1-xxxxP811	B-34
			20 mm	MLG2-xxxxP811	B-35
			30 mm	MLG3-xxxxP811	B-35
			50 mm	MLG5-xxxxP811	B-36

¹⁾ Switching output with adapter not usable.

²⁾ With adapter M12, 5-pin.

Ordering information

The part numbers below show a selection of our common configurations and represent only a portion of the product portfolio. The type code on page B-37 indicates all possible configurations that can be ordered.

Please note: Sender and receiver are only offered as a pair.

MLG1-xxxxP811

- **Working range:** 5 m
- **Switching output:** 1 x PNP (switching output with adapter not usable)
- **Connection type:** Connector M12, 8-pin (with adapter M12, 5-pin)
- **Beam separation:** 10 mm

Detection height	Model name	Part no.
140 mm	MLG1-0140P811	1027723
290 mm	MLG1-0290P811	1028533
440 mm	MLG1-0440P811	1040414
740 mm	MLG1-0740P811	1028847
890 mm	MLG1-0890P811	1042360
1,040 mm	MLG1-1040P811	1040606
1,340 mm	MLG1-1340P811	1029194
1,790 mm	MLG1-1790P811	1029195
2,090 mm	MLG1-2090P811	1029629
2,240 mm	MLG1-2240P811	1028536
2,390 mm	MLG1-2390P811	1028534

MLG2-xxxxP811

- **Working range:** 5 m
- **Switching output:** 1 x PNP (switching output with adapter not usable)
- **Connection type:** Connector M12, 8-pin (with adapter M12, 5-pin)
- **Beam separation:** 20 mm

Detection height	Model name	Part no.
280 mm	MLG2-0280P811	1029525
580 mm	MLG2-0580P811	1028848
740 mm	MLG2-0740P811	1029958
1,040 mm	MLG2-1040P811	1029526
1,180 mm	MLG2-1180P811	1041526
1,480 mm	MLG2-1480P811	1042647
1,940 mm	MLG2-1940P811	1040090
2,080 mm	MLG2-2080P811	1054574
2,380 mm	MLG2-2380P811	1029971
3,140 mm	MLG2-3140P811	1040605

MLG3-xxxxP811

- **Working range:** 5 m
- **Switching output:** 1 x PNP (switching output with adapter not usable)
- **Connection type:** Connector M12, 8-pin (with adapter M12, 5-pin)
- **Beam separation:** 30 mm

Detection height	Model name	Part no.
570 mm	MLG3-0570P811	1046625
720 mm	MLG3-0720P811	1040611
1,020 mm	MLG3-1020P811	1029059
1,170 mm	MLG3-1170P811	1029986
1,470 mm	MLG3-1470P811	1042974
1,620 mm	MLG3-1620P811	1029554
2,070 mm	MLG3-2070P811	1029168
2,220 mm	MLG3-2220P811	1040666
3,120 mm	MLG3-3120P811	1045245

B

MLG5-xxxxP811

- **Working range:** 5 m
- **Switching output:** 1 x PNP (switching output with adapter not usable)
- **Connection type:** Connector M12, 8-pin (with adapter M12, 5-pin)
- **Beam separation:** 50 mm

Detection height	Model name	Part no.
250 mm	MLG5-0250P811	1054398
400 mm	MLG5-0400P811	1029867
700 mm	MLG5-0700P811	1028535
850 mm	MLG5-0850P811	1028478
1,150 mm	MLG5-1150P811	1028845
1,300 mm	MLG5-1300P811	1029473
1,750 mm	MLG5-1750P811	1044972
1,900 mm	MLG5-1900P811	1029456
2,050 mm	MLG5-2050P811	1028739
2,200 mm	MLG5-2200P811	1043531
2,500 mm	MLG5-2500P811	1047117
2,800 mm	MLG5-2800P811	1028844

B

Type code

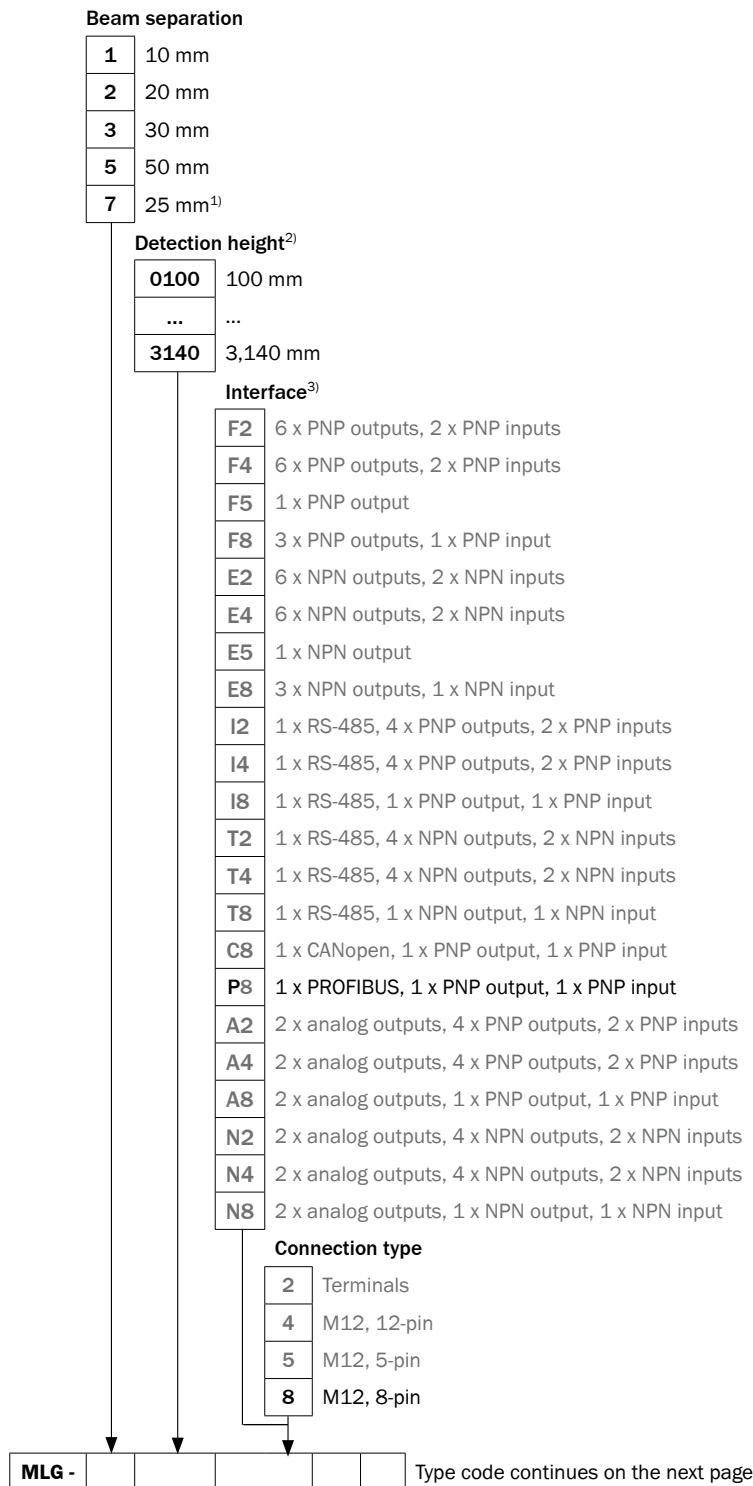

B

¹⁾ On demand.

²⁾ Max. 240 beams possible.

³⁾ Number refers to possible connection type.

B

Working range

1	5 m (open angle $\pm 3^\circ$), standard
2	8.5 m (open angle $\pm 3^\circ$), standard
3	20 m (open angle $\pm 10^\circ$) ¹⁾
4	5 m (open angle $\pm 10^\circ$)
5	8.5 m (open angle $\pm 10^\circ$)
6	5 m (open angle $\pm 1.8^\circ$) ¹⁾

Configuration

1	Standard (switching)
2	Configuration interface
3	Cross beam (3-times)
5	Cross beam (5-times) ¹⁾



¹⁾ On demand.

Dimensional drawing

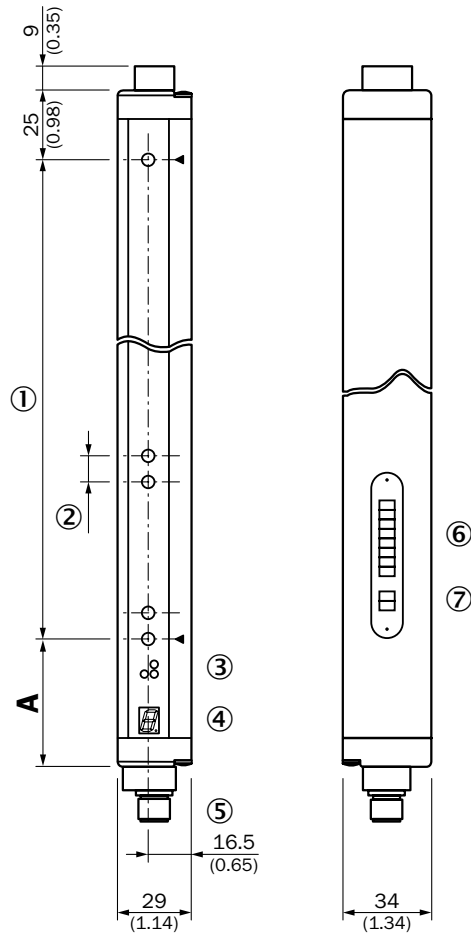

Dimensions in mm (inch)

	A
	Distance: MLG edge – first beam
Beam separation 10 mm	49 (1.93)
Beam separation 20 mm	49 (1.93) ¹⁾ / 59 (2.32) ²⁾
Beam separation 30 mm	69 (2.72)
Beam separation 50 mm	89 (3.50)

- ¹⁾ With even number of beams.
- ²⁾ With odd number of beams.

All dimensions in mm (inch)

- ① Detection height (see optical performance)
- ② Beam spacing (10, 20, 30, 50 mm)
- ③ Status indicator: LEDs green, yellow, red
- ④ Indicator panel, 7-segment display
- ⑤ Connector M12, 8-pin
- ⑥ Address setting
- ⑦ Bus termination

Adjustments

DIP switches

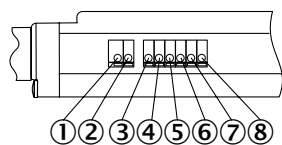

- ① Bus termination
- ② Bus termination
- ③ Address setting
- ④ Address setting
- ⑤ Address setting
- ⑥ Address setting
- ⑦ Address setting
- ⑧ Address setting

LED display receiver

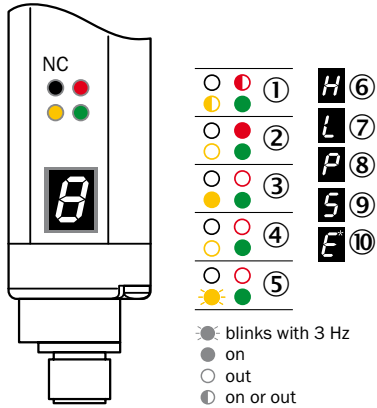

B

- ① Supply voltage
- ② Device error
- ③ No object in the light path
- ④ Object in the light path
- ⑤ Pollution indication or alignment aid
- ⑥ Blocked Beams Hold (BBH)
- ⑦ Activated teach-in procedure
- ⑧ ParamMode is active
- ⑨ Standby
- ⑩ Error: E1 = sync. error; E2 = less receiver signal; E9 = defect

Connection type and diagram

**Sender
Connector
M12, 5-pin**

**Receiver
Connector
M12, 8-pin**

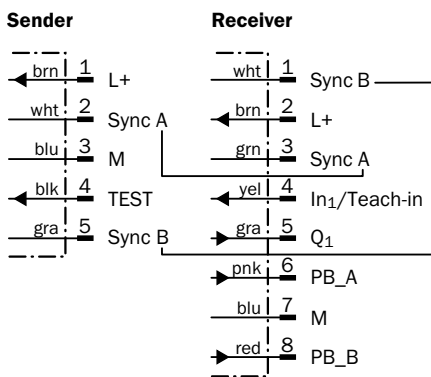
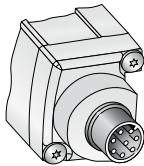
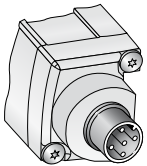



Recommended accessories

Complete accessories for the MLG PROFIBUS include: 1 female connector, 1 PROFIBUS cable, 1 bracket, 1 t-junction, 1 connection cable and 1 adapter.



Please take note of the number of pins on the connector when choosing connection cables.

Adapters/distributors (without cable)





	Brief description	Model name	Part no.
	PROFIBUS adapter, straight	ADAPT-PB-GE-MLG	1027921
	PROFIBUS adapter, angled	ADAPT-PB-WI-MLG	1027901
	T-junction, 1x plug M12, 5-pin and 2x socket M12, 5-pin	SBO-02G12-SM	6029305

B

Mounting brackets/plates

	Brief description	Model name	Part no.
	Mounting kit 1, adjustable, swivel mount, for all detection heights in small housings, plastic, without mounting material, 4 pcs	BEF-2SMKEAKU4	2019649
	Mounting kit, side bracket including four sliding nuts for MLG/ELG/HLG, 4 pcs	BEF-NUT-MLG	2023696

Plug connectors and cables

	Brief description	Model name	Part no.
 Illustration may differ	Female connector, M12, 5-pin, straight, 2 m, PVC	DOL-1205-G02M	6008899
	Female connector, M12, 5-pin, straight, 5 m, PVC	DOL-1205-G05M	6009868
	Female connector, M12, 5-pin, straight, 10 m, PVC	DOL-1205-G10M	6010544
	Female connector, M12, 5-pin, straight, 15 m, PVC	DOL-1205-G15M	6029215
	Female connector, M12, 5-pin, straight, 5 m, PROFIBUS	DOL-1205-G05MQ	6026006
	Female connector, M12, 5-pin, straight, 10 m, PROFIBUS	DOL-1205-G10MQ	6026008
 Illustration may differ	Female connector, M12, 5-pin, angled, 2 m, PVC	DOL-1205-W02M	6008900
	Female connector, M12, 5-pin, angled, 5 m, PVC	DOL-1205-W05M	6009869
	Female connector, M12, 5-pin, angled, 10 m, PVC	DOL-1205-W10M	6010542
	Connection cable, M12, 5-pin, plug straight/socket straight, 5 m, PUR halogen free	DSL-1205-G05MC	6029282
	Connection cable, M12, 5-pin, plug straight/socket straight, 10 m, PUR halogen free	DSL-1205-G10MC	6038954
	Male connector, M12, 5-pin, straight, 5 m, PROFIBUS	STL-1205-G05MQ	6026005
	Male connector, M12, 5-pin, straight, 10 m, PROFIBUS	STL-1205-G10MQ	6026007

For additional accessories including dimensional drawings, please see page E-2.

Special functions

Modular construction

The advanced automation light grids are using a modular design principle. Every optics module has 15 beams. If you want to calculate the detection height, you have to subtract the single beam separation of the overall height of the optics modules.

E.g. $3 \times 150 \text{ mm} = 450 \text{ mm}$ (overall height)

$450 \text{ mm} - 10 \text{ mm}$ (beam separation) = 440 mm (detection height)

Detection height

Minimum = 100 mm

Maximum = 3,140 mm

Beam separation

Minimum = 10 mm

Maximum = 50 mm

B

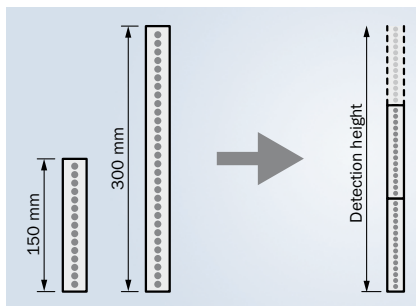

Simple interconnection of optics modules with lengths of 150 mm or 300 mm. Monitoring height determines how many modules to use.

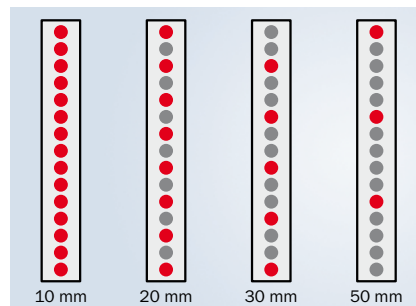

Beam separation varies depending on how the optics modules are equipped with LEDs. The smaller the beam separation, the higher the resolution will be. There is also an MLG variant with a beam separation of 25 mm.



For fast integration



B



Additional information

Detailed technical data B-45
 Ordering information B-46
 Dimensional drawing B-49
 Adjustments B-50
 Connection type and diagram . . . B-50
 Recommended accessories B-51
 Special functions B-52

Product description

The MLG CANopen has an integrated CANopen interface and is applied in measuring applications. Customers can choose the MLG for variable height measurement or for object classification. The MLG CANopen enables a lot of different configuration possibilities. The MLG is modular and can be ordered in different

detection heights and beam separation options. The software is related to CANopen 2.0 CIA/DS-301 version 4.1. This software specification provides easy integration using EDS data sets. The customer can choose between different mounting options for optimal installation.

At a glance

- Integrated CANopen interface
- Resolutions of 10 / 20 / 30 / 50 mm and customer-specific resolutions
- Working range up to 8.5 m
- Detection heights of over 3 m and up to 240 beams possible
- Short response time of < 9 ms
- Teach algorithm for optimal sensitivity settings in difficult applications

Your benefits

- The CANopen software is 2.0 CIA/DS-301 for easy integration in the control system
- Low cabling requirement reduces installation costs
- East-to-see light grid status information via the bus system helps avoid interrupting operation
- Different beam separation options, detection heights and output configurations ensure a reliable solution
- Robust metal housing stands up to tough environments and reduces downtime

→ www.mysick.com/en/MLG_CANopen

Detailed technical data

Features

Technology	Sender/receiver
Task	Measurement light grid
Minimum detectable object (MDO)	Parallel beam: 15 mm ... 60 mm
Number of beams	3 ... 240
Configuration	EDS file

Performance

Maximum range ¹⁾	7 m 12 m
Minimum range	Parallel beam: ≥ 0 mm
Response time ²⁾	Parallel beam: 9 ms ... 57 ms Cross beam: depending on type

¹⁾ No reserve for environmental issues and deterioration of the diode.

²⁾ With resistive load.

Interfaces

Inputs ¹⁾	1 x PNP
----------------------	---------

¹⁾ 1 x test input for sender.

Mechanics/electronics

Wave length	IR, 880 nm
Supply voltage V_s	DC 18 V ... 30 V
Power consumption sender ¹⁾	< 140 mA + 2 mA per beam
Power consumption receiver ¹⁾	< 100 mA + 3 mA per beam
Ripple	< 5 V_{SS}
Output current I_{max}	100 mA
Output load capacitive	100 nF
Output load inductive	1 H
Initialization time	1 s
Dimensions (W x H x D)	34 mm x 214 mm x 29 mm ... 34 mm x 3,335 mm x 29 mm
Housing material	Aluminum
Indication	LED, 7-segment display
Synchronization	Cable
Enclosure rating	IP 65
Circuit protection	V_s connections reverse-polarity protected Output Q short-circuit protected Interference suppression
Weight	0.73 kg ... 7.722 kg
Front screen	PMMA

¹⁾ Without load with load 24 V.

Ambient data

Protection class	III
EMC	EN 60947-5-2
Ambient temperature	Operation: -25 °C ... +55 °C Storage: -25 °C ... +70 °C
Ambient light safety ¹⁾	Direct: 12,500 lx Indirect: 50,000 lx
Vibration resistance	5 g, 10 Hz ... 55 Hz (IEC 68-2-6)
Shock load	10 g / DIN EN 60068-2-29 / 16 ms

¹⁾ Sunlight.

Ordering information

The part numbers below show a selection of our common configurations and represent only a portion of the product portfolio. The type code on page B-47 indicates all possible configurations that can be ordered.

Please note: Sender and receiver are only offered as a pair.

Connection type ¹⁾	Switching output ²⁾	Beam separation	Working range	Detection height	Model name	Part no.
Connector M12, 8-pin	1 x PNP	10 mm	5 m	290 mm	MLG1-0290C811	1053512
				2,390 mm	MLG1-2390C811	1055026
			8.5 m	2,390 mm	MLG1-2390C821	1055171
		20 mm	5 m	580 mm	MLG2-0580C811	1055172
				30 mm	5 m	1,470 mm
		50 mm	5 m	100 mm	MLG5-0100C811	1055174
					2,050 mm	MLG5-2050C811
				8.5 m	100 mm	MLG5-0100C821

¹⁾ With adapter M12, 5-pin.

²⁾ Switching output with adapter not usable.

Type code

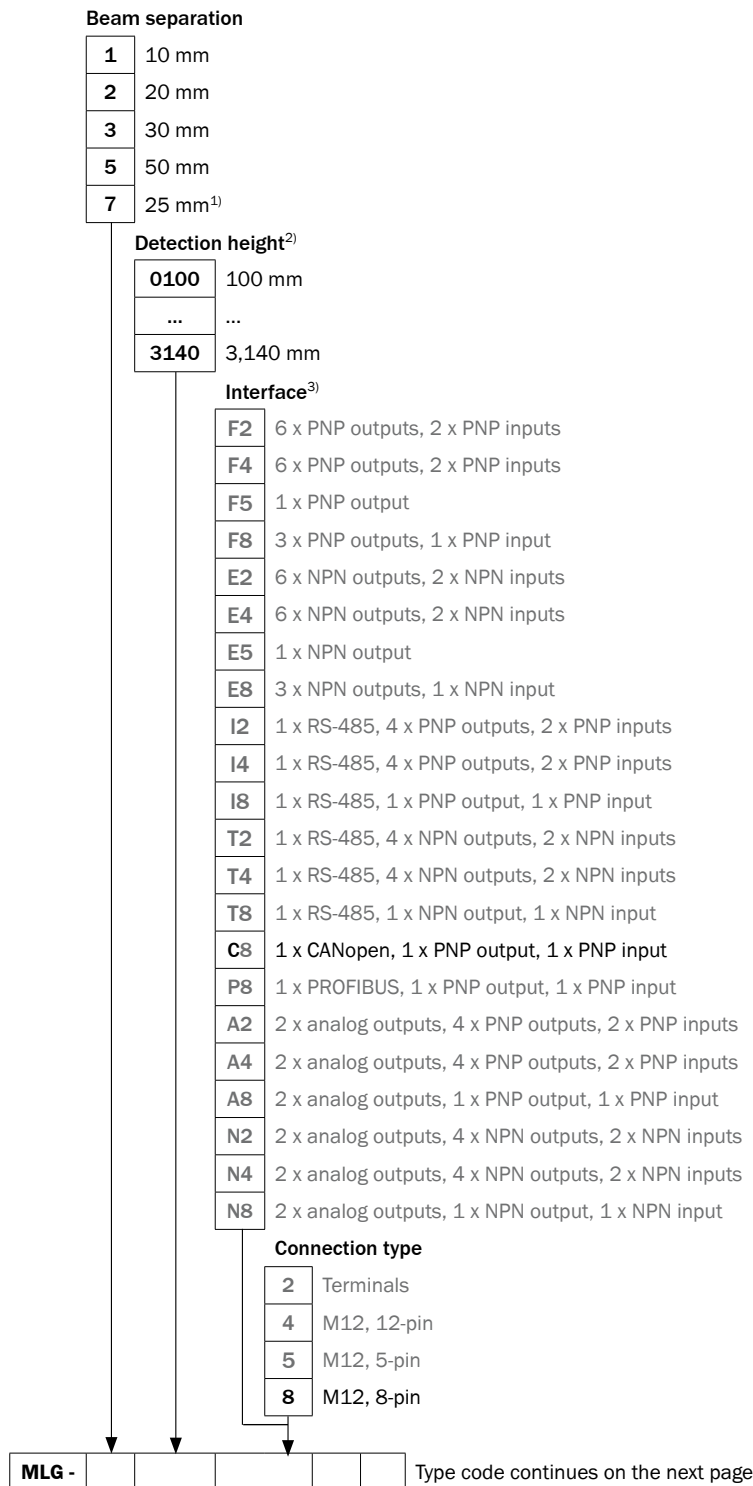

¹⁾ On demand.

²⁾ Max. 240 beams possible.

³⁾ Number refers to possible connection type.

B

Working range

1	5 m (open angle $\pm 3^\circ$), standard
2	8.5 m (open angle $\pm 3^\circ$), standard
3	20 m (open angle $\pm 10^\circ$) ¹⁾
4	5 m (open angle $\pm 10^\circ$)
5	8.5 m (open angle $\pm 10^\circ$)
6	5 m (open angle $\pm 1.8^\circ$) ¹⁾

Configuration

1	Standard (switching)
2	Configuration interface
3	Cross beam (3-times)
5	Cross beam (5-times) ¹⁾



¹⁾ On demand.

Dimensional drawing

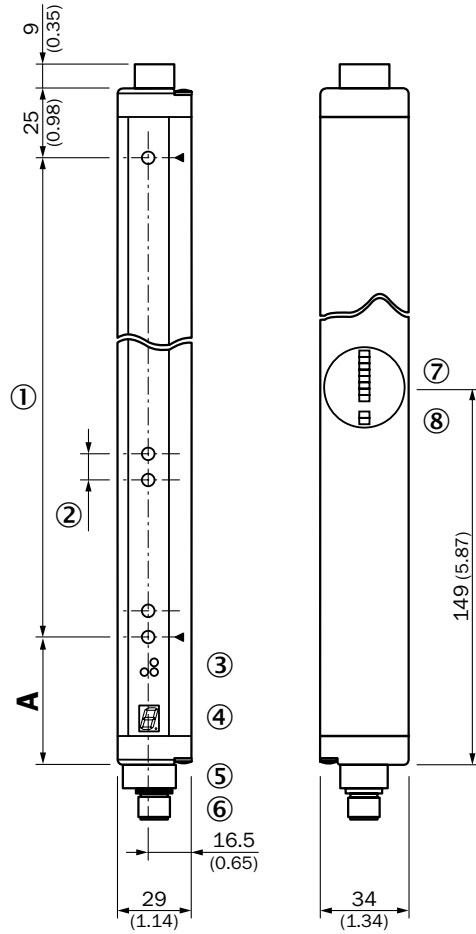

Dimensions in mm (inch)

	A
	Distance: MLG edge – first beam
Beam separation 10 mm	49 (1.93)
Beam separation 20 mm	49 (1.93) ¹⁾ / 59 (2.32) ²⁾
Beam separation 30 mm	69 (2.72)
Beam separation 50 mm	89 (3.50)

¹⁾ With even number of beams.
²⁾ With odd number of beams.

All dimensions in mm (inch)

- ① Detection height (see optical performance)
- ② Beam separation (10, 20, 30, 50 mm)
- ③ Status indicator: LEDs green, yellow, red
- ④ Indicator panel, 7-segment display
- ⑤ Ground
- ⑥ Connector M12, 8-pin (for CANopen adapter)
- ⑦ Address setting
- ⑧ Sensitivity baud rate

B

Adjustments

LED display receiver

B

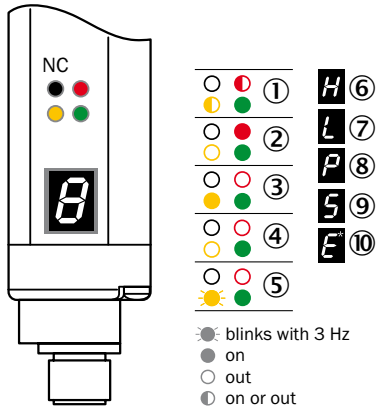

- ① Supply voltage
- ② Device error
- ③ No object in the light path
- ④ Object in the light path
- ⑤ Pollution indication or alignment aid
- ⑥ Blocked Beams Hold (BBH)
- ⑦ Activated teach-in procedure
- ⑧ ParamMode is active
- ⑨ Standby
- ⑩ Error: E1 = sync. error; E2 = less receiver signal; E9 = defect

Connection type and diagram

**Sender
Connector
M12, 5-pin**

**Receiver
Connector
M12, 8-pin**

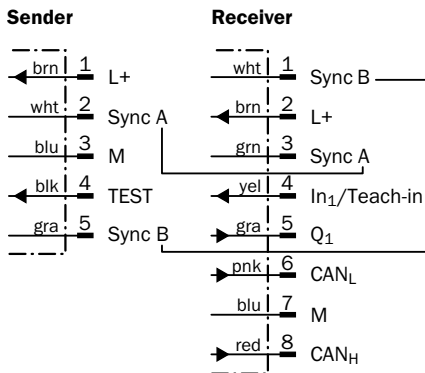
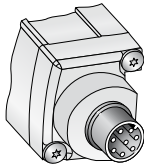
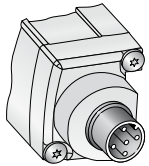



Recommended accessories



Complete accessories for the MLG CANopen include: 1 female connector, 1 bracket, 1 t-junction, 1 connection cable, 1 adapter and 1 termination resistor.

Please take note of the number of pins on the connector when choosing connection cables.







Adapters/distributors (without cable)

	Brief description	Model name	Part no.
	CAN adapter, straight	ADPT-CAN-GE-MLG	1052957
	T-junction, 1x plug M12, 5-pin and 2x socket M12, 5-pin	SBO-02G12-SM	6029305

Mounting brackets/plates

	Brief description	Model name	Part no.
	Mounting kit 1, adjustable, swivel mount, for all detection heights in small housings, plastic, without mounting material, 4 pcs	BEF-2SMKEAKU4	2019649
	Mounting kit, side bracket including four sliding nuts for MLG/ELG/HLG, 4 pcs	BEF-NUT-MLG	2023696
	Mounting bracket, steel, zinc coated, without mounting material, 4 pcs	BEF-WK-XLG	2029100

Plug connectors and cables

	Brief description	Model name	Part no.
	Female connector, M12, 5-pin, straight, 5 m, CAN	CAN cable 5 m (socket-open end)	6021166
 Illustration may differ	Female connector, M12, 5-pin, straight, 2 m, PVC	DOL-1205-G02M	6008899
	Female connector, M12, 5-pin, straight, 5 m, PVC	DOL-1205-G05M	6009868
	Female connector, M12, 5-pin, straight, 10 m, PVC	DOL-1205-G10M	6010544
	Female connector, M12, 5-pin, straight, 15 m, PVC	DOL-1205-G15M	6029215
 Illustration may differ	Female connector, M12, 5-pin, angled, 2 m, PVC	DOL-1205-W02M	6008900
	Female connector, M12, 5-pin, angled, 5 m, PVC	DOL-1205-W05M	6009869
	Female connector, M12, 5-pin, angled, 10 m, PVC	DOL-1205-W10M	6010542
 Illustration may differ	Female connector, M12, 5-pin, 5 m, PVC	DeviceNet cable	6030741
	Connection cable, M12, 5-pin, plug straight/socket straight, 5 m, PUR halogen free	DSL-1205-G05MC	6029282
	Connection cable, M12, 5-pin, plug straight/socket straight, 10 m, PUR halogen free	DSL-1205-G10MC	6038954
	Male connector, M12, 5-pin, straight, terminal resistor	STE-1205-GKEND	6037193

For additional accessories including dimensional drawings, please see page E-2.

Special functions

Modular construction

The advanced automation light grids are using a modular design principle. Every optics module has 15 beams. If you want to calculate the detection height, you have to subtract the single beam separation of the overall height of the optics modules.

E.g. $3 \times 150 \text{ mm} = 450 \text{ mm}$ (overall height)

$450 \text{ mm} - 10 \text{ mm}$ (beam separation) = 440 mm (detection height)

Detection height

Minimum = 100 mm

Maximum = 3,140 mm

Beam separation

Minimum = 10 mm

Maximum = 50 mm

B

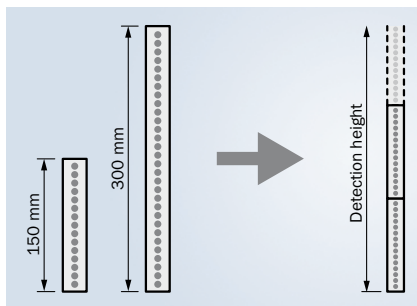

Simple interconnection of optics modules with lengths of 150 mm or 300 mm. Monitoring height determines how many modules to use.

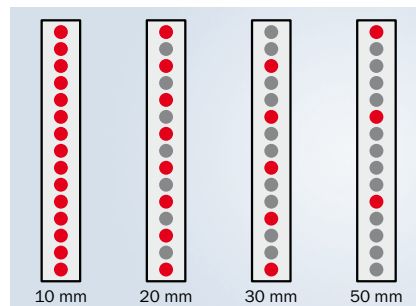

Beam separation varies depending on how the optics modules are equipped with LEDs. The smaller the beam separation, the higher the resolution will be. There is also an MLG variant with a beam separation of 25 mm.

B

Easy measuring with analog outputs



B



Additional information

Detailed technical data B-55
 Ordering information B-56
 Dimensional drawing B-59
 Adjustments B-60
 Connection type and diagram . . . B-60
 Recommended accessories B-61
 Special functions B-62

Product description

The modular light grid MLG with analog output and internal software features can be used for intelligent height measurement and positioning. The MLG has two analog outputs: 4 to 20 mA or 0 to 10 V. Two analog outputs allow size and

position measurement directly to an analog controller. A new teaching function (range setup) helps eliminate errors from reflective surfaces or semi-transparent objects.

At a glance

- Two analog outputs: voltage to current
- Resolutions of 10 / 20 / 30 / 50 mm and customer-specific resolutions
- Working range up to 8.5 m
- Detection heights of over 3 m and up to 240 beams possible
- Short response time of < 3 ms possible
- Teach algorithm for optimal sensitivity settings in difficult applications, such as measuring trans-lucent objects
- Easy-to-use setup software for customized applications with new features
- Software tools, such as height measurement, zoning, hole detection, and presence control make implementation of complex solutions achievable

Your benefits

- Intelligent evaluation software saves costs by quickly and easily turning a standard sensor into a custom problem solver, reducing the number of sensors, PLCs and programming required
- Easy-to-see status information helps avoid interrupting operation
- Different beam separation options, detection heights and output configurations ensure a reliable solution
- Integrated analog outputs reduce integration costs for measuring applications, because no additional software is necessary
- Discrete outputs for custom solutions without a PLC
- Tough metal housing stands up to harsh environments and reduces downtime

→ www.mysick.com/en/MLG_Analog_Output

Detailed technical data

Features

Technology	Sender/receiver
Task	Measurement light grid
Minimum detectable object (MDO)	Parallel beam: 15 mm ... 60 mm
Number of beams	3 ... 240
Configuration	Configuration interface (measuring)

Performance

Maximum range ¹⁾	7 m 12 m
Minimum range	Parallel beam: ≥ 0 mm
Response time ²⁾	Parallel beam: 1.5 ms ... 37 ms Cross beam: depending on type

¹⁾ No reserve for environmental issues and deterioration of the diode.

²⁾ With resistive load.

Interfaces

Inputs	2 x PNP 2 x NPN
--------	--------------------

Mechanics/electronics

Wave length	IR, 880 nm
Supply voltage V_s	DC 18 V ... 30 V
Power consumption sender ¹⁾	< 140 mA + 2 mA per beam
Power consumption receiver ¹⁾	< 100 mA + 3 mA per beam
Ripple	< 5 V_{ss}
Output current I_{max}	100 mA
Output load capacitive	100 nF
Output load inductive	1 H
Initialization time	1 s
Dimensions (W x H x D)	34 mm x 214 mm x 29 mm ... 34 mm x 3,335 mm x 29 mm
Housing material	Aluminum
Indication	LED, 7-segment display
Synchronization	Cable
Enclosure rating	IP 65
Circuit protection	V_s connections reverse-polarity protected Output Q short-circuit protected Interference suppression
Weight	0.73 kg ... 7.722 kg
Front screen	PMMA

¹⁾ Without load with 24 V.

²⁾ Typical value.

Ambient data

Protection class	III
EMC	EN 60947-5-2
Ambient temperature	Operation: -25 °C ... +55 °C Storage: -40 °C ... +70 °C
Ambient light safety ¹⁾	Direct: 12,500 lx Indirect: 50,000 lx
Vibration resistance	5 g, 10 Hz ... 55 Hz (IEC 68-2-6)
Shock load	10 g / DIN EN 60068-2-29 / 16 ms

¹⁾ Sunlight.

Specific data

Connection type	Switching output	Model name	Ordering information
Connector M12, 8-pin	2 x analog, 1 x PNP	MLGx-xxxxA8xx	B-56
	2 x analog, 1 x NPN	MLGx-xxxxN8xx	B-56

Ordering information

The part numbers below show a selection of our common configurations and represent only a portion of the product portfolio. The type code on page B-57 indicates all possible configurations that can be ordered.

Please note: Sender and receiver are only offered as a pair.

MLGx-xxxxA8xx

- **Connection type:** Connector M12, 8-pin
- **Switching output:** 2 x analog, 1 x PNP

Beam separation	Working range	Detection height	Model name	Part no.
10 mm	5 m	290 mm	MLG1-0290A812	1053489
		590 mm	MLG1-0990A812	1054673
		2,240 mm	MLG1-2240A812	1055177
	8.5 m	2,240 mm	MLG1-2240A822	1055178
20 mm	5 m	850 mm	MLG2-0580A812	1055179
30 mm	5 m	1,470 mm	MLG3-1470A812	1055180
50 mm	5 m	100 mm	MLG5-0100A812	1055181
		2,050 mm	MLG5-2050A812	1055182
	8.5 m	100 mm	MLG5-0100A822	1055183

MLGx-xxxxN8xx

- **Connection type:** Connector M12, 8-pin
- **Switching output:** 2 x analog, 1 x NPN

Beam separation	Working range	Detection height	Model name	Part no.
10 mm	5 m	2,240 mm	MLG1-2240N812	1055185
	8.5 m	2,240 mm	MLG1-2240N822	1055186
50 mm	5 m	100 mm	MLG5-0100N812	1055187
	8.5 m	100 mm	MLG5-0100N822	1055188

Type code

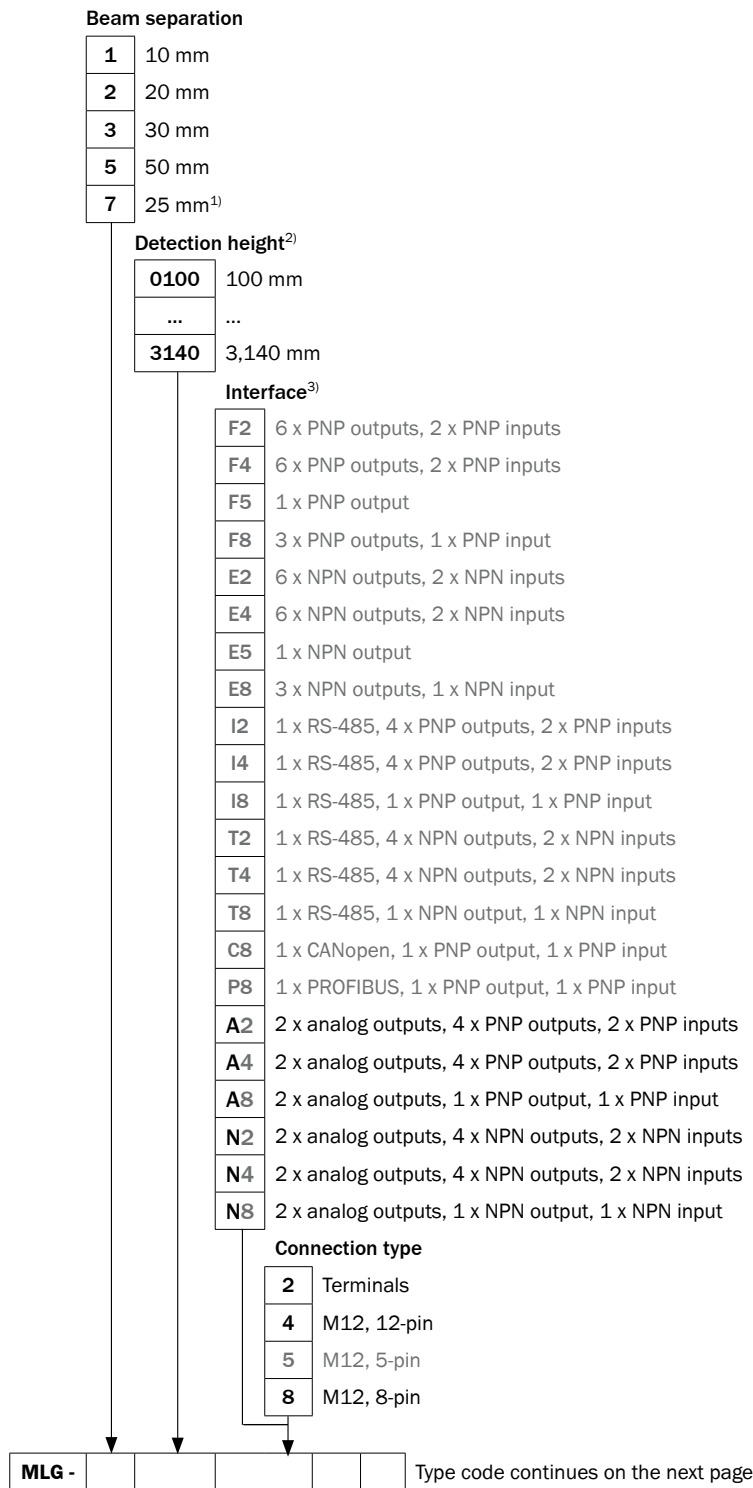

B

¹⁾ On demand.

²⁾ Max. 240 beams possible.

³⁾ Number refers to possible connection type.

B

Working range

1	5 m (open angle $\pm 3^\circ$), standard
2	8.5 m (open angle $\pm 3^\circ$), standard
3	20 m (open angle $\pm 10^\circ$) ¹⁾
4	5 m (open angle $\pm 10^\circ$)
5	8.5 m (open angle $\pm 10^\circ$)
6	5 m (open angle $\pm 1.8^\circ$) ¹⁾

Configuration

1	Standard (switching)
2	Configuration interface
3	Cross beam (3-times)
5	Cross beam (5-times) ¹⁾



¹⁾ On demand.

Dimensional drawing

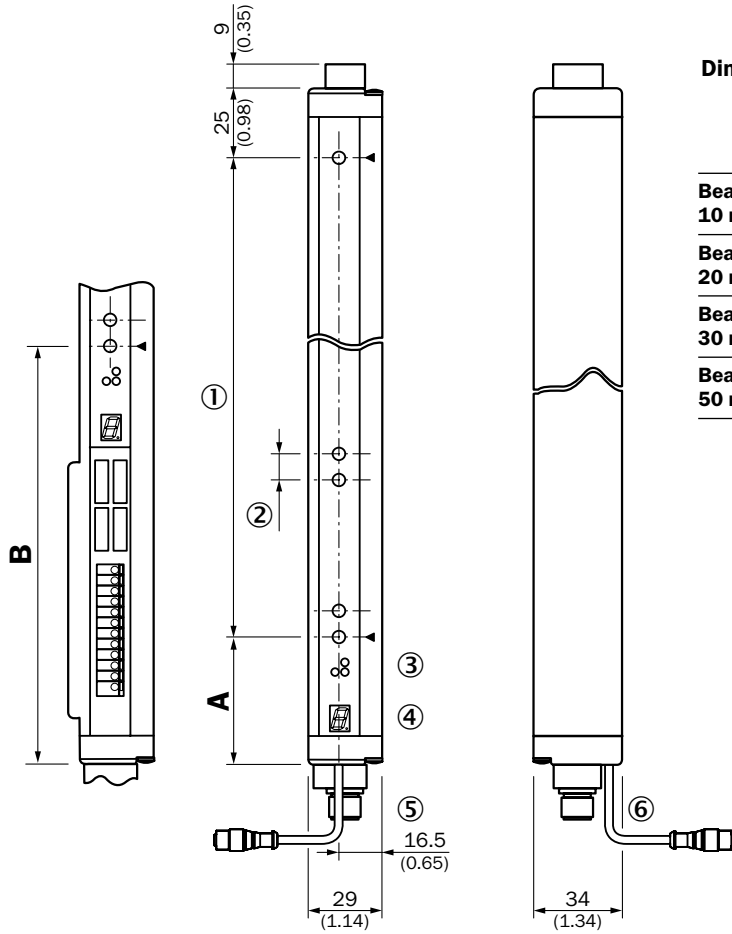

Dimensions in mm (inch)

	A	B
	Distance: MLG edge - first beam	
Beam separation MLG1		
10 mm	49 (1.93)	160 (6.30)
Beam separation MLG2		
20 mm	49 (1.93) ¹⁾ 59 (2.32) ²⁾	170 (6.69)
Beam separation MLG3		
30 mm	69 (2.72)	180 (7.09)
Beam separation MLG5		
50 mm	89 (3.50)	200 (7.87)

¹⁾ With even number of beams.
²⁾ With odd number of beams.

B

All dimensions in mm (inch)

- ① Detection height (see optical performance)
- ② Beam separation (10, 20, 30, 50 mm)
- ③ Status indicator: LEDs green, yellow, red
- ④ Indicator panel, 7-segment display
- ⑤ Terminals: M16 cable entry/connector M12, 12-pin
- ⑥ Configuration connector M8, 4-pin

Adjustments

LED display receiver

B

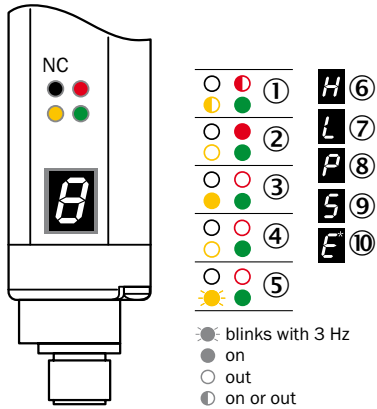

- ① Supply voltage
- ② Device error
- ③ No object in the light path
- ④ Object in the light path
- ⑤ Pollution indication or alignment aid
- ⑥ Blocked Beams Hold (BBH)
- ⑦ Activated teach-in procedure
- ⑧ ParamMode is active
- ⑨ Standby
- ⑩ Error: E1 = sync. error; E2 = less receiver signal; E9 = defect

Connection type and diagram

MLGx-xxxxx2xx
Sender
Terminals

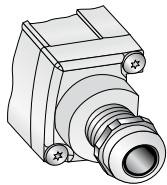

MLGx-xxxxx2xx
Receiver
Terminals

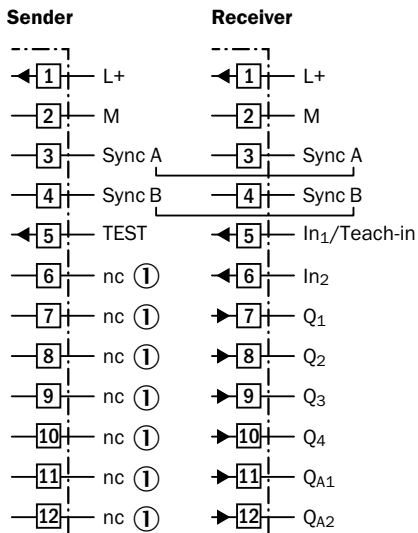
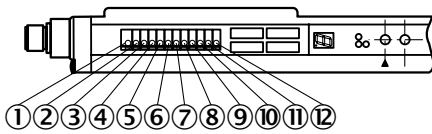

① Not connected

MLGx-xxxxx8xx
Sender
Connector
M12, 8-pin

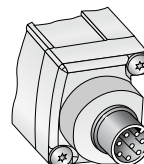

MLGx-xxxxx8xx
Receiver
Connector
M12, 8-pin

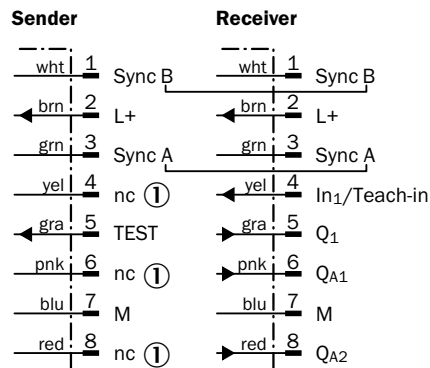
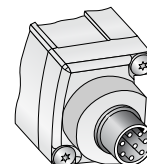

① Not connected

MLGx-xxxxx4xx
Sender
Connector
M12, 5-pin

MLGx-xxxxx4xx
Receiver
Connector
M12, 12-pin

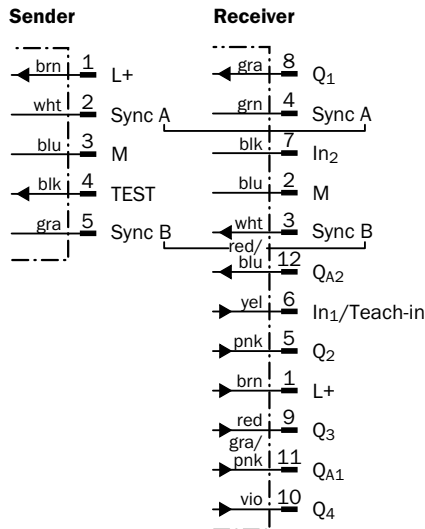
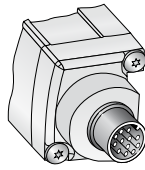
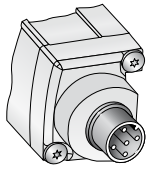

B

Recommended accessories



Complete accessories for the MLG Analog Output include: 1 female connector, 1 bracket, 1 t-junction and 1 connection cable.

Please take note of the number of pins on the connector when choosing connection cables.





Adapters/distributors (without cable)

	Brief description	Model name	Part no.
	T-junction, 1x plug M12, 8-pin and 2x socket M12, 8-pin	SBO-02F12-SM	6029306

Mounting brackets/plates

	Brief description	Model name	Part no.
	Mounting kit 1, adjustable, swivel mount, for all detection heights in small housings, plastic, without mounting material, 4 pcs	BEF-2SMKEAKU4	2019649
	Mounting kit, side bracket including four sliding nuts for MLG/ELG/HLG, 4 pcs	BEF-NUT-MLG	2023696
	Mounting bracket, steel, zinc coated, without mounting material, 4 pcs	BEF-WK-XLG	2029100

Plug connectors and cables

	Brief description	Model name	Part no.
 Illustration may differ	Female connector, M12, 8-pin, straight, 2 m, PVC, shielded	DOL-1208-G02MA	6020633
	Female connector, M12, 8-pin, straight, 5 m, PVC, shielded	DOL-1208-G05MA	6020993
	Female connector, M12, 8-pin, straight, 10 m, PVC, shielded	DOL-1208-G10MA	6022152
 Illustration may differ	Female connector, M12, 8-pin, angled, 2 m, PVC, shielded	DOL-1208-W02MA	6020992
	Female connector, M12, 8-pin, angled, 5 m, PVC, shielded	DOL-1208-W05MA	6021033
 Illustration may differ	Configuration cable, 2 m, PVC	DSL-8D04-G02M	2023695
 Illustration may differ	Connection cable, M12, 8-pin, plug straight/socket straight, 2 m, PUR halogen free, shielded	DSL-1208-G02MAC	6030121
	Connection cable, M12, 8-pin, plug straight/socket straight, 5 m, PUR halogen free, shielded	DSL-1208-G05MAC	6032325
	Connection cable, M12, 8-pin, plug straight/socket straight, 10 m, PUR halogen free, shielded	DSL-1208-G10MAC	6034901

B

For additional accessories including dimensional drawings, please see page E-2.

Special functions

Modular construction

The advanced automation light grids are using a modular design principle. Every optics module has 15 beams. If you want to calculate the detection height, you have to subtract the single beam separation of the overall height of the optics modules.

E.g. $3 \times 150 \text{ mm} = 450 \text{ mm}$ (overall height)
 $450 \text{ mm} - 10 \text{ mm}$ (beam separation) = 440 mm (detection height)

Detection height

Minimum = 100 mm
 Maximum = 3,140 mm

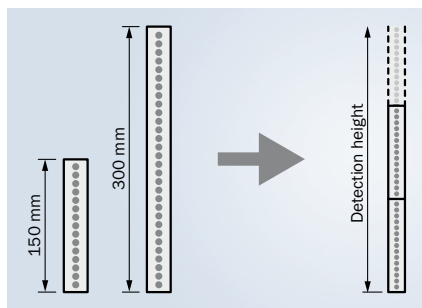

Simple interconnection of optics modules with lengths of 150 mm or 300 mm. Monitoring height determines how many modules to use.

Beam separation

Minimum = 10 mm
 Maximum = 50 mm

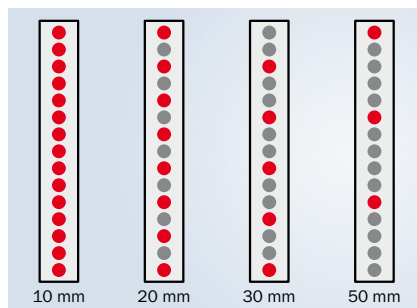

Beam separation varies depending on how the optics modules are equipped with LEDs. The smaller the beam separation, the higher the resolution will be. There is also an MLG variant with a beam separation of 25 mm.

B

Reliable measurement even in sunlight



B



Product description

The programmable version of the XLG automation light grid offers reliability, speed and flexibility. It has additional features compared to the MLG. The XLG's high immunity to infrared light and sunlight, the optional heated protective housing, and the scratch- and weather-

resistant front lens ensure a high level of reliability over long periods of time, even in the most adverse external conditions. Response times of only a few milliseconds and fast data output interfaces, such as RS-485, ensure it can operate in a wide range of outdoor applications.

At a glance

- Up to 6 x PNP or NPN switching outputs and two switching inputs
- Resolutions of 10 / 20 / 30 / 50 mm and customer-specific resolutions
- Working range up to 5 m
- Detection heights of over 3 m and up to 150 beams possible
- Short response time < 3 ms
- External teach-in for optimal sensitivity settings
- Highest immunity to sunlight
- Scratch-resistant front lens

Your benefits

- Highest immunity to sunlight for trouble-free operation
- Intelligent evaluation software saves costs
- Easy-to-see status information helps avoid interrupting operation
- Different beam separation options, detection heights and output configurations ensure a reliable solution



Additional information

Detailed technical data. B-65
 Ordering information. B-66
 Dimensional drawing B-68
 Adjustments B-69
 Connection type and diagram . . . B-69
 Recommended accessories. B-70
 Special functions. B-71

→ www.mysick.com/en/XLG_Programmable

Detailed technical data

Features

Technology	Sender/receiver
Task	Measurement light grid
Minimum detectable object (MDO)	Parallel beam: 15 mm ... 60 mm
Number of beams	3 ... 150
Configuration	Configuration interface (measuring)

Performance

Maximum range ¹⁾	7 m 12 m
Minimum range	Parallel beam: ≥ 0 mm
Response time ²⁾	Parallel beam: 1.5 ms ... 24 ms Cross beam: depending on type

¹⁾ No reserve for environmental issues and deterioration of the diode.

²⁾ With resistive load.

Interfaces

Inputs	2 x PNP
--------	---------

Mechanics/electronics

Wave length	IR, 880 nm
Supply voltage V_s	DC 18 V ... 30 V
Power consumption sender ¹⁾	< 140 mA + 2 mA per beam
Power consumption receiver ¹⁾	< 100 mA + 3 mA per beam
Ripple	< 5 V_{ss}
Output current I_{max}	100 mA
Output load capacitive	100 nF
Output load inductive	1 H
Initialization time	1 s
Dimensions (W x H x D)	34 mm x 214 mm x 29 mm ... 34 mm x 2,125 mm x 29 mm
Housing material	Aluminum
Indication	LED, 7-segment display
Synchronization	Cable
Enclosure rating	IP 65
Circuit protection	V_s connections reverse-polarity protected Output Q short-circuit protected Interference suppression
Weight	0.73 kg ... 6 kg
Front screen	PMMA

¹⁾ Without load with 24 V.

B

Ambient data

Protection class	III
EMC	EN 60947-5-2
Ambient temperature	Operation: -25 °C ... +55 °C Storage: -40 °C ... +70 °C
Ambient light safety ¹⁾	Direct: 150,000 lx Indirect: 200,000 lx
Vibration resistance	5 g, 10 Hz ... 55 Hz (IEC 68-2-6)
Shock load	10 g / DIN EN 60068-2-29 / 16 ms

¹⁾ Sunlight.

Ordering information

B

The part numbers below show a selection of our common configurations and represent only a portion of the product portfolio. The type code on page B-67 indicates all possible configurations that can be ordered.

Please note: Sender and receiver are only offered as a pair.

Beam separation	Working range	Detection height	Switching output	Connection type	Model name	Part no.
20 mm	5 m	1,180 mm	4 x PNP	Terminals	XLG2-1180I212	1048203
30 mm	5 m	1,020 mm	3 x PNP	Connector M12, 8-pin	XLG3-1020F812	1046353
		1,470 mm	3 x PNP	Connector M12, 8-pin	XLG3-1470F812	1047926
50 mm	5 m	1,900 mm	4 x PNP	Terminals	XLG5-1900I212	1048351

Type code

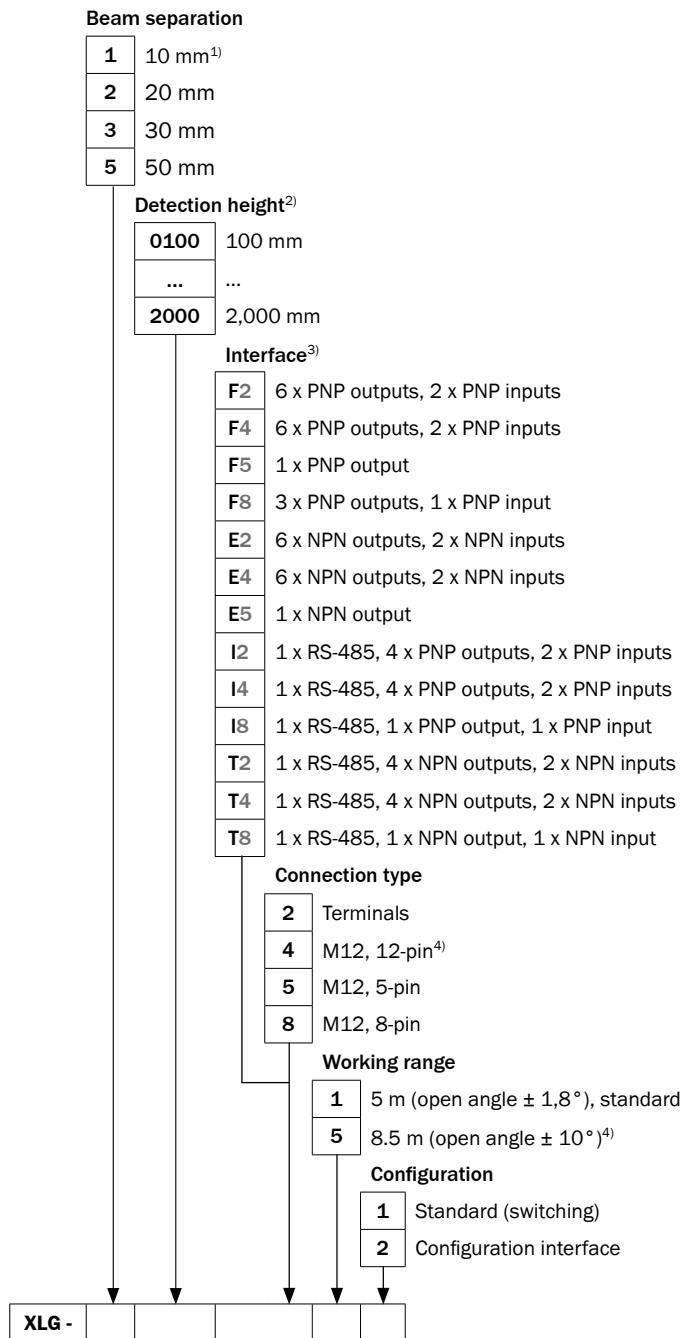

B

¹⁾ Only for PNP outputs.

²⁾ Max. 150 beams possible.

³⁾ Number refers to possible connection type.

⁴⁾ On demand.

Dimensional drawing

B

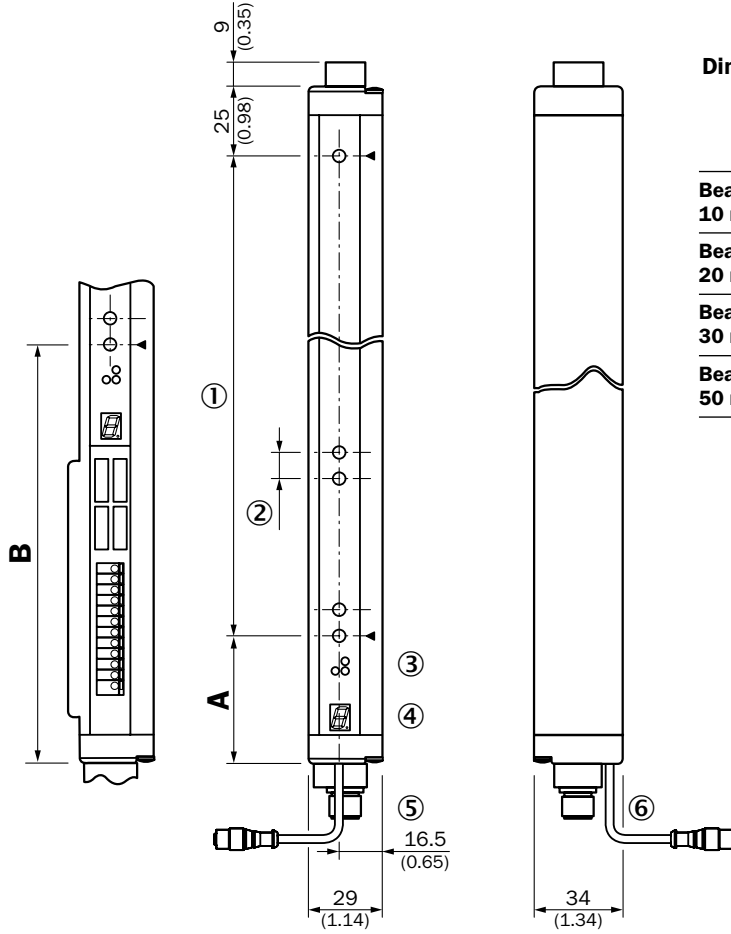

Dimensions in mm (inch)

	A	B
	Distance: XLG edge - first beam	
Beam separation XLG1		
10 mm	49 (1.93)	160 (6.30)
Beam separation XLG2		
20 mm	49 (1.93) ¹⁾	170 (6.69) ²⁾
Beam separation XLG3		
30 mm	69 (2.72)	180 (7.09)
Beam separation XLG5		
50 mm	89 (3.50)	200 (7.87)

¹⁾ With even number of beams.
²⁾ With odd number of beams.

All dimensions in mm (inch)

- ① Detection height (see optical performance)
- ② Beam separation (10, 20, 30, 50 mm)
- ③ Status indicator: LEDs green, yellow, red
- ④ Indicator panel, 7-segment display
- ⑤ Terminals: M16 cable entry/connector M12, 12-pin
- ⑥ Configuration connector M8, 4-pin

Adjustments

LED display receiver

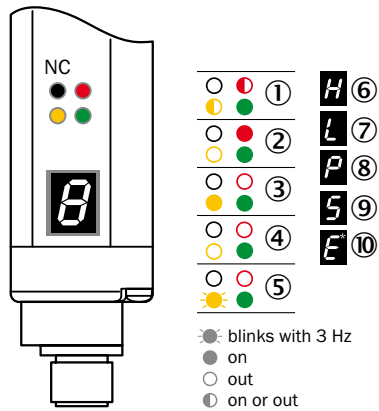

- ① Supply voltage
- ② Device error
- ③ No object in the light path
- ④ Object in the light path
- ⑤ Pollution indication or alignment aid
- ⑥ Blocked Beams Hold (BBH)
- ⑦ Activated teach-in procedure
- ⑧ ParamMode is active
- ⑨ Standby
- ⑩ Error: E1 = sync. error; E2 = less receiver signal; E9 = defect

Connection type and diagram

XLGx-xxxxx8xx
Sender
Connector
M12, 8-pin

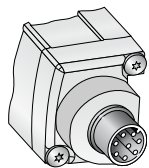

Sender

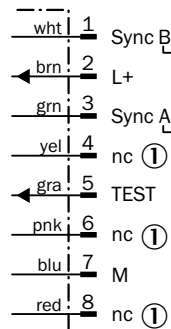

① Not connected

XLGx-xxxxx8xx
Receiver
Connector
M12, 8-pin

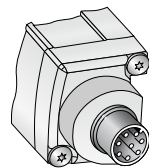

Receiver

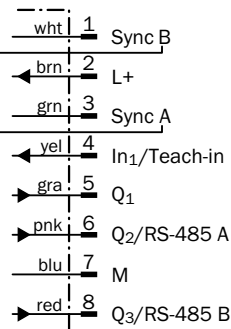

XLGx-xxxxx2xx
Sender
Terminals

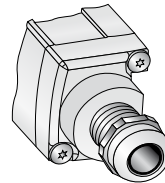

Sender

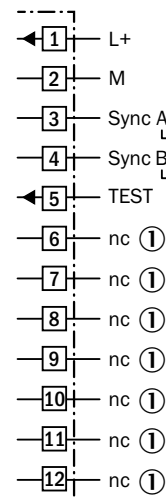

① Not connected

XLGx-xxxxx2xx
Receiver
Terminals

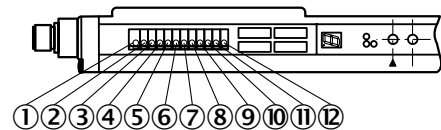

Receiver

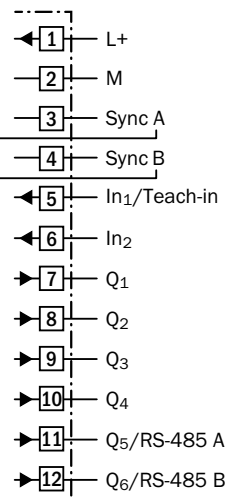

Recommended accessories



Complete accessories for the XLG Programmable include: 1 female connector, 1 bracket, 1 t-junction and 1 connection cable.

Please take note of the number of pins on the connector when choosing connection cables.



Adapters/distributors (without cable)

	Brief description	Model name	Part no.
	T-junction, 1x plug M12, 8-pin and 2x socket M12, 8-pin	SBO-02F12-SM	6029306



Mounting brackets/plates

	Brief description	Model name	Part no.
	Mounting kit 1, adjustable, swivel mount, for all detection heights in small housings, plastic, without mounting material, 4 pcs	BEF-2SMKEAKU4	2019649
	Mounting kit, side bracket including four sliding nuts for MLG/ELG/HLG, 4 pcs	BEF-NUT-MLG	2023696
	Mounting bracket, steel, zinc coated, without mounting material, 4 pcs	BEF-WK-XLG	2029100

Others

	Brief description	Model name	Part no.
	Acrylic glass tube as protective housing with screwable aluminum end cap	ALG IP housing	On demand
	Housing column for automation light grids, protection for outdoor applications	ALG protection housing	On demand

Plug connectors and cables

	Brief description	Model name	Part no.
 Illustration may differ	Female connector, M12, 8-pin, straight, 2 m, PVC, shielded	DOL-1208-G02MA	6020633
	Female connector, M12, 8-pin, straight, 5 m, PVC, shielded	DOL-1208-G05MA	6020993
	Female connector, M12, 8-pin, straight, 10 m, PVC, shielded	DOL-1208-G10MA	6022152
 Illustration may differ	Female connector, M12, 8-pin, angled, 2 m, PVC, shielded	DOL-1208-W02MA	6020992
	Female connector, M12, 8-pin, angled, 5 m, PVC, shielded	DOL-1208-W05MA	6021033
 Illustration may differ	Configuration cable, 2 m, PVC	DSL-8D04-G02M	2023695
	Connection cable, M12, 8-pin, plug straight/socket straight, 2 m, PUR halogen free, shielded	DSL-1208-G02MAC	6030121
	Connection cable, M12, 8-pin, plug straight/socket straight, 5 m, PUR halogen free, shielded	DSL-1208-G05MAC	6032325
	Connection cable, M12, 8-pin, plug straight/socket straight, 10 m, PUR halogen free, shielded	DSL-1208-G10MAC	6034901

For additional accessories including dimensional drawings, please see page E-2.

Special functions

Modular construction

The advanced automation light grids are using a modular design principle. Every optics module has 15 beams. If you want to calculate the detection height, you have to subtract the single beam separation of the overall height of the optics modules.

E.g. $3 \times 150 \text{ mm} = 450 \text{ mm}$ (overall height)

$450 \text{ mm} - 10 \text{ mm}$ (beam separation) = 440 mm (detection height)

Detection height

Minimum = 100 mm

Maximum = 3,140 mm

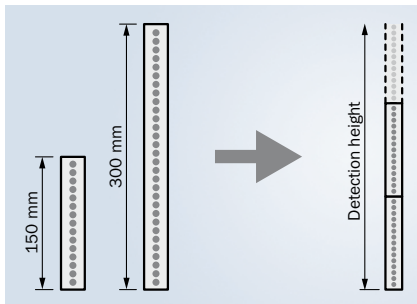

Simple interconnection of optics modules with lengths of 150 mm or 300 mm. Monitoring height determines how many modules to use.

Beam separation

Minimum = 10 mm

Maximum = 50 mm

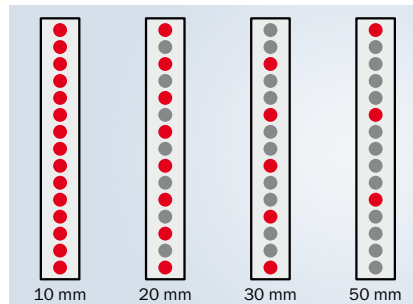

Beam separation varies depending on how the optics modules are equipped with LEDs. The smaller the beam separation, the higher the resolution will be. There is also an MLG variant with a beam separation of 25 mm.

B

C

Easily detect, inspect or count with standard automation light grids

The standard automation light grids from SICK can be used in a number of solutions, such as detecting and counting of irregularly shaped objects, checking for presence and overhang of pallet loads. Light grids from SICK offer multiple ranges, heights, sizes, orientations, and resolutions. All processing is integrated in the light grids for fast setup with no external controller needed.

Your benefits







- A wide range of standard automation light grids for a variety of applications
- Insensitive to ambient light when exposed to direct sunlight, strobe lights, and highly reflective objects, eliminating false trips
- Retro-reflective light grids for one-sided detection reduce installation costs and can be used in compact spaces
- Reliable leading edge detection on high-speed conveyors provides accurate and repeatable triggering
- Industry standard connections for quick connection and commissioning, reducing overall setup costs
- Simple installation, easy setup, and application-specific housing designs make SICK standard automation light grids an easy addition to increase throughput and decrease waste
- Light grid with integrated reflective tape on the rear for easy mounting





C

Standard automation light grids

	At a glance/applications	C-2
	Product family overview	C-6
	WLG Versatile, compact, reflex light grid	C-8
	HLG High-resolution and high-speed detection of the smallest objects	C-14
	ELG Short Range Reliable detection and counting	C-20
	ELG Long Range The tough automation light grid	C-28
	PLG3 Simply clever order picking verification	C-38
	PLG6 Increase pick rates in compact installations	C-44

Standard automation light grids – the switching solution suitable for your application



C

Standard automation light grids operate using the switching principle. They detect an object at any point in the measurement field and transfer the information “measurement field free” or “measurement field interrupted” to the switching output, Q. Unlike a measuring light grid, it can signal the presence of an object but not indicate its position or size.

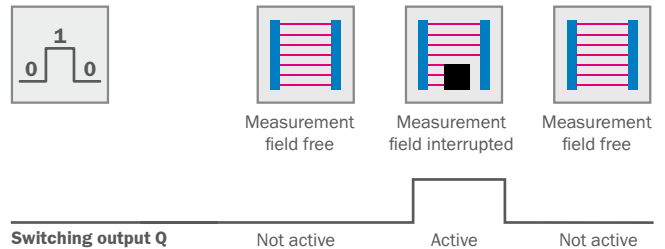

An overview of your advantages



WLG

- Reliably detects small, irregular shaped objects
- Also available as a measuring variant



HLG

- Fastest detection, also for flat objects like letters
- Easy installation thanks to mounting groove on the housing



ELG

- High immunity to ambient light
- Working range up to 12 m allow reliable use at longer distances



PLG

- Integrated 360° job LED for error-free picking
- Easy mounting and alignment thanks to the use of a reflector

WLG – reject control



Typical applications for the **WLG12** reflection light grid include counting small parts, including metallic items. Retro-reflective light grids are mainly used in packaging, pressing and stamping technology.



Recommended product	WLG (see page C-8)
Limiting range	1.5 m
Resolution (beam separation)	12.5 mm
Detection height	87.5 mm
Response time	0.6 ms (parallel beam)



C

HLG – edge control



In mail sorting systems, different shaped objects run on conveyor belts at high speed. To determine their exact length, the leading edge of the object must be reliably detected. Thanks to its high resolution and fast response time across the entire width of the conveyor belt, the **HLG** is the ideal solution for this application.



Recommended product	HLG (see page C-14)
Limiting range	2 m
Resolution (beam separation)	2 mm
Detection height	50 mm
Response time	3 ms (parallel beam)

ELG Short Range – separation control



At airports, suitcases must be arranged on conveyor belts before arriving in the passenger area so that they do not collide. The **ELG Short Range** can reliably detect the edges of objects and the leading edge of different suitcases.



Recommended product	ELG Short Range (see page C-20)
Limiting range	4 m ^{*)}
Resolution (beam separation)	10 mm / 30 mm
Detection height	90 mm ... 930 mm
Response time	14 ms ^{*)}

^{*)} Type-dependent.

C

ELG Long Range – monitoring industrial doors



The **ELG Long Range** offers high immunity to ambient light and a wide working range for monitoring industrial doors. The ELG Long Range is also the ideal solution for large detection heights.



Recommended product	ELG Long Range (see page C-28)
Limiting range	17 m
Resolution (beam separation)	30 mm / 60 mm
Detection height	150 mm ... 3,330 mm
Response time	28 ms ^{*)}

^{*)} Type-dependent.

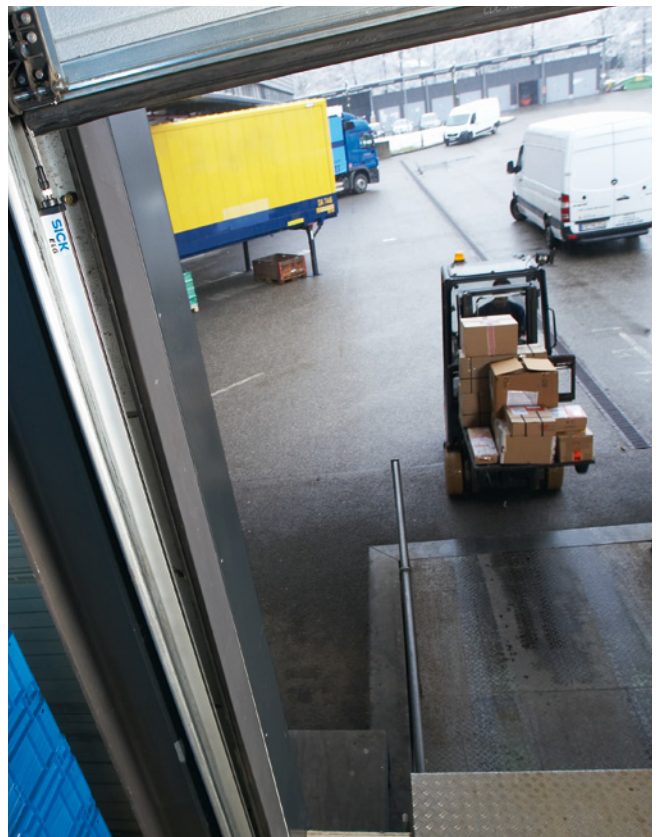

PLG – pick-to-light for error-free commissioning

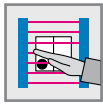

Task

When commissioning a production order (e.g., final assembly or engine production in the automotive industry) or a sales order in warehouses or distribution centers, various sub-quantities may have to be put together to complete the order or process. The objective is to ensure error-free picking and to reliably guide the machine operator.

Process

The PLG3 and PLG6 sensors are located in each storage bay and have an integrated job LED for displaying the picking position, confirming correct access or indicating an incorrect pick. A strip of reflective tape on the back side of every PLG3 and PLG6 sensor also serves as the reflector for the next PLG in the neighboring storage bay. The row also requires another strip of reflective tape.

Solutions



Thanks to an integrated polarizing filter, the **PLG3** is highly immune to glare. It has a 30 mm beam separation and is available with various detection heights. The integrated green job LED reduces order-picker search time.



With a beam separation of 60 mm, the **PLG6** is particularly suitable for short detection heights. At the front of the housing, it has an integrated red job LED that is visible to the worker at a 360° angle and can draw the worker's attention to the correct "picking" position or to faulty engagement.







C

Selection guide

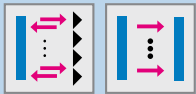

Light grid type	Chapter			Limiting range in m	Beam separation in mm	Detection height in mm	Job LED
PLG3	C-38						Green, visible from 360°
PLG6	C-44						Red, visible from 360°
SPL	D-20						Green, across entire light grid length at sender and receiver, visible from 180°

Product family overview

			
	WLG	HLG	ELG Short Range
	Versatile, compact, reflex light grid	High-resolution and high-speed detection of the smallest objects	Reliable detection and counting

Technical data overview			
Beam separation	12.5 mm	2 mm	10 mm 30 mm
Minimum detectable object (MDO)	Parallel beam: ≥ 6 mm ... 12 mm	Parallel beam: ≥ 2 mm	Parallel beam: ≥ 15 mm ... 35 mm Cross beam: ≥ 10 mm ... 20 mm
Working range	1.5 m	1.5 m	2 m 3 m 5 m
Detection height	87.5 mm	50 mm	90 mm ... 1,050 mm
Response time	Parallel beam: 0.6 ms	Parallel beam: 3 ms	Parallel beam: 14 ms ... 100 ms
Switching output	8 x PNP (Q and alarm) 1 x PNP (/Q) 2 x PNP (Q and /Q)	2 x PNP (Q and /Q) 2 x NPN (Q and /Q)	2 x PNP (Q and /Q) 2 x NPN (Q and /Q)
Connection type	Connector M12, 5-pin Cable 12-pin	Connector M12, 8-pin	Connector M12, 4-pin Cable 5 m

At a glance			
	<ul style="list-style-type: none"> The direct output of individual beams for measuring and switching Response time 0.6 ms Eight visible transmission LEDs Eight PNP switching outputs and one alarm output Sensitivity can be set via a potentiometer Polarizing filter to prevent reflexions for reflective surfaces 	<ul style="list-style-type: none"> 2 mm beam separation Response time 3 ms Detection height 50 mm Cable synchronization PNP or NPN with both Q and Qnot outputs (NO/NC) 1 x test, 1 x teach-in input Connector M12, 8-pin 	<ul style="list-style-type: none"> Up to 16 beams with 10 mm and 112 with 30 mm beam separation Range up to 5 m Potentiometer for sensitivity setting Ambient light up to 150,000 lux Tough, aluminum housing PNP/NPN output and a test input Optical synchronization

Further information			
Applications			
Detailed information	→ C-8	→ C-14	→ C-20

C



ELG Long Range

The tough automation light grid



PLG3

Simply clever order picking verification



PLG6

Increase pick rates in compact installations

	30 mm 60 mm	30 mm	60 mm
	Parallel beam: ≥ 35 mm ... 65 mm Cross beam: ≥ 20 mm ... 35 mm	Parallel beam: ≥ 35 mm	Parallel beam: ≥ 70 mm
	9 m 12 m	1.5 m	0.35 m
	150 mm ... 3,330 mm	120 mm ... 420 mm	60 mm
	Parallel beam: 28 ms ... 390 ms	Parallel beam: > 80 ms	Parallel beam: 5 ms
	2 x PNP (Q and /Q) 2 x NPN (Q and /Q) Relay (DC 60 V, AC 25 V)	PNP (Q)	PNP (Q)
	Connector M12, 4-pin Connector M12, 5-pin Cable 5 m Cable 15 m	Short cable (0.28 m) with connector M12, 4-pin	Short cable (0.28 m) with connector M12, 4-pin
	<ul style="list-style-type: none"> • Up to 128 beams • Different beam separations 30 mm and 60 mm • High functional reserve (gain) for ranges up to 12 m • Potentiometer for sensitivity setting • Ambient light up to 150,000 lux • Tough, aluminum housing • PNP/NPN/relay output and a test input • Optical synchronization 	<ul style="list-style-type: none"> • 360° visible job LED • Range up to 2 m • Flexible detection heights from 120 mm to 420 mm • Immune to reflected and ambient light • Switchable job LED: permanently lit or flashing • Optically confirms the right bin was picked • Bus connection possible 	<ul style="list-style-type: none"> • 360° visible job LED • Detection height 60 mm • Optically confirms the right bin was picked • Bus connection possible • The smallest pick-to-light light grid
	<p>→ C-28</p>	<p>→ C-38</p>	<p>→ C-44</p>

C

Versatile, compact, reflex light grid



Product description

The WLG is a retro-reflective light grid with a 100 mm detection height and 8 LEDs. Detecting damaged pallets, checking the edges of material webs and detecting and sorting bottles are ideal

applications for the WLG. It is possible to detect objects which are only 6 mm in size at a distance of 0.4 m. Transparent objects and reflective surfaces can also be detected reliably.

At a glance

- The direct output of individual beams for measuring and switching
- Response time 0.6 ms
- Eight visible transmission LEDs
- Eight PNP switching outputs and one alarm output
- Sensitivity can be set via a potentiometer
- Polarizing filter for reflective surfaces

Your benefits

- The WLG's fast response time keeps up with increased conveyor speeds, increasing throughput
- Detects translucent and semi-transparent objects for consistent detection of most objects
- Retro-reflective sensor saves space, installation time and cost
- Polarized retro-reflective light grids are designed to detect difficult reflective targets, such as stretch wrap and other thin films
- Visible red light reduces assembly time
- Multiple output versions indicate detection position and size of the object for closed loop process feedback and inspection



Additional information

Detailed technical data C-9
 Ordering information C-10
 Dimensional drawing C-10
 Adjustments C-10
 Connection type and diagram . . . C-11
 Recommended accessories C-12

→ www.mysick.com/en/WLG

C

Detailed technical data

Features

Technology	Retro-reflective light grid
Task	Switching light grid
Minimum detectable object (MDO)	Parallel beam: ≥ 6 mm ... 12 mm
Number of beams	8
Resolution (adjustable) ¹⁾	6 mm to 12.5 mm

¹⁾ Dependence of the range.

Performance

Maximum range	1.5 m
Minimum range	≥ 100 mm
Response time ¹⁾	Parallel beam: 0.6 ms

¹⁾ With resistive load.

Interfaces

Connection type	Connector M12, 5-pin Cable 12-pin
------------------------	--------------------------------------

Mechanics/electronics

Wave length	650 nm
Supply voltage V_s ¹⁾	DC 15 V ... 30 V
Power consumption sender ¹⁾	< 80 mA
Ripple	< 5 V _{PP}
Output current I_{max}	100 mA
Output load capacitive	100 nF
Output load inductive	1 H
Initialization time	0.6 s
Dimensions (W x H x D)	62 mm x 106 mm x 46.6 mm
Housing material	Aluminum
Indication	LED
Enclosure rating	IP 67
Circuit protection	V_s connections reverse-polarity protected Output Q short-circuit protected Interference suppression
Weight	230 g
Front screen	PMMA
Output mode ²⁾	Q dark switching
Teach input	PNP

¹⁾ Typical values.

²⁾ Q = active in case one beam is interrupted; /Q = active in case all beams are free.

Ambient data

Protection class	II
EMC	EN 60947-5-2
Ambient temperature	Operation: -25 °C ... $+55$ °C Storage: -20 °C ... $+70$ °C
Vibration resistance	5 g, 10 Hz ... 55 Hz (IEC 68-2-6)
Shock load	10 g / DIN EN 60068-2-29 / 16 ms

Ordering information

Beam separation	Working range	Detection height	Switching output	Model name	Part no.
12.5 mm	1.5 m	87.5 mm	8 x PNP (Q and alarm)	WLG12-G137	1016046
			1 x PNP (/Q)	WLG12-V537	1016045
			2 x PNP (Q and /Q)	WLG12-P537	1015798

Dimensional drawing

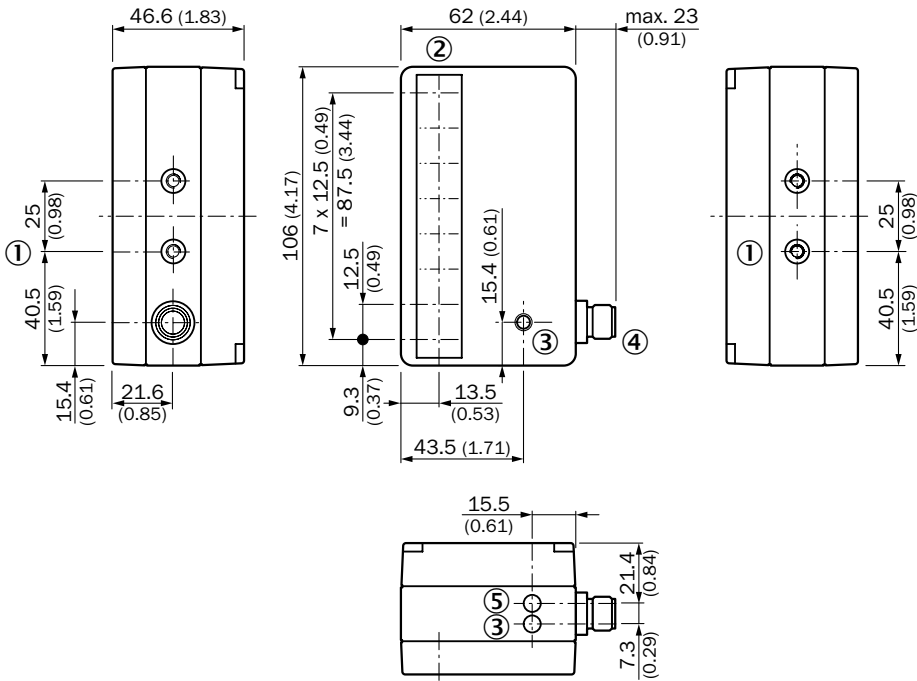

All dimensions in mm (inch)

- ① M5 threaded mounting hole, 6 mm deep
- ② Optic
- ③ Multi-function indicators at front and top: reception indicator, contamination indicator, teach-in error
- ④ Connector M12, 5-pin or cable 2 m
- ⑤ Operating indicator

Adjustments

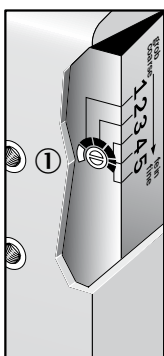

Choice of sensitivity range, dimensions in mm/m (inch)

Potentiometer setting	Resolution	Working range	Reflector
1	> 12.5 mm (0.49)	1.5 m (59.06)	2 x PL80A/PL40A
2	> 10 mm (0.39)	1.2 m (47.24)	2 x PL80A/PL40A
3	> 9 mm (0.35)	1.0 m (39.37)	PL180E01
4	> 7 mm (0.28)	0.8 m (31.50)	PL180E01
5	> 6 mm (0.24)	0.4 m (15.75)	PL180E01

- ① Potentiometer for sensitivity adjustment

Connection type and diagram

WLG12-G137

Cable
12-pin

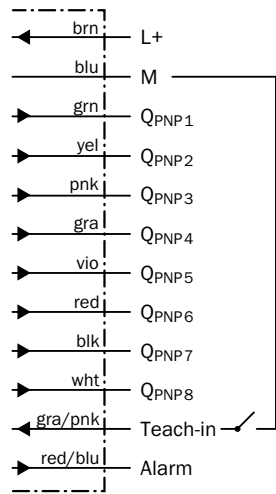
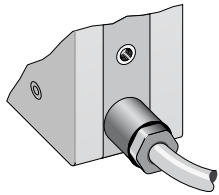

WLG12-V537 / WLG12-P537

Connector
M12, 5-pin

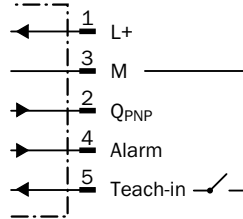
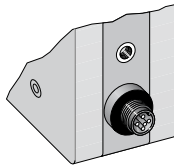

C

Recommended accessories





Complete accessories for the WLG include: 1 female connector, 1 bracket and 1 reflector.

Please take note of the number of pins on the connector when choosing connection cables.



Mounting brackets/plates

	Brief description	Model name	Part no.
	Mounting bracket for WLG12, steel, zinc coated, including mounting material	BEF-WN-WLG12	2017567

Reflectors

	Brief description	Model name	Part no.
	Reflector, 18 mm x 150 mm, plastic, self-adhesive	PL150	5315548
	Reflector, 40 mm x 180 mm, plastic, 2-hole mounting	PL180E01	1013289
	Reflector, 40 mm x 60 mm, plastic, 2-hole mounting	PL40A	1012720
	Reflector, 80 mm x 80 mm, plastic, 2-hole mounting	PL80A	1003865

Plug connectors and cables

	Brief description	Model name	Part no.
 Illustration may differ	Female connector, M12, 5-pin, straight, 2 m, PVC	DOL-1205-G02M	6008899
	Female connector, M12, 5-pin, straight, 5 m, PVC	DOL-1205-G05M	6009868
	Female connector, M12, 5-pin, straight, 10 m, PVC	DOL-1205-G10M	6010544
 Illustration may differ	Female connector, M12, 5-pin, angled, 2 m, PVC	DOL-1205-W02M	6008900
	Female connector, M12, 5-pin, angled, 5 m, PVC	DOL-1205-W05M	6009869
	Female connector, M12, 5-pin, angled, 10 m, PVC	DOL-1205-W10M	6010542

For additional accessories including dimensional drawings, please see page E-8

C

High-resolution and high-speed detection of the smallest objects



Product description

The high-resolution HLG light grid from SICK is the ideal solution for all applications in which very flat or small objects need to be detected. The HLG is particularly useful when the packages do not have a uniform leading or trailing edge, such as pillow and wedge-shaped

objects (bags and single serving size food packages). Its 2 mm resolution, fast 3 ms response time, and low switching hysteresis are ideal for fast mail handling systems, packaging machines with high throughput, and part ejection verification on molding and stamping machines.

At a glance

- 2 mm resolution
- Response time 3 ms
- Detection height 50 mm
- Cable synchronization
- PNP or NPN with both Q and Qnot outputs (NO/NC)
- 1 x test, 1 x teach-in input
- Connector M12, 8-pin

Your benefits

- Reliable object detection throughout the entire working range ensures consistent and reliable operation
- High availability thanks to its ability to detect very flat objects
- The HLG's short response time allows the use of higher conveyor speeds directly leading to higher throughput
- Cable synchronization provides more reliable use and higher machine uptime
- Highest measurement resolution provides smallest minimum detectable object size, for exact counting and true leading edge detection of conveyed objects, for more machine control and increased throughput



Additional information

Detailed technical data C-15

Ordering information C-16

Dimensional drawing C-16

Adjustments C-16

Connection type and diagram . . . C-17

Characteristic curve: MDO C-17

Recommended accessories C-18

→ www.mysick.com/en/HLG

C

Detailed technical data

Features

Technology	Sender/receiver
Task	Switching light grid
Minimum detectable object (MDO)	Parallel beam: ≥ 2 mm
Number of beams	26

Performance

Maximum range	2 m
Minimum range	≥ 0 mm
Response time ¹⁾	Parallel beam: 3 ms

¹⁾ With resistive load.

Interfaces

Connection type	Connector M12, 8-pin
-----------------	----------------------

Mechanics/electronics

Wave length	950 nm
Supply voltage V_s ¹⁾	DC 15 V ... 30 V
Power consumption sender ¹⁾	< 100 mA
Power consumption receiver ¹⁾	< 100 mA
Ripple	< 5 V_{pp}
Output current I_{max}	100 mA
Output load capacitive	100 nF
Output load inductive	1 H
Initialization time	0.8 s
Dimensions (W x H x D)	34 mm x 123 mm x 29 mm
Housing material	Aluminum
Indication	LED
Synchronization	Cable
Enclosure rating	IP 54
Circuit protection	V_s connections reverse-polarity protected Output Q short-circuit protected Interference suppression
Weight	135 g
Front screen	PMMA
Output mode ²⁾	Q dark switching
Teach input	PNP

¹⁾ Typical values.

²⁾ Q = active in case one beam is interrupted; /Q = active in case all beams are free.

Ambient data

Protection class	III
EMC	EN 60947-5-2
Ambient temperature	Operation: -25 °C ... +55 °C Storage: -40 °C ... +70 °C
Ambient light safety ¹⁾	Indirect: ≤ 50,000 lux
Vibration resistance	5 g, 10 Hz ... 55 Hz (IEC 68-2-6)
Shock load	10 g / DIN EN 60068-2-29 / 16 ms

¹⁾ Sunlight.

Ordering information

Please note: Sender and receiver are only offered as a pair.

Beam separation	Working range	Detection height	Switching output	Model name	Part no.
2 mm	1.5 m	50 mm	2 x PNP (Q and /Q)	HLG2-050F811	1029853
			2 x NPN (Q and /Q)	HLG2-050E811	1041849

Dimensional drawing

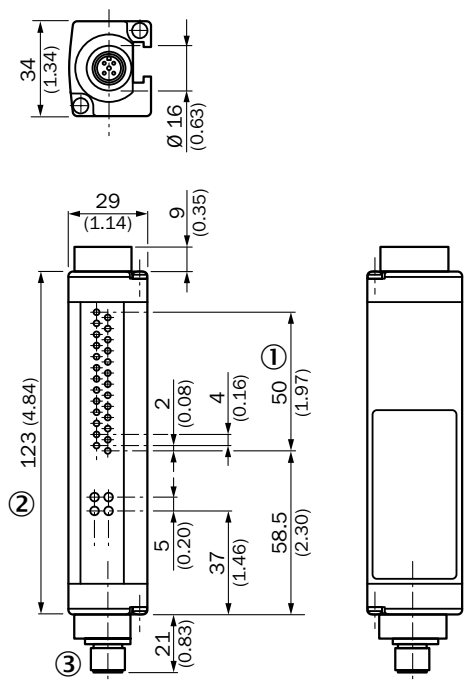

All dimensions in mm (inch)

- ① Detection height: 50 mm
- ② Status indicator/power on
- ③ Connector M12, 8-pin

Adjustments

Receiver, LED indication

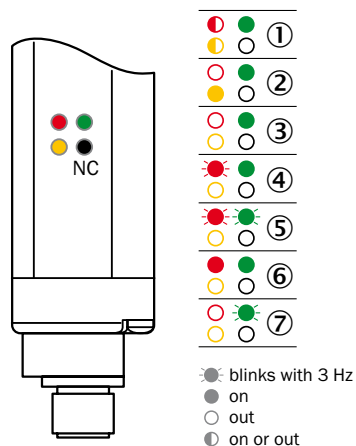

- ① Supply voltage
- ② No object in the light path
- ③ Light path interrupted
- ④ Synchronization error
- ⑤ Less received signal during teach-in
- ⑥ Device error
- ⑦ Activated teach-in procedure

Connection type and diagram

**Sender
Connector
M12, 8-pin**

**Receiver
Connector
M12, 8-pin**

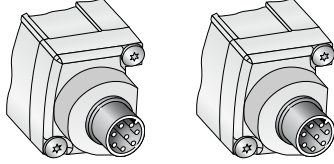

Sender

Receiver

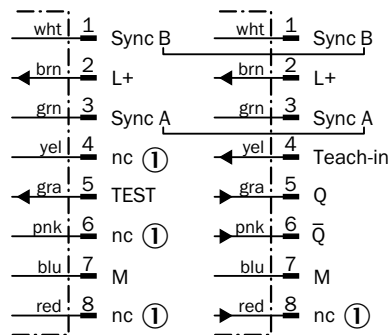

① Not connected

Characteristic curve: MDO

C

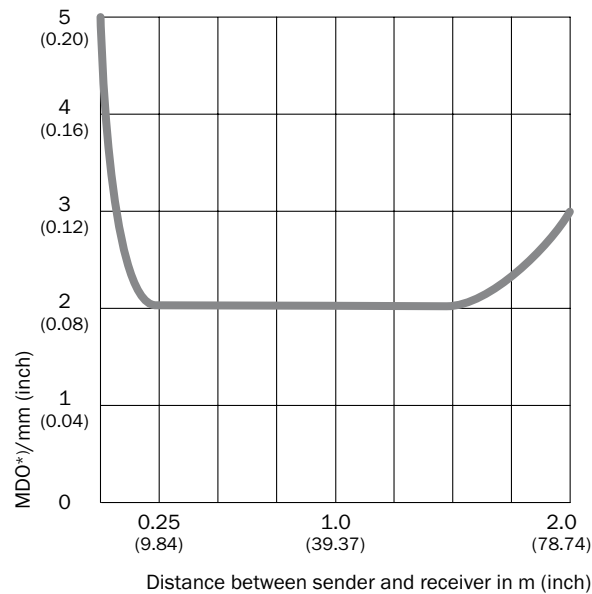

*) MDO: Minimum detectable object size measured in a direction parallel to the HLG

Recommended accessories



Complete accessories for the HLG include: 1 female connector, 1 bracket, 1 t-junction and 1 connection cable.

Please take note of the number of pins on the connector when choosing connection cables.





Adapters/distributors (without cable)

	Brief description	Model name	Part no.
	T-junction, 1 x connector M12, 8-pin, and 2 x socket M12, 8-pin	SBO-02F12-SM	6029306

Mounting brackets/plates

	Brief description	Model name	Part no.
	Mounting kit 1, adjustable, swivel mount, for all detection heights in small housings, plastic, without mounting material, 4 pcs	BEF-2SMKEAKU4	2019649
	Mounting bracket, steel, zinc coated, without mounting material, 4 pcs	BEF-WK-XLG	2029100

Plug connectors and cables

	Brief description	Model name	Part no.
 Illustration may differ	Female connector, M12, 8-pin, straight, 2 m, PVC, shielded	DOL-1208-G02MA	6020633
	Female connector, M12, 8-pin, straight, 5 m, PVC, shielded	DOL-1208-G05MA	6020993
	Female connector, M12, 8-pin, straight, 10 m, PVC, shielded	DOL-1208-G10MA	6022152
 Illustration may differ	Female connector, M12, 8-pin, angled, 5 m, PVC, shielded	DOL-1208-W05MA	6021033
	Female connector, M12, 8-pin, straight, shielded	DOS-1208-GA	6028369
	Connection cable, M12, 8-pin, connector straight/socket straight, 1 m, PUR halogen free, shielded	DSL-1208-G01MAC	6026625
	Connection cable, M12, 8-pin, connector straight/socket straight, 2 m, PUR halogen free, shielded	DSL-1208-G02MAC	6030121
	Connection cable, M12, 8-pin, connector straight/socket straight, 5 m, PUR halogen free, shielded	DSL-1208-G05MAC	6032325

For additional accessories including dimensional drawings, please see page E-8.

C

C

Reliable detection and counting



Product description

SICK offers the ELG Short Range (up to 3 m), an extremely tough switching automation light grid, with 10 and 30 mm beam separations and up to a 3,300 mm detection height. It is used in logistics for detecting the front edges of

objects and counting boxes. The cross beam function enables the detection of smaller parts. The ELG Short Range was developed for simple switching applications.

At a glance

- Up to 16 beams with 10 mm and 112 with 30 mm beam separation
- Range up to 5 m
- Potentiometer for sensitivity setting
- Ambient light up to 150,000 lux
- Tough, aluminum housing
- PNP/NPN output and a test input
- Optical synchronization

Your benefits

- Efficient and effective way to combine multiple sensors in one housing with one connector
- Simple commissioning thanks to a larger optical aperture angle and manual fine adjustment option
- Optical synchronization enables quick installation and cost-effective connection
- The ELG Short Range reliably detects objects, even under challenging ambient conditions



Additional information

Detailed technical data C-21

Ordering information C-22

Dimensional drawings C-24

Adjustments C-25

Connection type and diagram . . . C-26

Recommended accessories C-26

Special functions C-27

→ www.mysick.com/en/ELG_Short_Range

C

Detailed technical data

Features

Technology	Sender/receiver
Task	Switching light grid
Minimum detectable object (MDO)	Parallel beam: ≥ 35 mm ... 65 mm Cross beam: ≥ 20 mm ... 35 mm
Number of beams	4 ... 36

Performance

Maximum range	7 m
Minimum range	≥ 0 mm
Response time ¹⁾	Parallel beam: 14 ms ... 100 ms

¹⁾ With resistive load.

Interfaces

Connection type	Connector M12, 4-pin Cable 5 m
Test input	PNP

Mechanics/electronics

Wave length	880 nm
Supply voltage V_s ¹⁾	DC 15 V ... 30 V
Power consumption sender ¹⁾	< 100 mA
Power consumption receiver ¹⁾	< 100 mA
Ripple	< 5 V_{pp}
Output current I_{max}	100 mA
Output load capacitive	100 nF
Output load inductive	1 H
Initialization time	1 s
Dimensions (W x H x D)	34 mm x 187 mm x 29 mm ... 34 mm x 1,126 mm x 29 mm
Housing material	Aluminum
Indication	LED
Enclosure rating	IP 65
Circuit protection	V_s connections reverse-polarity protected Output Q short-circuit protected Interference suppression
Weight	700 g ... 2,900 g
Pulse rate	500 kHz 250 kHz
Front screen	PMMA
Output mode ²⁾	Q dark switching

¹⁾ Typical values.

²⁾ Q = active in case one beam is interrupted; /Q = active in case all beams are free.

C

Ambient data

Protection class	III
EMC	EN 60947-5-2
Ambient temperature	Operation: -25 °C ... +55 °C Storage: -40 °C ... +70 °C
Ambient light safety ¹⁾	Indirect: ≤ 150,000 lux
Vibration resistance	5 g, 10 Hz ... 55 Hz (IEC 68-2-6)
Shock load	10 g / DIN EN 60068-2-29 / 16 ms

¹⁾ Sunlight.

Specific data

Beam separation	Model name	Ordering information
10 mm	ELG1	C-22
30 mm	ELG3	C-22

Ordering information

The type code on page C-23 helps describe the coding of the ELG types. Further variants only upon request.

Please note: Sender and receiver are only offered as a pair.

ELG1

- Beam separation: 10 mm

Working range	Evaluation beams	Detection height	Switching output	Model name	Part no.
3 m	Multiple scan	100 mm	2 x PNP (Q and /Q)	ELG1-0100P533	1026808
		150 mm	2 x PNP (Q and /Q)	ELG1-0150P533	1026809
			2 x NPN (Q and /Q)	ELG1-0150N533	1029596
	Parallel beam	100 mm	2 x PNP (Q and /Q)	ELG1-0100P531	1026807
			2 x NPN (Q and /Q)	ELG1-0100N531	1053096
		150 mm	2 x PNP (Q and /Q)	ELG1-0150P531	1026741
5 m	Parallel beam	150 mm	2 x PNP (Q and /Q)	ELG1-0150P571	1028333

ELG3

- Beam separation: 30 mm

Working range	Evaluation beams	Detection height	Switching output	Model name	Part no.
2 m	Parallel beam	90 mm	2 x PNP (Q and /Q)	ELG3-0090P511	1024290
			2 x NPN (Q and /Q)	ELG3-0090N511	1041095
		210 mm	2 x PNP (Q and /Q)	ELG3-0210P511	1025510
		330 mm	2 x PNP (Q and /Q)	ELG3-0330P511	1025575
			2 x NPN (Q and /Q)	ELG3-0330N511	1042302
		390 mm	2 x PNP (Q and /Q)	ELG3-0390P591	1042615
		450 mm	2 x PNP (Q and /Q)	ELG3-0450P511	1025490
			2 x NPN (Q and /Q)	ELG3-0450P591	1029489
		570 mm	2 x PNP (Q and /Q)	ELG3-0570P511	1025501
		690 mm	2 x PNP (Q and /Q)	ELG3-0690P511	1025499
			2 x NPN (Q and /Q)	ELG3-0690N511	1041956

Dimensional drawings

ELG1

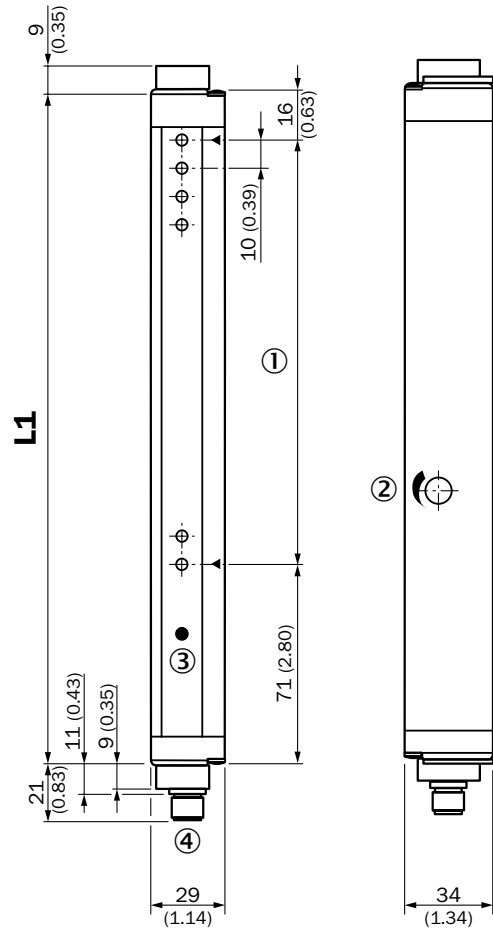

Dimensions in mm (inch)

L1

① 100 mm	187 (7.36)
① 150 mm	237 (9.33)

C

All dimensions in mm (inch)

- ① Detection height
- ② Sensitivity adjustment
- ③ Status indicator (ELGE)/power on (ELGS)
- ④ Connector M12, 4-pin

ELG3

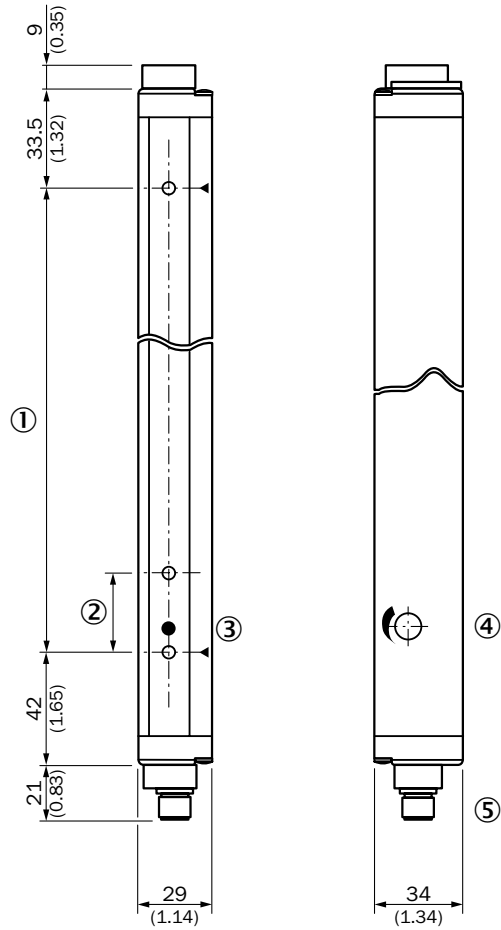

All dimensions in mm (inch)

- ① Detection height
- ② Beam separation ELG3: 30 mm
- ③ Status indicator (ELGE)/power on (ELGS)
- ④ Sensitivity adjustment
- ⑤ Connector M12, 4-pin

Adjustments

LED display sender

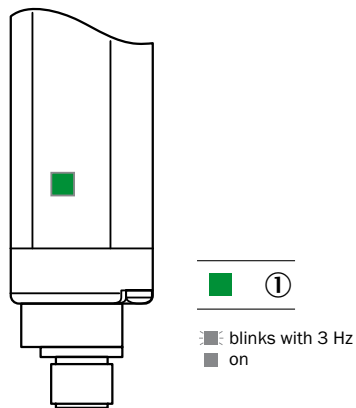

① Supply voltage

LED display receiver

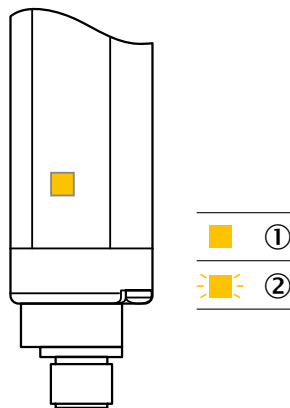

① No object in the light path
② Pollution indication

Connection type and diagram

Sender Connector
M12, 4-pin

Receiver Connector
M12, 4-pin

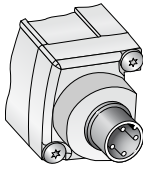
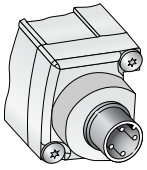

Sender

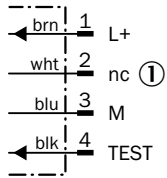

Receiver

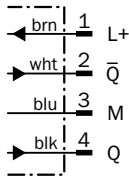

① Not connected

Recommended accessories

Complete accessories for the ELG Short Range include: 2 female connector cables and 1 bracket.

Please take note of the number of pins on the connector when choosing connection cables.

C

Mounting brackets/plates

	Brief description	Model name	Part no.
	Mounting kit 1, adjustable, swivel mount, for all detection heights in small housings, plastic, without mounting material, 4 pcs	BEF-2SMKEAKU4	2019649
	Mounting kit, side bracket including four sliding nuts for MLG/ELG/HLG, 4 pcs	BEF-NUT-MLG	2023696
	Mounting bracket, steel, zinc coated, without mounting material, 4 pcs	BEF-WK-XLG	2029100

Plug connectors and cables

	Brief description	Model name	Part no.
 Illustration may differ	Female connector, M12, 4-pin, straight, 2 m, PVC	DOL-1204-G02M	6009382
	Female connector, M12, 4-pin, straight, 5 m, PVC	DOL-1204-G05M	6009866
	Female connector, M12, 4-pin, straight, 10 m, PVC	DOL-1204-G10M	6010543
 Illustration may differ	Female connector, M12, 4-pin, angled, 2 m, PVC	DOL-1204-W02M	6009383
	Female connector, M12, 4-pin, angled, 5 m, PVC	DOL-1204-W05M	6009867
	Female connector, M12, 4-pin, angled, 10 m, PVC	DOL-1204-W10M	6010541

For additional accessories including dimensional drawings, please see page E-8.

Special functions

Sensitivity adjustment

1. Remove cap

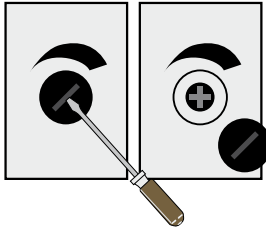

Remove cap with screw driver.

2. Potentiometer adjustment

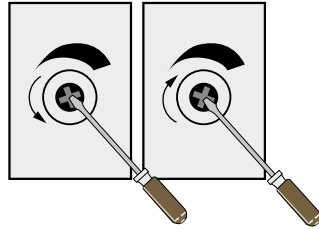

Turn left = for a lower range.
Turn right = for a higher range.

Sensitivity adjustment

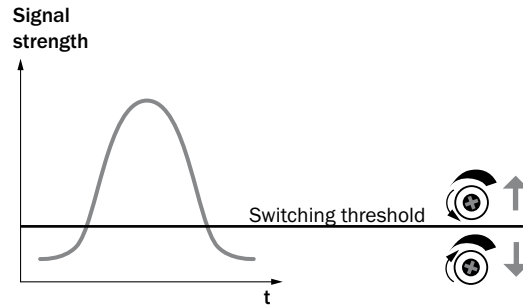

Optical synchronisation

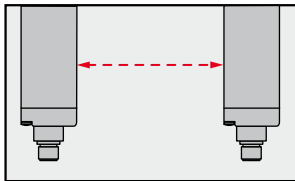

The light grid communicates via the light beams. A cable is not necessary for the optical synchronisation.

C

The tough automation light grid



Product description

The ELG Long Range (up to 12 m) automation light grid is extremely tough and offers different detection heights and beam separations. The ELG is immune to glare caused by light. It is used in logistics for checking for overhang on

pallets and counting boxes. The ELG is used mainly for the protection of industrial roller shutter gates and outdoors to separate vehicles. The ELG is available with up to 128 beams and with a minimum beam resolution of 30 mm.

At a glance

- Up to 128 beams
- Different beam separations 30 mm and 60 mm
- High functional reserve (gain) for ranges up to 12 m
- Potentiometer for sensitivity setting
- Ambient light up to 150,000 lux
- Tough, aluminum housing
- PNP/NPN/relay output and a test input
- Optical synchronization

Your benefits

- Insensitive to ambient light when exposed to direct sunlight, strobe lights, and highly reflective objects, eliminating false trips
- High functional reserve (excess gain) ensures operation even if it gets dirty, dusty, or misaligned, reducing maintenance costs
- Efficient and effective way to combine multiple sensors in one housing with one connector
- Simple commissioning thanks to a larger optical aperture angle and manual fine adjustment option
- Optical synchronization enables quick installation and cost-effective connection
- The sensitivity adjustment can be used to detect or ignore translucent materials to reduce production problems



Additional information

Detailed technical data C-29

Ordering information C-30

Dimensional drawings C-33

Adjustments C-34

Connection type and diagram . . . C-34

Recommended accessories C-35

Special functions C-36

→ www.mysick.com/en/ELG_Long_Range

C

Detailed technical data

Features

Technology	Sender/receiver
Task	Switching light grid
Minimum detectable object (MDO)	Parallel beam: ≥ 35 mm ... 65 mm Cross beam: ≥ 20 mm ... 35 mm
Number of beams	6 ... 80

Performance

Maximum range	13 m ... 17 m
Minimum range	≥ 0 mm ... ≥ 900 mm
Response time ¹⁾	Parallel beam: 28 ms ... 390 ms

¹⁾ With resistive load.

Interfaces

Connection type	Connector M12, 4-pin Connector M12, 5-pin Cable 5 m Cable 15 m
Test input	PNP

Mechanics/electronics

Wave length	880 nm
Supply voltage V_s ¹⁾	DC 15 V ... 30 V
Power consumption sender ¹⁾	< 100 mA
Power consumption receiver ¹⁾	< 100 mA
Ripple	< 5 V _{PP}
Output current I_{max}	100 mA
Output load capacitive	100 5F
Output load inductive	1 H
Initialization time	1 s
Dimensions (W x H x D)	34 mm x 226 mm x 29 mm ... 34 mm x 3,196 mm x 29 mm
Housing material	Aluminum
Indication	LED
Enclosure rating	IP 65
Circuit protection	V_s connections reverse-polarity protected Output Q short-circuit protected Interference suppression
Weight	800 g ... 7,700 g
Pulse rate	250 kHz 500 kHz 313 kHz
Front screen	PMMA
Output mode ²⁾	Q dark switching ²⁾ , light switching ³⁾

¹⁾ Typical values.

²⁾ ELG3/6: Q = active in case one beam is interrupted; /Q = active in case all beams are free.

³⁾ ELG3/6-Relay: NC = closed in case one beam is interrupted, NO = closed in case all beams are free.

C

Ambient data

Protection class	III
EMC	EN 60947-5-2
Ambient temperature	Operation: -25 °C ... +55 °C Storage: -40 °C ... +70 °C
Ambient light safety ¹⁾	Indirect: ≤ 150,000 lux
Vibration resistance	5 g, 10 Hz ... 55 Hz (IEC 68-2-6)
Shock load	10 g / DIN EN 60068-2-29 / 16 ms

¹⁾ Sunlight.

Specific data

Beam separation	Model name	Ordering information
30 mm	ELG3	C-30
	ELG3-Relay	C-31
60 mm	ELG6	C-31
	ELG6-Relay	C-32

Ordering information

The type code on page C-32 helps describe the coding of the ELG types. Further variants only upon request.

Please note: Sender and receiver are only offered as a pair.



ELG3

- Beam separation: 30 mm

Working range	Evaluation beams	Detection height	Switching output	Model name	Part no.
9 m	Parallel beam	210 mm	2 x NPN (Q and /Q)	ELG3-0210N541	1047484
		210 mm	2 x PNP (Q and /Q)	ELG3-0210P561	1046812
12 m	Parallel beam	450 mm	2 x PNP (Q and /Q)	ELG3-0450P561	1027894
		150 mm	2 x PNP (Q and /Q)	ELG3-0150P521	1026475
			2 x NPN (Q and /Q)	ELG3-0150N521	1047932
		210 mm	2 x PNP (Q and /Q)	ELG3-0210P521	1025574
			2 x NPN (Q and /Q)	ELG3-0210N521	1025613
		450 mm	2 x PNP (Q and /Q)	ELG3-0450P521	1025440
			2 x NPN (Q and /Q)	ELG3-0450N521	1025614
		570 mm	2 x PNP (Q and /Q)	ELG3-0570P521	1025885
		690 mm	2 x PNP (Q and /Q)	ELG3-0690P521	1025568
			2 x NPN (Q and /Q)	ELG3-0690N521	1025615
		810 mm	2 x PNP (Q and /Q)	ELG3-0810P521	1025577
		930 mm	2 x PNP (Q and /Q)	ELG3-0930P521	1025511
			2 x NPN (Q and /Q)	ELG3-0930N521	1025616
		1,050 mm	2 x PNP (Q and /Q)	ELG3-1050P521	1025570
		1,170 mm	2 x PNP (Q and /Q)	ELG3-1170P521	1025579
			2 x NPN (Q and /Q)	ELG3-1170N521	1025617
1,410 mm	2 x PNP (Q and /Q)	ELG3-1410P521	1025502		
	2 x NPN (Q and /Q)	ELG3-1410N521	1025618		
1,650 mm	2 x PNP (Q and /Q)	ELG3-1650P521	1025503		
	2 x NPN (Q and /Q)	ELG3-1650N521	1025620		

Working range	Evaluation beams	Detection height	Switching output	Model name	Part no.
12 m	Parallel beam	1,890 mm	2 x PNP (Q and /Q)	ELG3-1890P521	1025504
			2 x NPN (Q and /Q)	ELG3-1890N521	1025621
		2,070 mm	2 x PNP (Q and /Q)	ELG3-2070P521	1025505
		2,370 mm	2 x PNP (Q and /Q)	ELG3-2370P521	1025573
	Multiple scan	810 mm	2 x PNP (Q and /Q)	ELG3-0810P523	1026177
			2 x PNP (Q and /Q)	ELG3-1170P523	1040580
			2 x PNP (Q and /Q)	ELG3-1410P523	1026179
			2 x PNP (Q and /Q)	ELG3-1890P523	1026826
			2 x PNP (Q and /Q)	ELG3-2070P523	1025572
			2 x PNP (Q and /Q)	ELG3-2370P523	1026178

ELG3-Relay

- Beam separation: 30 mm

Working range	Evaluation beams	Detection height	Switching output	Model name	Part no.
12 m	Parallel beam	450 mm	Relay (DC 60 V, AC 25 V)	ELG3-0450R221	1024268
			Relay (DC 60 V, AC 25 V)	ELG3-0930R121	1025785
		930 mm	Relay (DC 60 V, AC 25 V)	ELG3-0930R221	1026176
			Relay (DC 60 V, AC 25 V)	ELG3-0930R521	1025449
	1,890 mm	Relay (DC 60 V, AC 25 V)	ELG3-1890R121	1026180	
	Multiple scan	930 mm	Relay (DC 60 V, AC 25 V)	ELG3-0930R523	1026537

ELG6

- Beam separation: 60 mm

Working range	Evaluation beams	Detection height	Switching output	Model name	Part no.
9 m	Parallel beam	900 mm	2 x NPN (Q and /Q)	ELG6-0900N541	1041568
12 m	Parallel beam	900 mm	2 x PNP (Q and /Q)	ELG6-0900P521	1025447
		1,080 mm	2 x PNP (Q and /Q)	ELG6-1080P521	1025586
		1,200 mm	2 x PNP (Q and /Q)	ELG6-1200P561	1044292
		1,380 mm	2 x PNP (Q and /Q)	ELG6-1380P561	1043870
			2 x PNP (Q and /Q)	ELG6-1380P521	1025587
		1,620 mm	2 x PNP (Q and /Q)	ELG6-1620P521	1040686
		1,860 mm	2 x PNP (Q and /Q)	ELG6-1860P521	1025589
		2,340 mm	2 x PNP (Q and /Q)	ELG6-2340P521	1025596
		3,120 mm	2 x PNP (Q and /Q)	ELG6-3120P521	1047475
		Multiple scan	1,380 mm	2 x PNP (Q and /Q)	ELG6-1380P523
	2 x PNP (Q and /Q)			ELG6-1860P523	1025593
	2 x PNP (Q and /Q)			ELG6-2040P523	1025594
	2 x PNP (Q and /Q)			ELG6-2460P523	1024293

ELG6-Relay

- Beam separation: 60 mm

Working range	Evaluation beams	Detection height	Switching output	Model name	Part no.
12 m	Parallel beam	900 mm	Relay (DC 60 V, AC 25 V)	ELG6-0900R521	1026181
		1,860 mm	Relay (DC 60 V, AC 25 V)	ELG6-1860R521	1026182
		2,460 mm	Relay (DC 60 V, AC 25 V)	ELG6-2460R521	1026183
	Multiple scan	900 mm	Relay (DC 60 V, AC 25 V)	ELG6-0900R523	1025453
		1,380 mm	Relay (DC 60 V, AC 25 V)	ELG6-1380R523	1025451
		1,860 mm	Relay (DC 60 V, AC 25 V)	ELG6-1860R523	1026458

Type code

Beam separation

- 3 30 mm
- 6 60 mm

Detection height

- 0150 150 mm
- ...
- 2460 2,460 mm
- 3120 3,120 mm ¹⁾
- 3330 3,330 mm ¹⁾

Switching type

- N NPN (Q or /Q)
- P PNP (Q or /Q)
- R Relay
- V PNP (alarm or /Q) ¹⁾

Connection type

- 1 Cable 5 m ¹⁾
- 2 Cable 15 m ¹⁾
- 5 Connector M12

Working range, carrier frequency

- 2 12 m, IR 250 kHz (standard)
- 4 9 m, IR 500 kHz (rapid scan) ¹⁾
- 6 12 m, IR 313 kHz (beam coded)

Configuration

- 1 Standard (switching)
- 3 Cross beam (3-times)



¹⁾ On demand.

C

Dimensional drawings

ELG3/ELG6

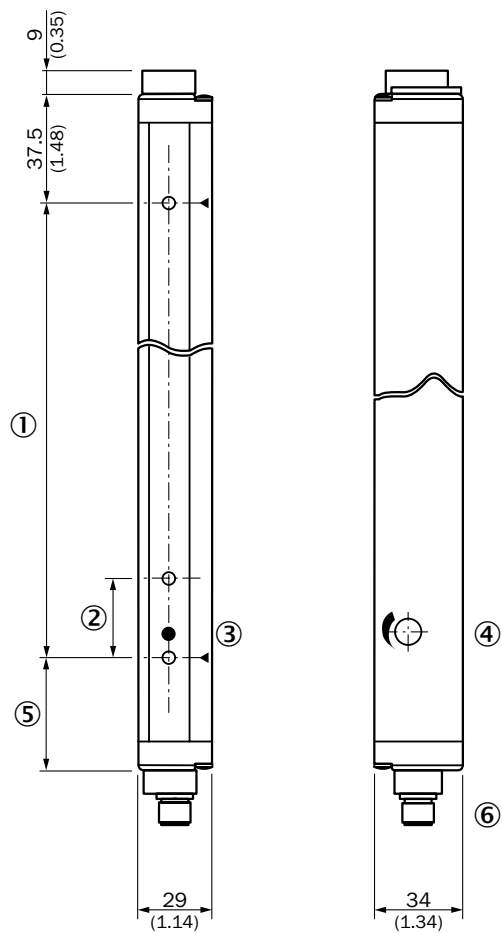

All dimensions in mm (inch)

- ① Detection height
- ② Beam separation ELG3: 30 mm/ELG6: 60 mm
- ③ Status indicator (ELGE)/power on (ELGS)
- ④ Sensitivity adjustment
- ⑤ Distance to first beam ELG3: 38.5 mm/ELG6: 68.5 mm
- ⑥ Connector M12, 4-pin

ELG3-Relay/ELG6-Relay

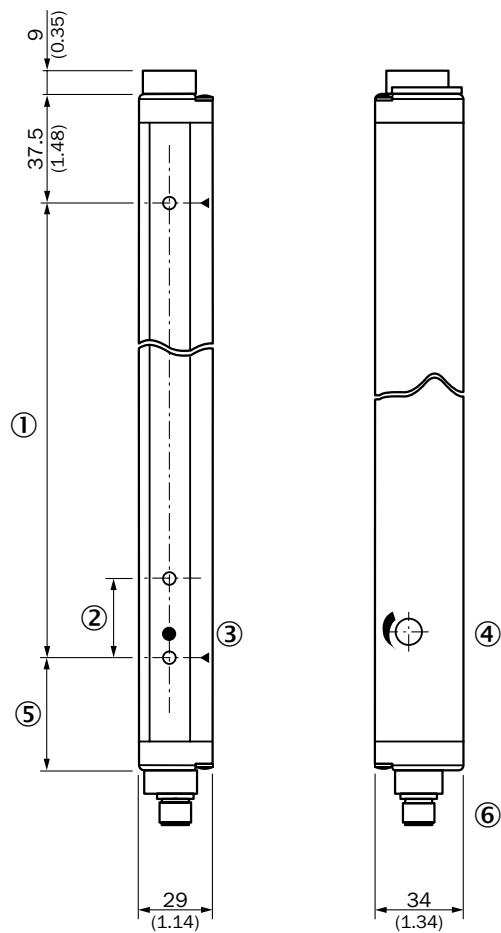

All dimensions in mm (inch)

- ① Detection height
- ② Beam separation ELG3: 30 mm/ELG6: 60 mm
- ③ Status indicator (ELGE)/power on (ELGS)
- ④ Sensitivity adjustment
- ⑤ Distance to first beam ELG3: 38.5 mm/ELG6: 68.5 mm
- ⑥ Connector M12, 5-pin

C

Adjustments

LED display sender

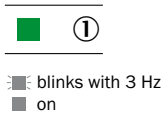
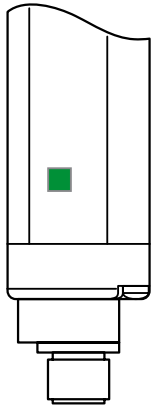

① Supply voltage

LED display receiver

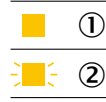
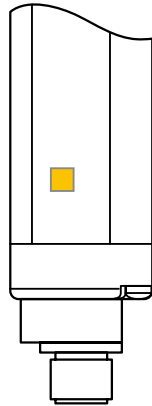

① No object in the light path
② Pollution indication

Connection type and diagram

ELG3/ELG6

Sender Connector
M12, 4-pin

Receiver Connector
M12, 4-pin

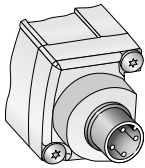
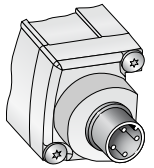

Sender

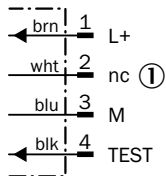

Receiver



- ① Not connected
- ② Change over
- ③ Normally open
- ④ Normally closed

ELG3-Relay

Sender Cable
4-pin

Receiver Cable
5-pin

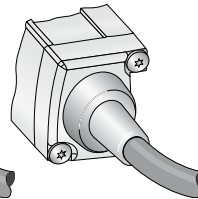
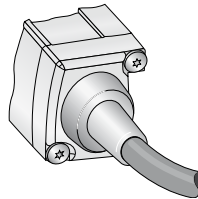

Sender

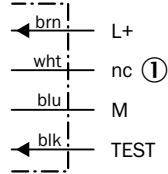

Receiver

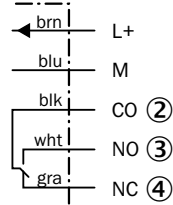

ELG3-Relay/ELG6-Relay

Sender Connector
M12, 4-pin

Receiver Connector
M12, 5-pin

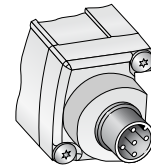
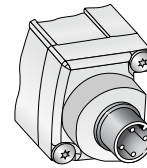

Sender

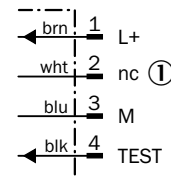

Receiver

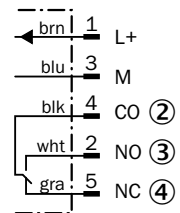



Recommended accessories

Complete accessories for the ELG Long Range include: 2 female connector cables and 1 bracket.

Please take note of the number of pins on the connector when choosing connection cables.

Mounting brackets/plates

	Brief description	Model name	Part no.
	Mounting kit 1, adjustable, swivel mount, for all detection heights in small housings, plastic, without mounting material, 4 pcs	BEF-2SMKEAKU4	2019649
	Mounting kit, side bracket including four sliding nuts for MLG/ELG/HLG, 4 pcs	BEF-NUT-MLG	2023696
	Mounting bracket, steel, zinc coated, without mounting material, 4 pcs	BEF-WK-XLG	2029100

Plug connectors and cables

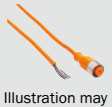
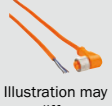
	Brief description	Model name	Part no.
 Illustration may differ	Female connector, M12, 4-pin, straight, 2 m, PVC	DOL-1204-G02M	6009382
	Female connector, M12, 4-pin, straight, 5 m, PVC	DOL-1204-G05M	6009866
	Female connector, M12, 4-pin, straight, 10 m, PVC	DOL-1204-G10M	6010543
	Female connector, M12, 4-pin, straight, 15 m, PVC	DOL-1204-G15M	6010753
 Illustration may differ	Female connector, M12, 4-pin, angled, 2 m, PVC	DOL-1204-W02M	6009383
	Female connector, M12, 4-pin, angled, 5 m, PVC	DOL-1204-W05M	6009867
	Female connector, M12, 4-pin, angled, 10 m, PVC	DOL-1204-W10M	6010541

For additional accessories including dimensional drawings, please see page E-8.

C

Special functions

Sensitivity adjustment

1. Remove cap

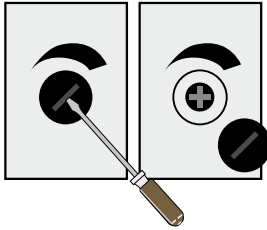

Remove cap with screw driver.

2. Potentiometer adjustment

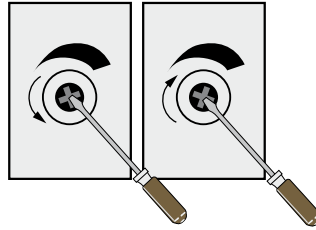

Turn left = for a lower range.
Turn right = for a higher range.

Sensitivity adjustment

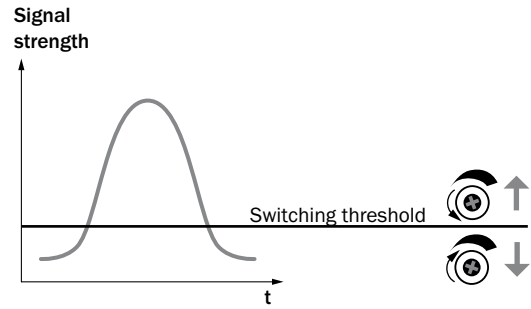

Optical synchronisation

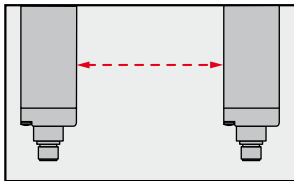

The light grid communicates via the light beams. A cable is not necessary for the optical synchronisation.

C

C

Simply clever order picking verification



Additional information

Detailed technical data. C-39
 Ordering information. C-40
 Dimensional drawing C-40
 Adjustments C-41
 Connection type and diagram . . . C-41
 Characteristic curve: range C-41
 Recommended accessories. C-42
 Special functions. C-43

Product description

Using sensors for order picking has become standard in the automotive and logistics industries. Using the PLG automation light grid for order picking offers significant advantages over conventional, manual order picking technology. The PLG is mounted at each storage bay and

has an integrated job LED to display pick position. The PLG's single-sided strip of reflective tape saves space in the bin and reduces damage and installation costs. Thanks to an integrated polarizing filter, the PLG won't be fooled by shiny or reflective clothing.

At a glance

- 360° visible job LED
- Range up to 2 m
- Flexible detection heights from 120 mm to 420 mm
- Immune to reflected and ambient light
- Switchable job LED: permanently lit or flashing
- Optically confirms the right bin was picked
- Bus connection possible

Your benefits

- The integrated job LED reduces the order picker's search time
- Low assembly costs thanks to the PLG's clever design
- High availability thanks to an integrated polarizing filter
- Tough aluminum housing ensures that sensor damage is kept to a minimum and helps reduce repair costs
- Reflective tape on the sensor avoids additional assembly and cabling costs

→ www.mysick.com/en/PLG3

C

Detailed technical data

Features

Technology	Retro-reflective light grid
Task	Switching light grid
Minimum detectable object (MDO)	Parallel beam: ≥ 35 mm
Number of beams	5 ... 15

Performance

Maximum range (reflective tape REF-PLG)	1.5 m
Maximum range (PL150)	2 m
Minimum range	≥ 100 mm
Working range (reflective tape REF-PLG)	1 m
Working range (PL150)	1.3 m
Response time ¹⁾	Parallel beam: > 100 ms

¹⁾ With resistive load.

Interfaces

Connection type	Short cable (0.28 m) with connector M12, 4-pin
Job LED input	PNP
Input current	12 mA

Mechanics/electronics

Wave length	650 nm
Supply voltage V_s ¹⁾	DC 15 V ... 30 V
Power consumption sender	< 45 mA
Ripple	$< 5 V_{PP}$
Output current I_{max}	100 mA
Output load capacitive	100 nF
Output load inductive	1 H
Initialization time	0.6 s
Dimensions (W x H x D)	35.6 mm x 199 mm x 19 mm ... 35.6 mm x 499 mm x 19 mm
Housing material	Aluminum
Indication	LED
Enclosure rating	IP 54
Circuit protection	V_s connections reverse-polarity protected Output Q short-circuit protected Interference suppression
Weight	200 g ... 500 g
Front screen	PMMA
Output mode ²⁾	Q dark switching
Current consumption job LED ¹⁾	10 mA

¹⁾ Typical values.

²⁾ Q = active in case one beam is interrupted; /Q = active in case all beams are free.

C

Ambient data

Protection class	III
EMC	EN 60947-5-2
Ambient temperature	Operation: -10 °C ... +55 °C Storage: -40 °C ... +70 °C
Vibration resistance	5 g, 10 Hz ... 55 Hz (IEC 68-2-6)
Shock load	10 g / DIN EN 60068-2-29 / 16 ms

Ordering information

Beam separation	Detection height	Switching output	Model name	Part no.
30 mm	120 mm	1 x PNP (Q)	PLG3-120F431	1028953
	210 mm	1 x PNP (Q)	PLG3-210F431	1028548
	270 mm	1 x PNP (Q)	PLG3-270F431	1029130
	360 mm	1 x PNP (Q)	PLG3-360F431	1029131
	420 mm	1 x PNP (Q)	PLG3-420F431	1029132

Dimensional drawing

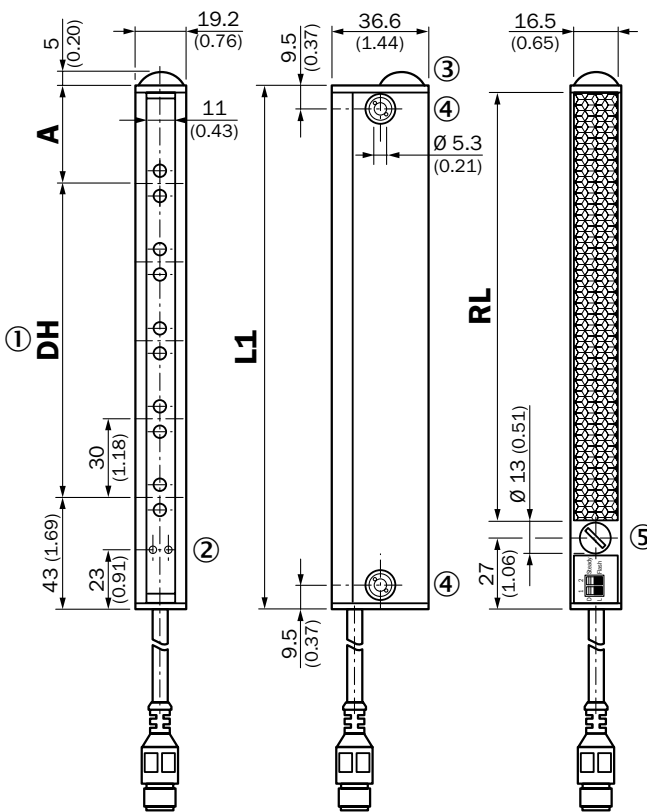

Dimensions in mm (inch)

DH	A	L1	RL
120 (4.72)	36 (1.42)	199 (7.83)	162 (6.38)
210 (8.27)	26 (1.02)	279 (10.98)	242 (9.53)
270 (10.63)	36 (1.42)	349 (13.74)	312 (12.28)
360 (14.17)	26 (1.02)	429 (16.89)	392 (15.43)
420 (16.54)	36 (1.42)	499 (19.65)	462 (18.19)

All dimensions in mm (inch)

- ① Detection height (DH) 120 to 420 mm
- ② Indicator power on: green; beam status: yellow
- ③ Job-LED, green
- ④ Mounting hole, Ø 5.3 mm
- ⑤ Configuration switches

Adjustments

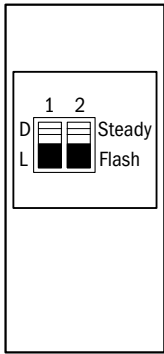

Configuration over switches

Switch 1	D	Output active, in case of blocked beams
	L	Output inactive, in case of blocked beams
Switch 2	Steady	Job-LED steady
	Flash	Job-LED flashes, 3 Hz

Connection type and diagram

Connector M12, 4-pin

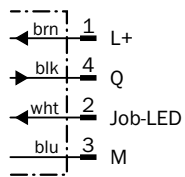
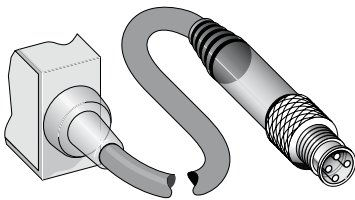

Characteristic curve: range

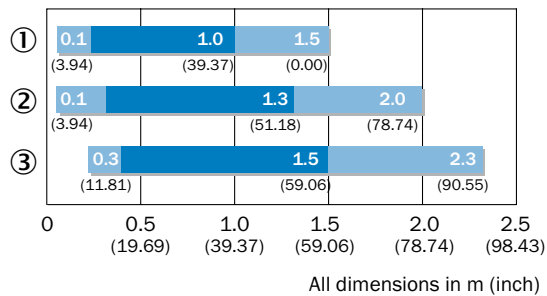



- ① REF-PLG
- ② PL150
- ③ PL180

Recommended accessories



Complete accessories for the PLG3 include: 1 female connector cable, 1 bracket and 1 reflector.

Please take note of the number of pins on the connector when choosing connection cables.

Mounting brackets/plates

	Brief description	Model name	Part no.
	Sliding nuts with spring metal sheet for Bosch profile, 2 x slot 8 and slot 10, including mounting material	BEF-NSBO-PLG	2041049
	Sliding nuts with spring metal ball for ITEM profile, 2 x slot 6 and slot 8, including mounting material	BEF-NSIT-PLG	2041045
	Round rod holder for round rods and tubes, including mounting material, 2 pcs	BEF-RD30-PLG	2040541

Reflectors

	Brief description	Model name	Part no.
	Reflector, 18 mm x 150 mm, plastic, self-adhesive	PL150	5315548
	Reflective tape on aluminum profile for PLG, 16.5 mm x 194.3 mm, 2-hole mounting	REF-PLG120	1029196
	Reflective tape on aluminum profile for PLG, 16.5 mm x 274.3 mm, 2-hole mounting	REF-PLG210	1029197
	Reflective tape on aluminum profile for PLG, 16.5 mm x 344.3 mm, 2-hole mounting	REF-PLG270	1029198
	Reflective tape on aluminum profile for PLG, 16.5 mm x 424.3 mm, 2-hole mounting	REF-PLG360	1029199
	Reflective tape on aluminum profile for PLG, 16.5 mm x 494.3 mm, 2-hole mounting	REF-PLG420	1029200

C

Plug connectors and cables

	Brief description	Model name	Part no.
 Illustration may differ	Female connector, M12, 4-pin, straight, 2 m, PVC	DOL-1204-G02M	6009382
	Female connector, M12, 4-pin, straight, 5 m, PVC	DOL-1204-G05M	6009866
	Female connector, M12, 4-pin, straight, 10 m, PVC	DOL-1204-G10M	6010543

For additional accessories including dimensional drawings, please see page E-8.

Special functions

Easy installation

1. Easy mounting on to different profiles

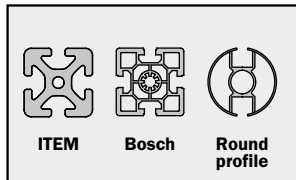

The light grid can be mounted on different profiles, e.g. ITEM, Bosch, round profile.

2. Easy installation with slot nuts



The PLG can easily be mounted on the profile with slot nuts.

Plug & play

1. Plug in and tighten the ring of the connector

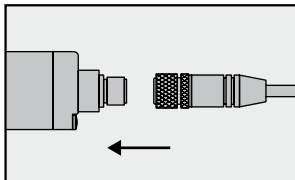

2. Device is ready for use

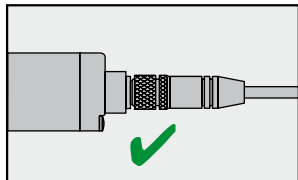
**C**

Increase pick rates in compact installations



C



Product description

Using sensors for order picking has become standard in the automotive and logistics industries. Using the PLG automation light grid for order picking offers significant advantages over conventional, manual order picking technology. The

PLG is mounted at each storage bay and has an integrated job LED to display pick position.

The PLG's single-sided strip of reflective tape saves space in the bin and reduces damage and installation costs.

At a glance

- 360° visible job LED
- Detection height 60 mm
- Optically confirms the right bin was picked
- Bus connection possible
- The smallest pick-to-light light grid

Your benefits

- The integrated job LED reduces the order picker's search time
- Low assembly costs thanks to the PLG's clever design
- Tough aluminum housing ensures that sensor damage is kept to a minimum and helps reduce repair costs
- Reflective tape on the sensor avoids additional assembly and cabling costs



Additional information

- Detailed technical data C-45
- Ordering information C-46
- Dimensional drawing C-46
- Connection type and diagram . . . C-47
- Recommended accessories C-47
- Special functions C-48

→ www.mysick.com/en/PLG6

Detailed technical data

Features

Technology	Retro-reflective light grid
Task	Switching light grid
Minimum detectable object (MDO)	Parallel beam: 70 mm
Number of beams	2

Performance

Maximum range	0.5 m
Minimum range	60 mm
Working range (reflective tape REF-PLG)	0.35 m
Response time ¹⁾	Parallel beam: 5 ms

¹⁾ With resistive load.

Interfaces

Connection type	Short cable (0.28 m) with connector M12, 4-pin
Job LED input	PNP
Input current	< 30 mA

Mechanics/electronics

Wave length	660 nm
Supply voltage V_s ¹⁾	DC 15 V ... 30 V
Power consumption sender	< 50 mA
Ripple	< 5 V_{pp}
Output current I_{max}	50 mA
Initialization time	< 1 s
Dimensions (W x H x D)	36.6 mm x 130 mm x 32 mm
Housing material	Aluminum
Indication	LED
Enclosure rating	IP 40
Circuit protection	V_s connections reverse-polarity protected Output Q short-circuit protected Interference suppression
Weight	< 500 g
Front screen	PMMA
Output mode ²⁾	Q dark switching
Current consumption job LED ¹⁾	< 30 mA

¹⁾ Typical values.

²⁾ Q = active in case one beam is interrupted; /Q = active in case all beams are free.

Ambient data

Protection class	III
EMC	EN 60947-5-2
Ambient temperature	Operation: -10 °C ... +50 °C Storage: -25 °C ... +70 °C
Vibration resistance	5 g, 10 Hz ... 55 Hz (IEC 68-2-6)
Shock load	10 g / DIN EN 60068-2-29 / 16 ms

Ordering information

Beam separation	Detection height	Switching output	Model name	Part no.
60 mm	60 mm	1 x PNP (Q)	PLG6-060F434	1051978

Dimensional drawing

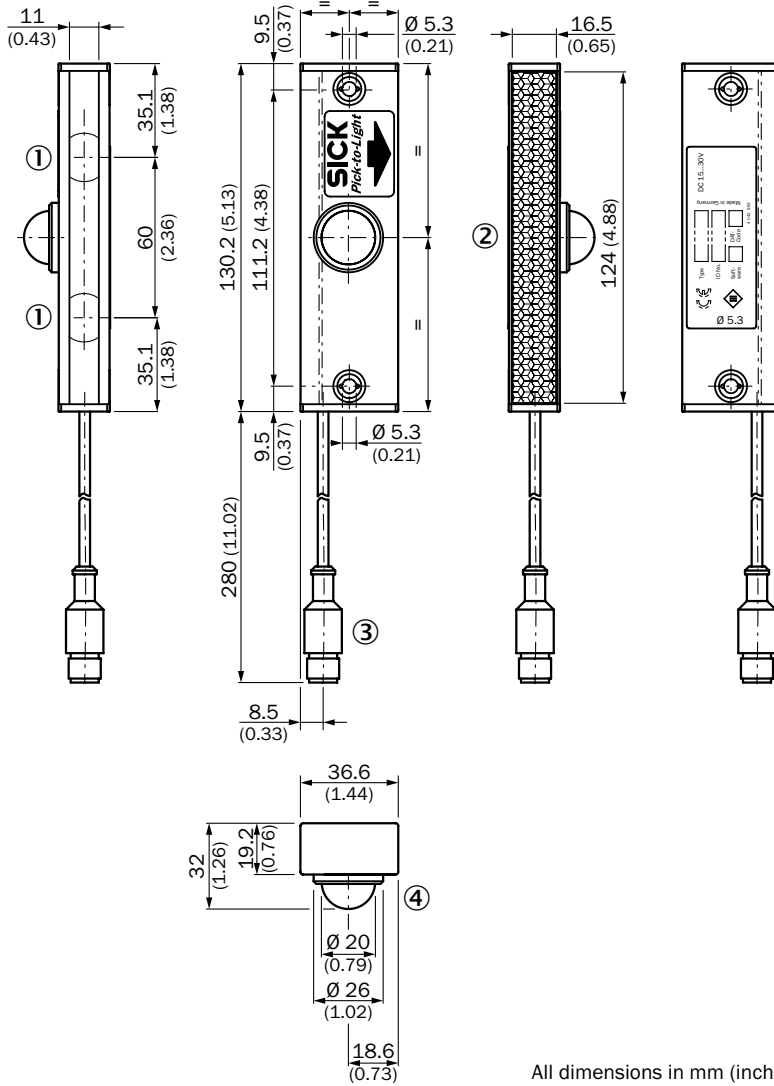

All dimensions in mm (inch)

- ① Reflection light barrier
- ② Reflective tape
- ③ Connector M12, 4-pin
- ④ Job LED, red

C

Connection type and diagram

Connector
M12, 4-pin

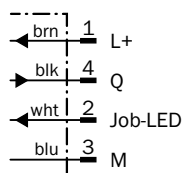
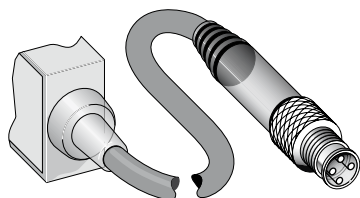

Recommended accessories

Complete accessories for the PLG6 include: 1 female connector cable, 1 bracket and 1 reflector.

Please take note of the number of pins on the connector when choosing connection cables.

Mounting brackets/plates

	Brief description	Model name	Part no.
	Sliding nuts with spring metal sheet for Bosch profile, 2x slot 8 and slot 10, including mounting material	BEF-NSBO-PLG	2041049
	Sliding nuts with spring metal ball for ITEM profile, 2x slot 6 and slot 8, including mounting material	BEF-NSIT-PLG	2041045
	Round rod holder for round rods and tubes, including mounting material, 2 pcs	BEF-RD30-PLG	2040541

Reflectors

	Brief description	Model name	Part no.
	Reflector, 18 mm x 150 mm, plastic, self-adhesive	PL150	5315548
	Reflective tape on aluminum profile for PLG, 16.5 mm x 194.3 mm, 2-hole mounting	REF-PLG060	1048996

Plug connectors and cables

	Brief description	Model name	Part no.
 Illustration may differ	Female connector, M12, 4-pin, straight, 2 m, PVC	DOL-1204-G02M	6009382
	Female connector, M12, 4-pin, straight, 5 m, PVC	DOL-1204-G05M	6009866
	Female connector, M12, 4-pin, straight, 10 m, PVC	DOL-1204-G10M	6010543

For additional accessories including dimensional drawings, please see page E-8.

Special functions

Easy installation

1. Easy mounting on to different profiles

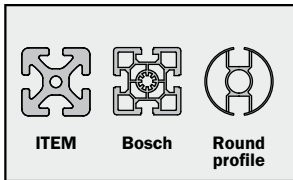

The light grid can be mounted on different profiles, e.g. ITEM, Bosch, round profile.

2. Easy installation with slot nuts



The PLG can easily be mounted on the profile with slot nuts.

Plug & play

1. Plug in and tighten the ring of the connector

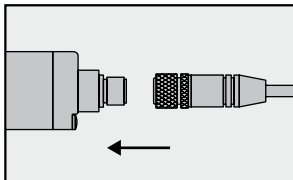

2. Device is ready for use

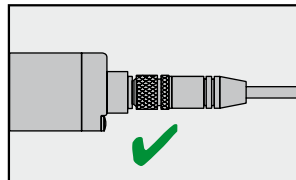

C

C



Smart, slender, stealth

The smart light grid family group includes smart area sensors, smart gate sensors and smart pick-to-light light grids. At only 8 mm x 25 mm, they fit nearly anywhere and can be imbedded inside walls, doors, conveyors, and machines. Slim and flat versions are available. They can be ordered in 120 to 1,400 mm lengths in a plastic or aluminum housing. Auto-muting, auto-teach and an alignment aid provide more uptime. They are ideal for order-picking, automatic doors, counting objects and other applications.

Your benefits

- Small, slim and sleek design enables easy integration into applications
- Capacitive teach-in button and LEDs make commissioning easier for complex solutions
- Slim and flat models offer flexible mounting options
- User-defined factory preset configuration or flexible configuration with teach-in button
- Optical synchronization eliminates the need to lay cables, saving time
- Stealth detection in public places – at only 8 mm x 25 mm, it fits just about anywhere and can be imbedded inside walls, doors, conveyors, and machines, reducing damage
- Auto-teach and auto-muting enable Plug & Play. And, an alignment aid and “Click & Go” provide faster installation.



D



Smart light grids

	Technology/applications	D-2
	Product family overview	D-6
	SAS Better machine control in a small housing	D-8
	SPL Error-proof picking	D-20
	SGS Opens the door to smart sensing	D-30

D

Whether slim, flat, short or long, nothing can get past smart light grids unnoticed



D

Smart light grids from SICK ensure nothing goes unnoticed and are available in range of variants for many types of applications. With a depth of just 8 mm and a width of 25 mm, various lengths and a choice of optical light exit, they are suitable for virtually all situations and can be integrated into walls, doors, conveyor belts, machines or shelves – from industrial gates to stocking small parts.

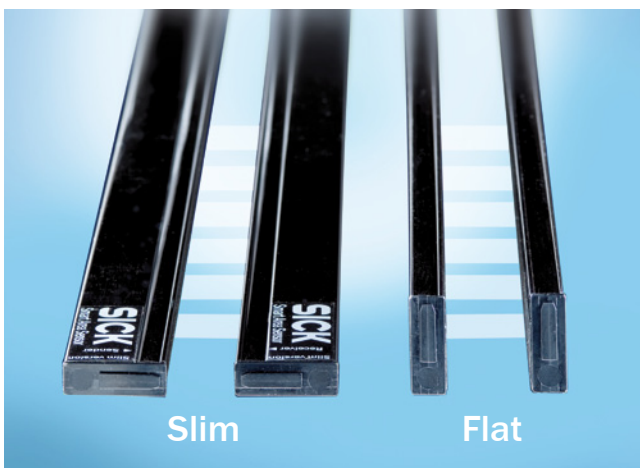

Slim

Flat

Slim & Flat – one housing profile, two options of optical light exit

Slim model = optical light exit on narrow side.

Flat model = optical light exit on wide side.



Short & long – it's your choice

Smart light grids from SICK are available in several lengths with various detection heights.

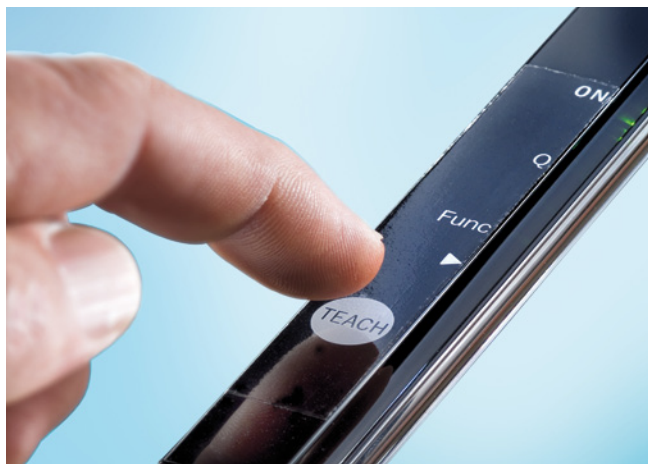

Plug & Play – and teachable versions available

Two options are available for maximum flexibility: set the range in the field with the clever teach button or choose a factory pre-configured option.



Click & Go – simple assembly concept

The “multi-connector” can be used to fasten smart light grids or for mechanical connection to another light grid. A specially developed aluminum housing makes mounting even easier.



LED indicator – visible indication of right or wrong

The integrated inspection unit with LEDs makes for easier commissioning, diagnostics and fault analysis – providing clear feedback for greater reliability.



Job LEDs – indicate not just where but precisely where

With the SPL smart pick-to-light light grid, individually switchable and 180°-visible green job LEDs are distributed across the entire detection height. For example when several components are located in one compartment stacked on top of one another, the light grids not only tell operators which compartment to reach into, but also indicate the height at which to do so.



The smart light grids (SLG) product family consists of the smart area sensor (SAS), smart gate sensor (SGS) and smart pick-to-light light grid (SPL) automation light grids.

Typical applications can be found on the following pages.

SPL – pick-to-light operator guidance



SAS – checking for overhang

D



SAS light grids are the perfect solution for numerous industrial automation tasks for and in machines. Their small size enables them to be used in virtually all situations, e.g. for checking overhang in the electronics industry.

Recommended product	SAS (see page D-8)
Limiting range	4 m
Resolution (beam separation)	40 mm
Detection height	120 mm ... 600 mm
Response time	< 20 ms

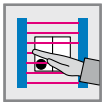

The SPL light grid provides effective support for picking in small parts racks since indicator and job LEDs are visible across its entire detection height. A window appears enabling you to immediately detect at a glance all the current removal compartments. A further benefit of the SPL is its integrated monitoring system for incorrect removals – as soon as a part is removed from a compartment which has not been indicated, the job LED will light up red. The SPL therefore makes a valuable contribution to quality assurance.

➔ For more information and other “pick-to-light” light grids by SICK, see page C-5.

Recommended product	SPL (see page D-20)
Limiting range	3 m
Resolution (beam separation)	40 mm
Detection height	120 mm ... 440 mm
Response time	< 20 ms

Selection guide

Light grid type	Chapter			Limiting range in m	Beam separation in mm	Detection height in mm	Job LED
PLG3	C-38						Green, visible from 360°
PLG6	C-44						Red, visible from 360°
SPL	D-20						Green, across entire light grid length at sender and receiver, visible from 180°

SGS – door/gate monitoring





Their large 10 m range and detection heights of up to 1.40 m mean SGS light grids by SICK are tried and tested in the widest applications such as monitoring of entrances and exits for vehicles at industrial sites. Their particularly narrow design enables them to be installed virtually invisibly for use as an innovative monitoring system at turnstiles in airports and train stations. Here, SGS light grids will ensure turnstiles do not close after the person has exited if objects are still located within the turnstile.







Recommended product	SGS (see page D-30)
Limiting range	10 m
Min. resolution (beam separation)	40 mm
Detection height	600 mm ... 1,400 mm
Response time	< 20 ms

Product family overview

	 <p style="text-align: center;">SAS</p>	
Better machine control in a small housing		
Technical data overview		
Beam separation	40 mm	
Working range	3 m	
Detection height	120 mm ... 600 mm	
Switching output	NPN PNP	
Optical light exit	Flat Slim	
Dimensions (W x H x D)	25 mm x 192.4 mm x 8 mm ... 25 mm x 672.4 mm x 8 mm	
At a glance		
	<ul style="list-style-type: none"> • Variable detection lengths from 120 mm up to 600 mm (in 160 mm increments) • Set parameters via teach-in with no PC • Simple teach-in setup • Maximum range 4 m • Response time 18 ms • 25 mm resolution with 40 mm beam separation possible • Highly immune to sunlight up to 150,000 lux • Small blind zone < 11 mm 	
Further information		
Applications		
Detailed information → D-8		

D

 <p>SPL</p>	 <p>SGS</p>
Error-proof picking	Opens the door to smart sensing
40 mm	40 mm 80 mm
1.5 m	3 m 7 m
120 mm ... 440 mm	600 mm ... 1,400 mm (SGS4) 560 mm ... 1,360 mm (SGS8)
NPN PNP	NPN / 2 x NPN PNP / 2 x PNP
Flat Slim	Flat Slim
25 mm x 192.4 mm x 8 mm ... 25 mm x 512.4 mm x 8 mm	25 mm x 672.4 mm x 8 mm ... 25 mm x 1,472.4 mm x 8 mm (SGS4) 25 mm x 932.4 mm x 8 mm ... 25 mm x 1,432.4 mm x 8 mm (SGS8)
<ul style="list-style-type: none"> • Variable detection lengths from 120 mm up to 440 mm • No commissioning necessary – Plug & Play operation • Maximum range 3 m • Response time 18 ms • 25 mm resolution with 40 mm beam separation possible • Highly visible job LEDs along the entire length of the sensor • Green job LEDs for correct pick and red job LEDs for incorrect pick • Can be connected to bus systems 	<ul style="list-style-type: none"> • Variable detection lengths from 560 mm up to 1,400 mm (in 160 mm increments) • Simple teach-in setup via cable • Optional parameter setting with teach-in button, no PC required • Maximum range 10 m • Response time 18 ms • 25 mm or 45 mm MDO possible • Highly immune to sunlight at 150,000 lux • Small blind zone < 11 mm
	
→ D-20	→ D-30

D

Better machine control in a small housing



Product description

The SAS light grid is an easy-to-install solution used on production, manufacturing, and fabricating machines. Thanks to its range of sizes, slim and sleek design, as well as special options the SAS light grids are ideal for a range of applications. The SAS is available in a flat and slim housing and is suitable

for detection heights from 120 mm to 600 mm. The software is accessed via an integrated teach-in button, offering the choice between parallel technology or even higher-resolution cross-beam technology. In addition, auto-muting, switching logic and an alignment aid provide more uptime.

At a glance

- Variable detection lengths from 120 mm up to 600 mm (in 160 mm increments)
- Set parameters via teach-in with no PC
- Simple teach-in setup
- Maximum range 4 m
- Response time 18 ms
- 25 mm resolution with 40 mm beam separation possible
- Highly immune to sunlight up to 150,000 lux
- Small blind zone < 11 mm

Your benefits

- Small, slim and sleek design enables easy integration into applications
- Capacitive teach-in button and LEDs make commissioning easier for complex solutions
- Slim and flat models offer flexible mounting options and optimize space while reducing damage
- Customized preset configurations or set parameters via one-touch teach-in with no PC
- Optical synchronization eliminates the need to lay cables, saving time
- Auto-teach and auto-muting enable Plug & Play. And, an alignment aid and “Click & Go” provide faster installation.



Additional information

Detailed technical data.....D-9

Ordering information.....D-10

Dimensional drawings.....D-13

Adjustments.....D-15

Connection type and diagram...D-15

Recommended accessories.....D-16

Special functions.....D-16

Setting the switching threshold via teaching process.....D-17

Configuration mode using the example of “cross beam/parallel beam”.....D-18

→ www.mysick.com/en/SAS

D

Detailed technical data

Features

Technology	Sender/receiver
Task	Switching light grid
Minimum detectable object (MDO)	Parallel beam: ≥ 45 mm Cross beam: ≥ 25 mm
Number of beams	4 ... 16
Configuration	Teach button with configuration software ¹⁾
Software features	Parallel beam Cross beam Output 1 high active/low active (normally open/closed), if light beam interrupted Automatic teach active/inactive With/without alignment aid

¹⁾ For all T-types (cf. type code).

Performance

Maximum range ¹⁾	4 m
Minimum range ²⁾	Parallel beam: ≥ 0 m Cross beam: ≥ 0.3 m
Response time	Parallel beam: 19 ms Cross beam: 57 ms

¹⁾ No reserve for environmental issue and deterioration of the diode.

²⁾ $\pm 10^\circ$.

Interfaces

Inputs	Teach input
Connection type	Short cable with connector M8, 4-pin

Mechanics/electronics

Wave length	IR, 950 nm
Supply voltage V_s	DC 24 V $\pm 20\%$
Power consumption sender ¹⁾	64 mA ... 136 mA
Power consumption receiver ¹⁾	70 mA
Ripple	$< 5 V_{pp}$
Output current I_{max}	100 mA
Output load capacitive	100 nF
Output load inductive	1 H
Initialization time	1 s
Dimensions (W x H x D)	25 mm x 192.4 mm x 8 mm ... 25 mm x 672.4 mm x 8 mm
Housing material	PMMA
Indication	LED
Synchronization	Optical
Enclosure rating	IP 65
Circuit protection	V_s connections reverse-polarity protected Output Q short-circuit protected Interference suppression
Weight	20 g ... 80 g
Switching frequency	500 kHz

¹⁾ Without load.

Ambient data

Protection class	III
EMC	EN 60947-5-2
Ambient temperature	Operation: -25 °C ... +55 °C Storage: -25 °C ... +70 °C
Ambient light safety ¹⁾	Direct: 100,000 lx Indirect: 150,000 lx
Vibration resistance	5 g, 10 Hz ... 55 Hz (IEC 68-2-6)
Shock load	10 g / DIN EN 60068-2-29 / 16 ms

¹⁾ Sunlight.

Specific data

Beam separation	Optical light exit	Aluminum stabilizer	Model name	Ordering information
40 mm	Flat	-	SAS4-Fxxxxxxx1xxx	D-10
		With stabilizer	SAS4-Fxxxxxxx2xxx	D-10
	Slim	-	SAS4-Sxxxxxxx1xxx	D-11
		With stabilizer	SAS4-Sxxxxxxx2xxx	D-11

Ordering information

The part numbers below show a selection of common configurations and represent only a portion of the product portfolio. The type code on page D-12 indicates all possible configurations that can be ordered.

Please note: Sender and receiver are only offered as a pair.

SAS4-Fxxxxxxx1xxx

- Beam separation: 40 mm
- Optical light exit: Flat
- Aluminum stabilizer: -

Working range	Detection height	Switching output	Model name	Part no.
3 m	120 mm	1 x NPN	SAS4-F012N3PS1T00	1208785
		1 x PNP	SAS4-F012P3PS1T00	1207475
			SAS4-F012P3PS1T01	1209637
		SAS4-F012P3PS1W00	1208450	
	280 mm	1 x NPN	SAS4-F028N3PS1T00	1208786
		1 x PNP	SAS4-F028P3PS1T00	1208171
	440 mm	1 x NPN	SAS4-F044N3PS1T00	1207761
		1 x PNP	SAS4-F044P3PS1T00	1045020
	600 mm	1 x NPN	SAS4-F060N3PS1T00	1208787
		1 x PNP	SAS4-F060P3PS1T00	1048058

SAS4-Fxxxxxxx2xxx

- Beam separation: 40 mm
- Optical light exit: Flat
- Aluminum stabilizer: With stabilizer

Working range	Detection height	Switching output	Model name	Part no.
3 m	280 mm	1 x PNP	SAS4-F028P3PS2T00	1207711
	600 mm	1 x PNP	SAS4-F060P3PS2T00	1209213

SAS4-Sxxxxxxx1xxx

- **Beam separation:** 40 mm
- **Optical light exit:** Slim
- **Aluminum stabilizer:** -

Working range	Detection height	Switching output	Model name	Part no.
3 m	120 mm	1 x NPN	SAS4-S012N3PS1T00	1047009
			SAS4-S012N3PS1W00	1047014
	280 mm	1 x PNP	SAS4-S012P3PS1T00	1047364
			SAS4-S028N3PS1T00	1207707
	440 mm	1 x NPN	SAS4-S028N3PS1W00	1207704
			SAS4-S028P3PS1T00	1047063
		1 x PNP	SAS4-S044N3PS1T0D	1209170
			SAS4-S044N3PS1T00	1207708
	600 mm	1 x NPN	SAS4-S044N3PS1W00	1207705
			SAS4-S044P3PS1T00	1045019
			SAS4-S044P3PS1W00	1209581
		1 x PNP	SAS4-S060N3PS1T0D	1209171
			SAS4-S060N3PS1T00	1207709
			SAS4-S060N3PS1W00	1207706
	1 x PNP	SAS4-S060N3PS1W02	1207752	
		SAS4-S060P3PS1T00	1047587	
SAS4-S060P3PS1W00	1047525			

SAS4-Sxxxxxxx2xxx

- **Beam separation:** 40 mm
- **Optical light exit:** Slim
- **Aluminum stabilizer:** With stabilizer

Working range	Detection height	Switching output	Model name	Part no.
3 m	120 mm	1 x PNP	SAS4-S012P3PS2W04	1208464
	600 mm	1 x PNP	SAS4-S060P3PS2W0A	1209013



Type code

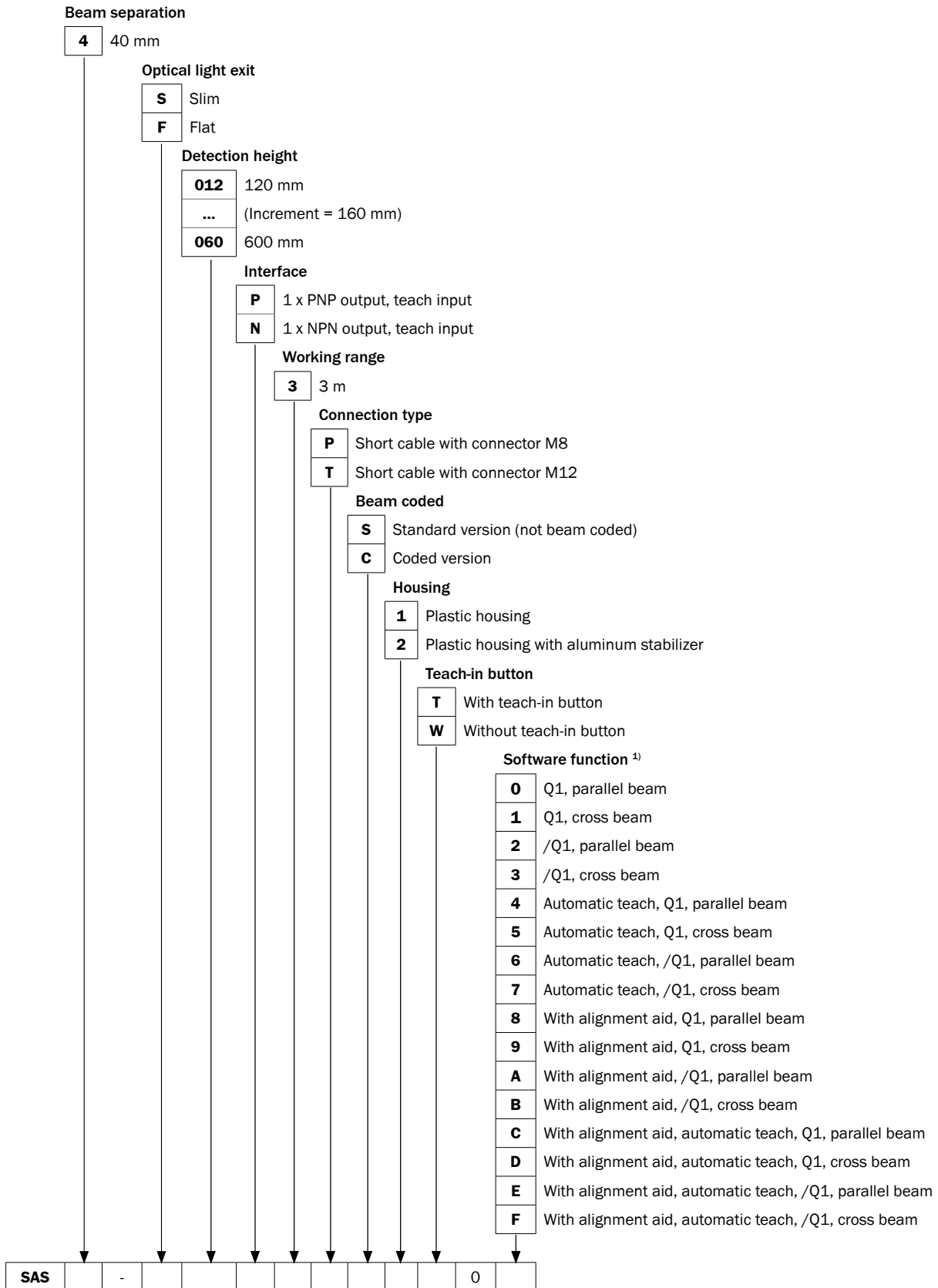

D

¹⁾ Alignment aid = LEDs signalize the correct alignment ; Automatic teach = automatic teach at plug-in
 Q1 = switching status ON if light path interrupted ; /Q1; /Q2 = switching status OFF if light path interrupted.

Dimensional drawings

SAS4-Fxxxxxx1xxx

Flat, without stabilizer

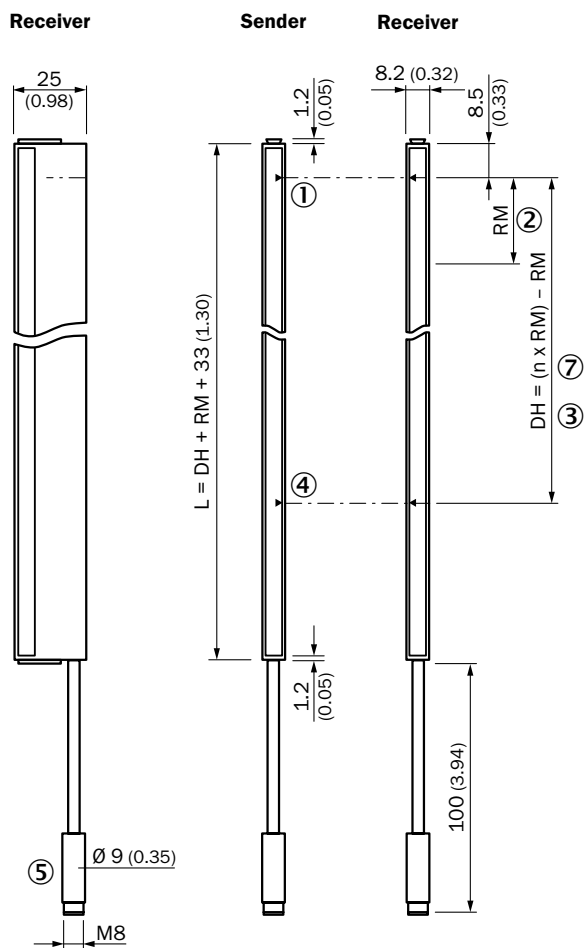

All dimensions in mm (inch)

SAS4-Fxxxxxx2xxx

Flat, with stabilizer

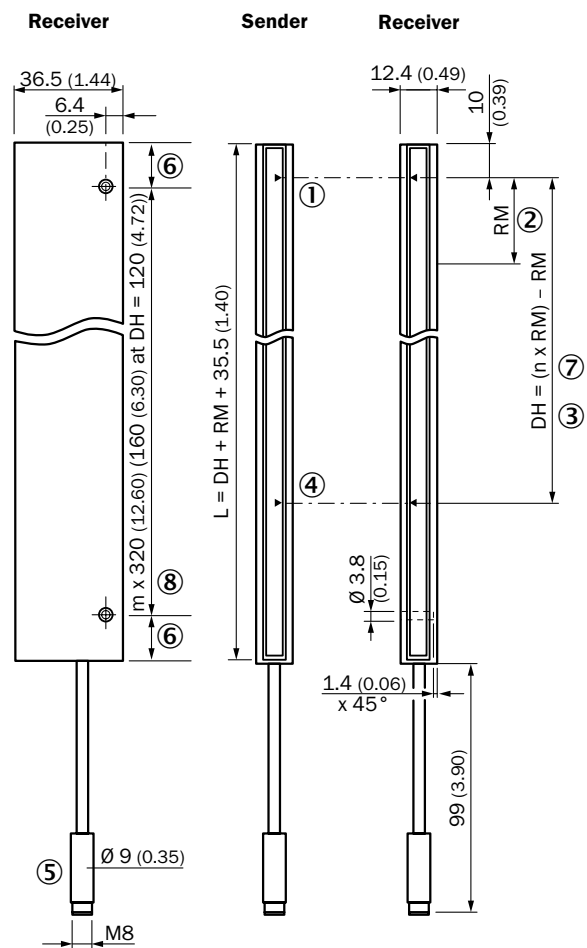

All dimensions in mm (inch)

- ① Last beam
- ② Beam separation RM
- ③ DH - Detection height (n x 40 mm) - RM
- ④ First beam
- ⑤ Connection
- ⑥ Same distance
- ⑦ n = beam
- ⑧ m = mounting hole



SAS4-Sxxxxxxx1xxx
Slim, without stabilizer

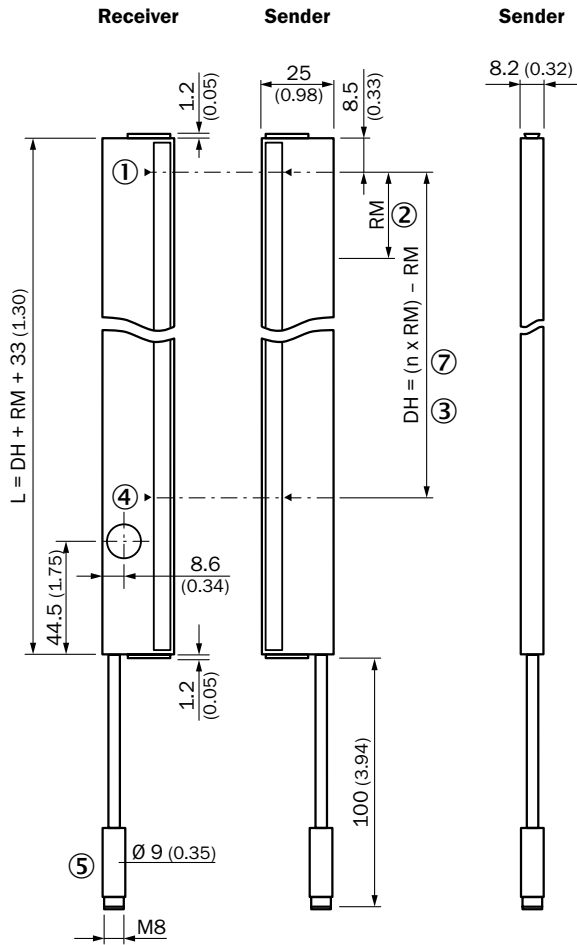

All dimensions in mm (inch)

SAS4-Sxxxxxxx2xxx
Slim, with stabilizer

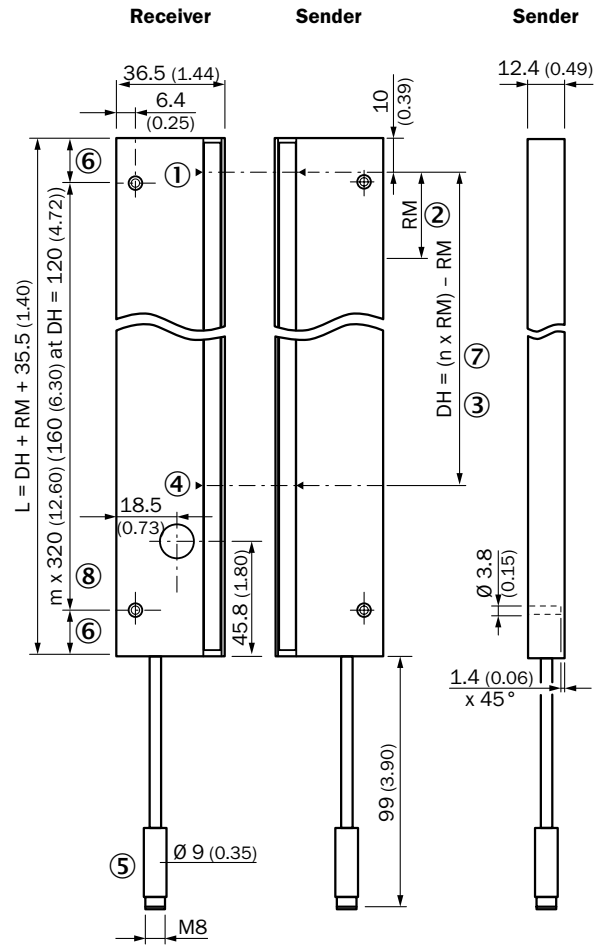

All dimensions in mm (inch)

D

- ① Last beam
- ② Beam separation RM
- ③ DH - Detection height (n x 40 mm) - RM
- ④ First beam
- ⑤ Connection
- ⑥ Same distance
- ⑦ n = beam
- ⑧ m = mounting hole

Adjustments

Receiver, LED indication

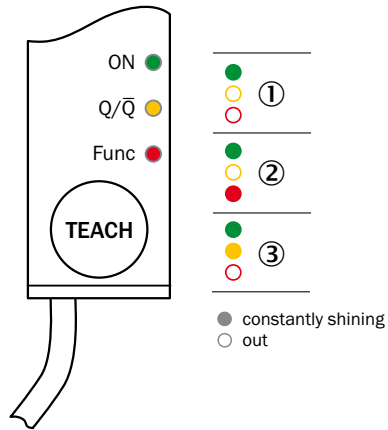

- ① Supply voltage
- ② Active, if teach-in button is pressed
- ③ No object in the light path

Connection type and diagram

**Sender
Connector
M8, 4-pin**

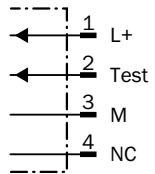
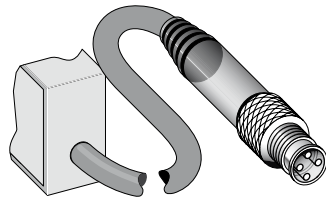

**Receiver
Connector
M8, 4-pin**

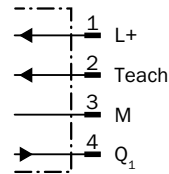
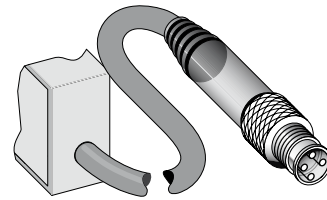

D

Recommended accessories



Complete accessories for SAS include: 2 female connector cables and 1 bracket.

Please take note of the number of pins on the connector when choosing connection cables.

Terminal and alignment brackets

	Brief description	Model name	Part no.
	Mounting bracket for mounting on the top sides. The mounting kit consists of 4 x BEF-SLG1.	BEF-SLG-SET2	2056518

Plug connectors and cables

	Brief description	Model name	Part no.
 Illustration may differ	Female connector, M8, 4-pin, straight, 2 m, PVC	DOL-0804-G02M	6009870
	Female connector, M8, 4-pin, straight, 5 m, PVC	DOL-0804-G05M	6009872
	Female connector, M8, 4-pin, straight, 10 m, PVC	DOL-0804-G10M	6010754
 Illustration may differ	Female connector, M12, 4-pin, straight, 2 m, PVC	DOL-1204-G02M	6009382
	Female connector, M12, 4-pin, straight, 5 m, PVC	DOL-1204-G05M	6009866
	Female connector, M12, 4-pin, straight, 10 m, PVC	DOL-1204-G10M	6010543

For additional accessories including dimensional drawings, please see page E-14.

Special functions

Optical synchronisation

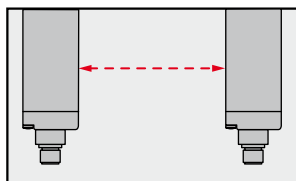

D

The light grid communicates via the light beams. A cable is not necessary for the optical synchronisation.

Setting the switching threshold via teaching process

1. Light grid in RUN mode, green LED "ON" illuminates, yellow LED "Q" illuminates.

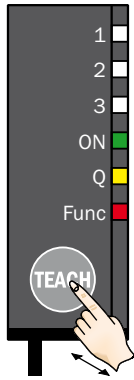

1 s ... 5 s

Press the teach button for 1 s to 5 s. During the teach process the green LEDs illuminates sequentially. The red LED "Func" illuminates.

2. Alignment aid is automatically activated for 10 s.

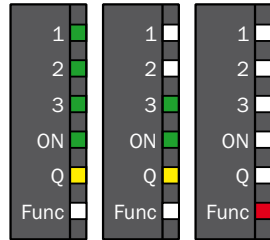

① ② ③

- ① = Optimum light reception.
- ② = Light reception not optimized,
→ **align sensors.**
- ③ = No light received,
→ **check light path.**

The light grid switches after 10 s automatically back into the RUN mode.

3. Light grid in RUN mode, green LED "ON" illuminates, yellow LED "Q" illuminates.



The switching threshold is set.

Configuration mode using the example of “cross beam/parallel beam”

If the teach button is pressed longer than 5 s, you switch into the configuration mode. In the configuration mode the menu items are indicated by the green LEDs. If the teach button is then pressed for < 1 s, the respective function is activated or reset (yellow LED on or off). If the teach button is pressed for 1 s to 5 s long, you switch to the next menu item. To exit the configuration mode, press the teach button for > 5 s or wait for 30 s.

1. Light grid in RUN mode, green LED “ON” illuminates, yellow LED “Q” illuminates.

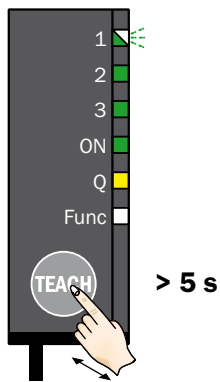

2. Cross or parallel beam set up.¹⁾

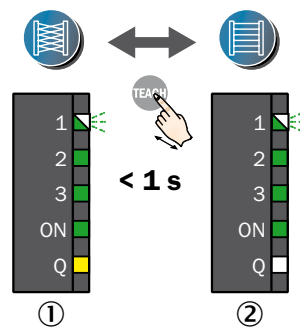

3. Go to the next menu item.

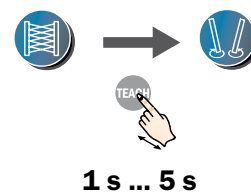

4. Exit the configuration mode.

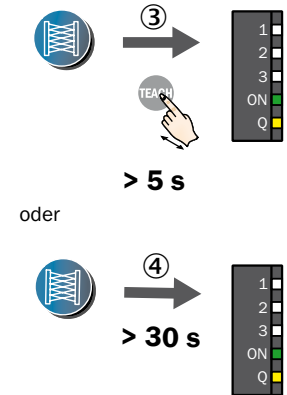

Press teach button > 5 s. The light grid switches into the configuration mode – menu item “cross beam/parallel beam”. The first green LED from top flashes.

- ① = Yellow LED on, → “Crossed beam” active.
- ② = Yellow LED off, → “Parallel beam” active.

Press teach button for 1 s to 5 s to switch to the next menu item (in this case “alignment aid”).

- ③ = Press teach button > 5 s, → save parameters.
- ④ = Wait > 30 s, → parameters not saved.

Press teach button < 1 s to switch between the settings.

¹⁾ Configure the light grid in a 3-way cross-beam or a parallel-oriented operating principle. The cross beam can be used to improve the resolution in the middle detection area. Objects up to a size of 25 mm can be detected. The response time increases.

D

The other menu items in sequence of the menu setting of the light grid

Alignment aid ²⁾	Invert switching output	Auto-teach ³⁾	Pushbutton lock	Standard values ⁴⁾
active	Q ₁	active	active	active
inactive	$\overline{Q_1}$	inactive	inactive	inactive

²⁾ The alignment aid is recommended for applications with high ranges. The signal strength of the receiver is permanently displayed by four green alignment LEDs. Depending on the strength, the number of illuminated LEDs differ. When reception is strong, all four LEDs illuminate. The alignment aid must be deactivated again after alignment.

³⁾ After commissioning (power on), the switching threshold is taught in automatically. No object should be between the sender and receiver during this process.

⁴⁾ With standard values “active” all parameters are reset to the delivery state.

D

Error-proof picking



Product description

The SPL pick-to-light light grid from SICK ensures optimum picking accuracy, reducing errors and improving quality. The SPL is an operator-friendly light grid – the ergonomic and economical solution for access control and picking control. The green job LEDs indicate the correct picking bin to the operator and optically confirms that the correct

item has been picked. The red LED lights when there is a picking error. This means no wrong components are used, no missing parts and no rework. In addition, features such as auto-muting, auto-teach, and an alignment aid provide more uptime. The SPL ensures process reliability and quality.

At a glance

- Variable detection lengths from 120 mm up to 440 mm
- No commissioning necessary – Plug & Play operation
- Maximum range 3 m
- Response time 18 ms
- 25 mm resolution with 40 mm beam separation possible
- Highly visible job LEDs along the entire length of the sensor
- Green job LEDs for correct pick and red job LEDs for incorrect pick
- Can be connected to bus systems

Your benefits

- Highly visible job LEDs can be seen from any position
- Picking error display for order picking improves quality
- Plug & Play operation saves time
- Automatic teach-in when turned on
- Slim and flat models offer flexible mounting options and optimize shelf/bin space while reducing damage
- Quick, cost-effective installation thanks to optical synchronization – no need to wire the sender and receiver together
- Auto-muting, auto-teach and an alignment aid provide more uptime



Additional information

Detailed technical dataD-21

Ordering informationD-22

Dimensional drawingsD-25

AdjustmentsD-27

Connection type and diagram . . .D-27

Recommended accessoriesD-28

Special functionsD-29

→ www.mysick.com/en/SPL

D

Detailed technical data

Features

Technology	Sender/receiver
Task	Switching light grid
Minimum detectable object (MDO)	Parallel beam: ≥ 45 mm Cross beam: ≥ 25 mm
Number of beams	4 ... 12
Configuration	Without teach button with configuration software
Software features	Parallel beam Cross beam Output 1 high active/low active (normally open/closed), if light beam interrupted Automatic teach active/inactive With/without alignment aid

Performance

Maximum range ¹⁾	3 m
Minimum range ²⁾	Parallel beam: ≥ 0 m Cross beam: $\geq 0,3$ m
Response time	Parallel beam: 19 ms Cross beam: 57 ms

¹⁾ No reserve for environmental issue and deterioration of the diode.

²⁾ $\pm 10^\circ$.

Interfaces

Inputs	Job LED
Connection type	Short cable with connector M8, 4-pin

Mechanics/electronics

Wave length	IR, 950 nm
Supply voltage V_s	DC 24 V ± 20 %
Power consumption sender ¹⁾	50 mA
Power consumption receiver ¹⁾	50 mA
Ripple	$< 5 V_{PP}$
Output current I_{max}	100 mA
Output load capacitive	100 nF
Output load inductive	1 H
Initialization time	1 s
Dimensions (W x H x D)	25 mm x 192.4 mm x 8 mm ... 25 mm x 512.4 mm x 8 mm
Housing material	PMMA
Indication	LED
Synchronization	Optical
Enclosure rating	IP 65
Circuit protection	V_s connections reverse-polarity protected Output Q short-circuit protected Interference suppression
Weight	20 g ... 60 g
Switching frequency ²⁾	500 kHz 250 kHz

¹⁾ Without load.

²⁾ Depending on type.

Ambient data

Protection class	III
EMC	EN 60947-5-2
Ambient temperature	Operation: -25 °C ... +55 °C Storage: -25 °C ... +70 °C
Ambient light safety ¹⁾	Direct: 100,000 lx Indirect: 150,000 lx
Vibration resistance	5 g, 10 Hz ... 55 Hz (IEC 68-2-6)
Shock load	10 g / DIN EN 60068-2-29 / 16 ms

¹⁾ Sunlight.

Specific data

Beam separation	Optical light exit	Aluminum stabilizer	Model name	Ordering information
40 mm	Flat	-	SPL-Fxxxxxx1xxx	D-22
		With stabilizer	SPL-Fxxxxxx2xxx	D-22
	Slim	-	SPL-Sxxxxxx1xxx	D-23
		With stabilizer	SPL-Sxxxxxx2xxx	D-23

Ordering information

The part numbers below show a selection of common configurations and represent only a portion of the product portfolio. The type code on page D-24 indicates all possible configurations that can be ordered.

Please note: Sender and receiver are only offered as a pair.

SPL-Fxxxxxx1xxx

- Beam separation: 40 mm
- Optical light exit: Flat
- Aluminum stabilizer: -

Working range	Detection height	Switching output	Model name	Part no.
1.5 m	120 mm	1 x NPN	SPL-F120NPS1W04	1208550
		1 x PNP	SPL-F120PPC1W04	1208391
	280 mm	1 x PNP	SPL-F120PPS1W04	1046128
		1 x PNP	SPL-F280PPS1W04	1046764
		1 x PNP	SPL-F440PPS1W04	1046314

SPL-Fxxxxxx2xxx

- Beam separation: 40 mm
- Optical light exit: Flat
- Aluminum stabilizer: With stabilizer

Working range	Detection height	Switching output	Model name	Part no.
1.5 m	120 mm	1 x PNP	SPL-F120PPS2W04	1047344
	280 mm	1 x PNP	SPL-F280PPS2W04	1046996

SPL-Sxxxxx1xxx

- **Beam separation:** 40 mm
- **Optical light exit:** Slim
- **Aluminum stabilizer:** -

Working range	Detection height	Switching output	Model name	Part no.
1.5 m	120 mm	1 x PNP	SPL-S120PPS1W04	1046127
	280 mm	1 x PNP	SPL-S280PPS1W04	1046763
	440 mm	1 x NPN	SPL-S440NPS1W04	1047365
		1 x PNP	SPL-S440PPS1W04	1046312

SPL-Sxxxxx2xxx

- **Beam separation:** 40 mm
- **Optical light exit:** Slim
- **Aluminum stabilizer:** With stabilizer

Working range	Detection height	Switching output	Model name	Part no.
1.5 m	280 mm	1 x PNP	SPL-S280PPS2W04	1209197
	440 mm	1 x PNP	SPL-S440PPS2W04	1045018

Type code

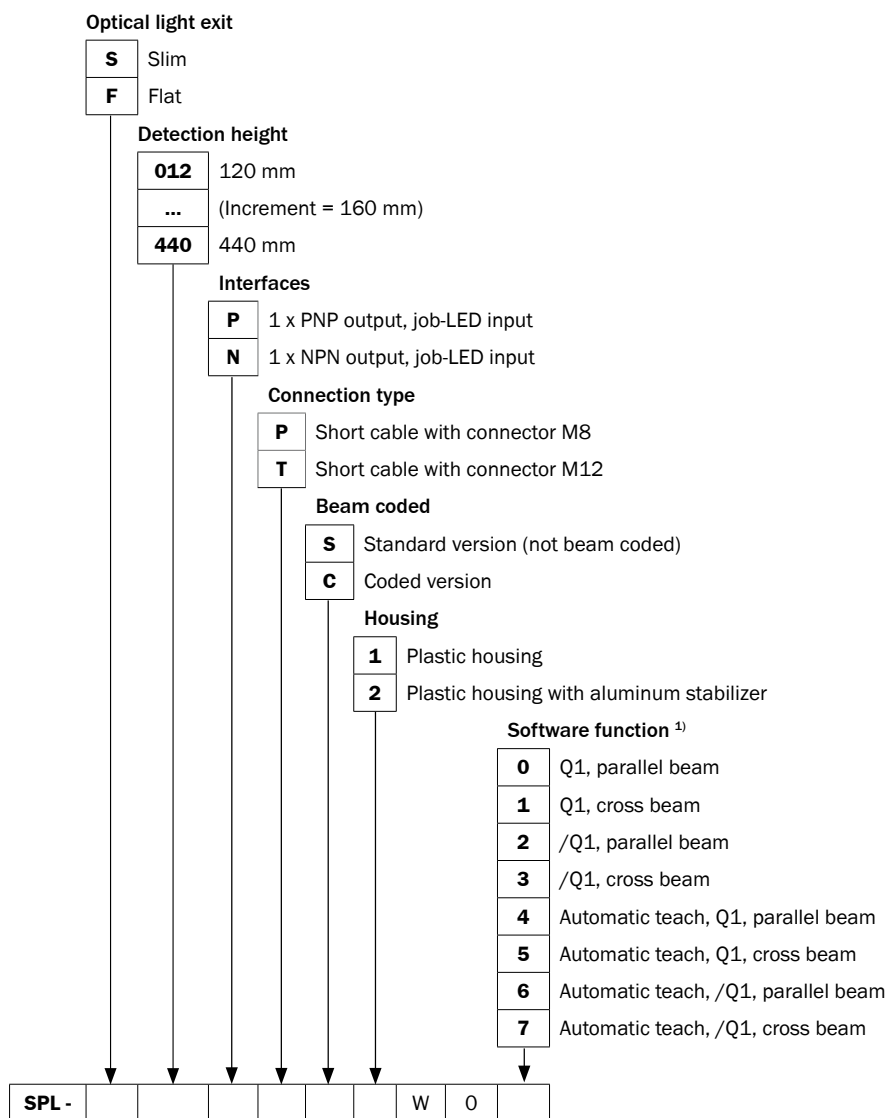

¹⁾ Software functions can only be ordered pre-configured:
 Automatic teach = automatic teach at plug-in
 Q1 = switching status ON if light path interrupted
 /Q1 = switching status OFF if light path interrupted

D

Dimensional drawings

SPL-Fxxxxx1xxx

Flat, without stabilizer

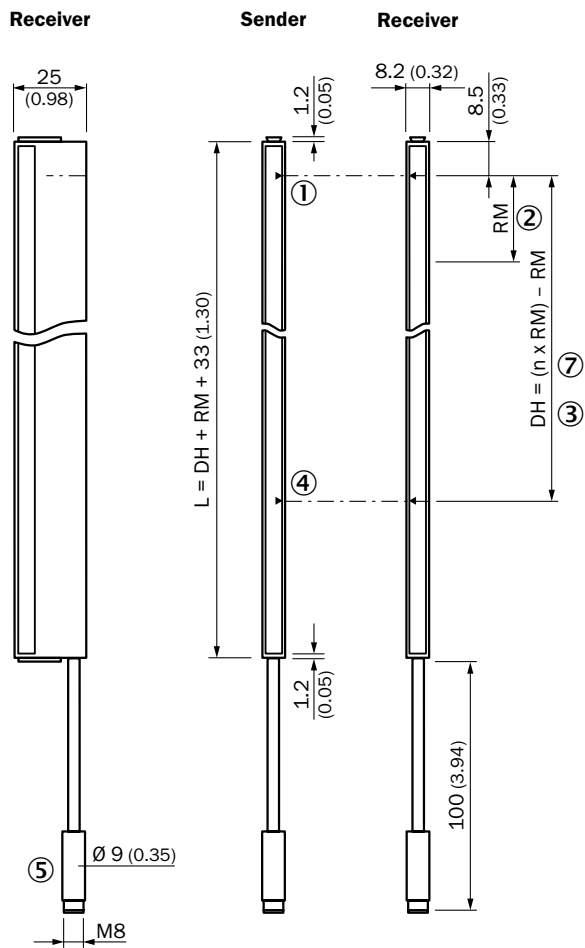

All dimensions in mm (inch)

SPL-Fxxxxx2xxx

Flat, with stabilizer

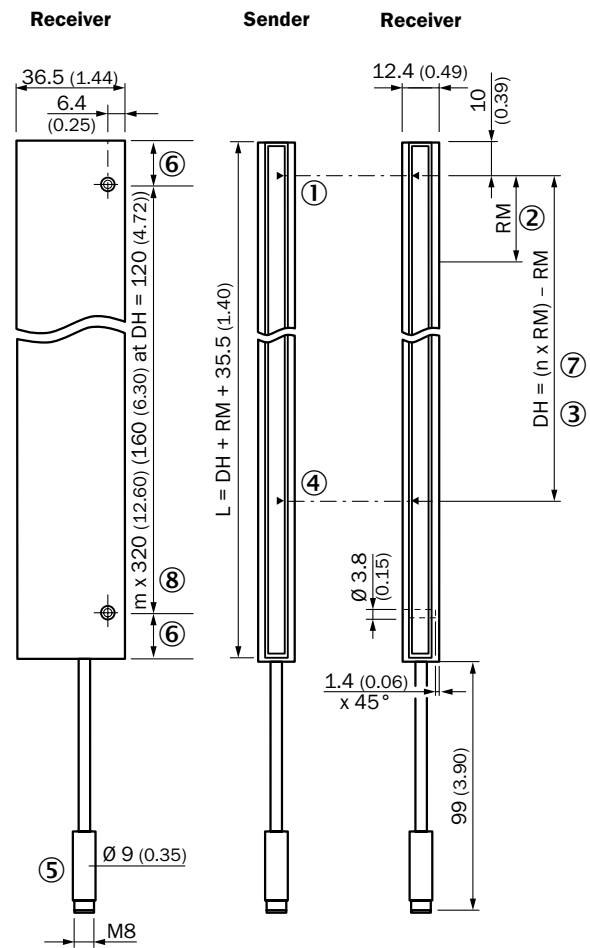

All dimensions in mm (inch)

- ① Last beam
- ② Beam separation RM
- ③ DH - Detection height (n x 40 mm) - RM
- ④ First beam
- ⑤ Connection
- ⑥ Same distance
- ⑦ n = beam
- ⑧ m = mounting hole



SPL-Sxxxxxx1xxx

Slim, without stabilizer

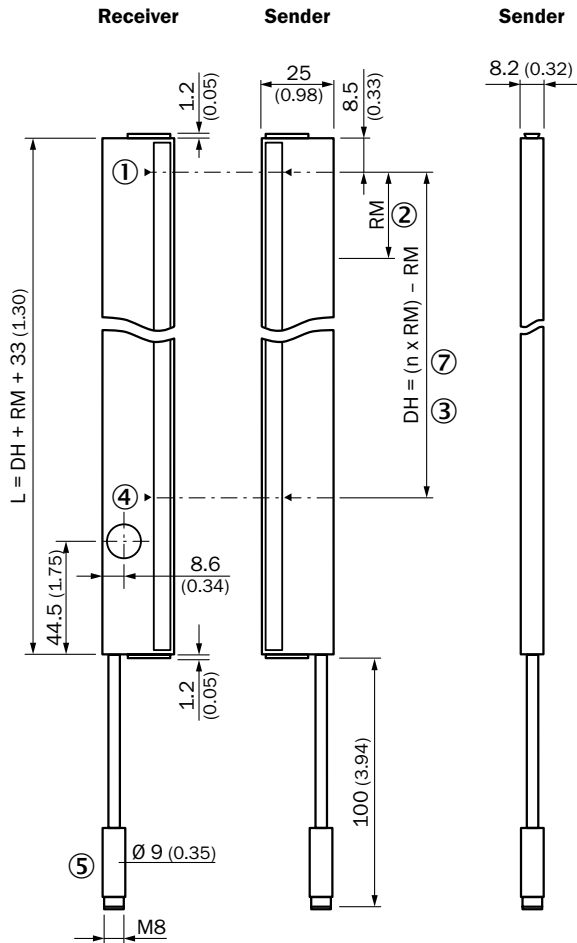

All dimensions in mm (inch)

SPL-Sxxxxxx2xxx

Slim, with stabilizer

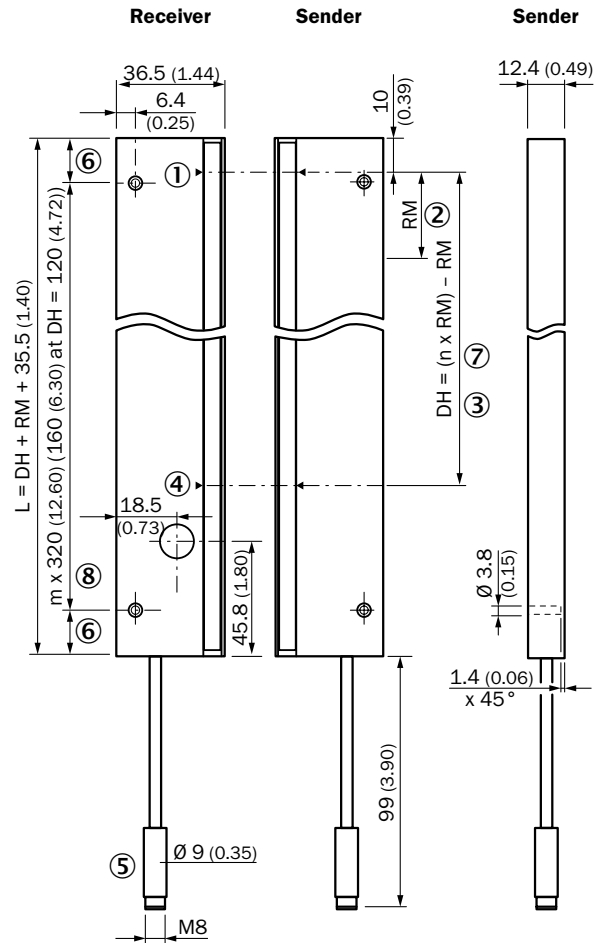

All dimensions in mm (inch)

D

- ① Last beam
- ② Beam separation RM
- ③ DH - Detection height (n x 40 mm) - RM
- ④ First beam
- ⑤ Connection
- ⑥ Same distance
- ⑦ n = beam
- ⑧ m = mounting hole

Adjustments

Receiver, LED indication

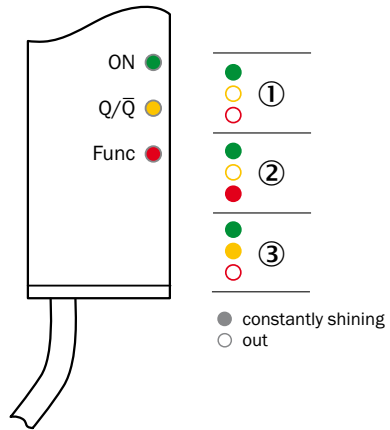

- ① Supply voltage
- ② Active, if teach procedure active
- ③ No object in the light path

Connection type and diagram

**Sender
Connector
M8, 4-pin**

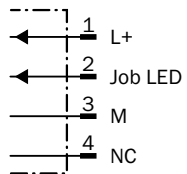
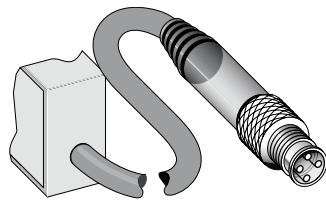

**Receiver
Connector
M8, 4-pin**

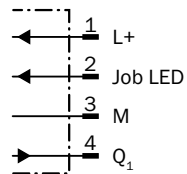
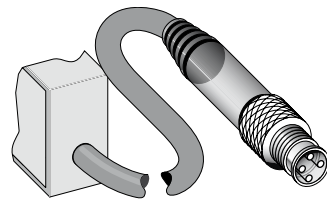



D

Recommended accessories

Complete accessories for SPL include: 2 female connector cables and 1 bracket.

Please take note of the number of pins on the connector when choosing connection cables.



Adapters/distributors (without cable)

	Brief description	Model name	Part no.
	Sensor/actuator box, 4 x M12, 5-pin, cable, 5 m, PUR halogen free	SBL-04D12-KC05	6028394
	Sensor/actuator box, 8 x M12, 5-pin, cable, 5 m, PUR halogen free	SBL-08D12-KC05	6028396

Terminal and alignment brackets

	Brief description	Model name	Part no.
	Mounting bracket for mounting on the top sides. The mounting kit consists of 4 x BEF-SLG1.	BEF-SLG-SET2	2056518

Plug connectors and cables

	Brief description	Model name	Part no.
 Illustration may differ	Female connector, M8, 4-pin, straight, 2 m, PVC	DOL-0804-G02M	6009870
	Female connector, M8, 4-pin, straight, 5 m, PVC	DOL-0804-G05M	6009872
	Female connector, M8, 4-pin, straight, 10 m, PVC	DOL-0804-G10M	6010754
 Illustration may differ	Female connector, M12, 4-pin, straight, 2 m, PVC	DOL-1204-G02M	6009382
	Female connector, M12, 4-pin, straight, 5 m, PVC	DOL-1204-G05M	6009866
	Female connector, M12, 4-pin, straight, 10 m, PVC	DOL-1204-G10M	6010543

For additional accessories including dimensional drawings, please see page E-14.

Special functions

Optical synchronisation

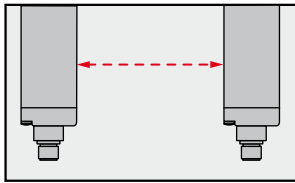

The light grid communicates via the light beams. A cable is not necessary for the optical synchronisation.

Plug & Play

1. Plug in and tighten the ring of the connector

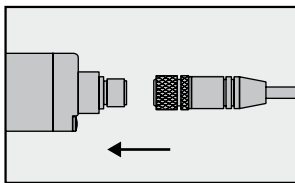

2. Device is ready for use

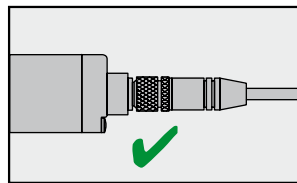

Job-LED

1. Object picking from the indicated bin

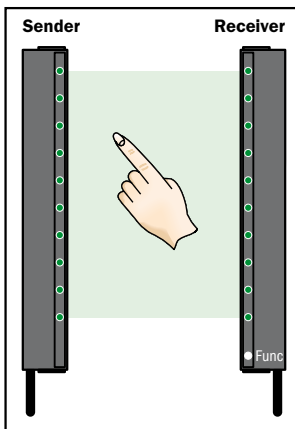

2. Incorrect picking

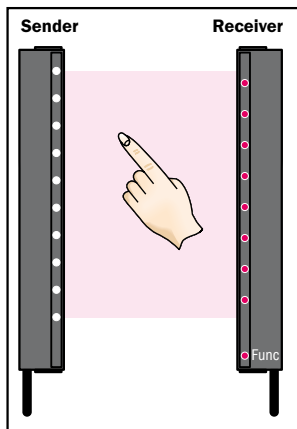

The “green” Job LEDs indicate the correct picking bin to the operator and confirm optically that the correct picking has taken place.

The “red” Job LEDs light in case of picking errors. The function LED “Func” will also turn “red” to indicate a picking error.

Opens the door to smart sensing



Product description

SGS can be mounted inside doors, gates, and entry/exit points. As a result, they are the largest light grids of the SLG product family group, are taught by remote wire, and have the longest sender to receiver span. SGS light grids can be commissioned quickly thanks to their simple "Click & Go" assembly feature and setup. In addition, features

such as auto-muting, auto-teach, and an alignment aid provide more uptime. A specially developed multi-connector also makes it easy to connect a series of multiple SGS light grids to a larger unit. Available with optional aluminum stabilizer for stand-alone mounting – it's that simple!

At a glance

- Variable detection lengths from 600 mm up to 1,400 mm (in 160 mm increments)
- Simple teach-in setup via cable
- Optional parameter setting with teach-in button, no PC required
- Maximum range 10 m
- Response time 18 ms
- 25 mm or 45 mm MDO possible
- Highly immune to sunlight at 150,000 lux
- Small blind zone < 11 mm

Your benefits

- Small, slim and sleek design enables easy integration into applications
- Slim and flat models offer flexible mounting options and optimize shelf/bin space while reducing damage
- Customized preset configurations or set parameters via one-touch teach-in with no PC
- Optical synchronization eliminates the need to lay cables, saving time
- Optional: Capacitive teach-in button and LEDs make commissioning easier for complex solutions
- Auto-teach and auto-muting enable Plug & Play. And, an alignment aid and "Click & Go" provide faster installation.



Additional information

Detailed technical data.....D-31

Ordering information.....D-33

Dimensional drawings.....D-38

Adjustments.....D-40

Connection type and diagram...D-40

Recommended accessories.....D-41

Special functions.....D-41

Setting the switching threshold via teaching process.....D-42

Configuration mode using the example of "cross beam/parallel beam".....D-43

→ www.mysick.com/en/SGS

D

Detailed technical data

Features

Technology	Sender/receiver
Task	Switching light grid
Minimum detectable object (MDO)	Parallel beam: ≥ 45 mm ... 85 mm Cross beam: ≥ 25 mm
Number of beams	8 ... 36
Configuration	Teach button with configuration software ¹⁾
Software features	Parallel beam Cross beam Output 1 high active/low active (normally open/closed), if light beam interrupted Automatic teach active/inactive With/without alignment aid Output 2 active/inactive (normally open/closed), if light beam interrupted With/without muting function at output 2 With/without muting function

¹⁾ For all T-types (cf. type code).

Performance

Maximum range ¹⁾	4 m 10 m
Minimum range ²⁾	Parallel beam: ≥ 0 m Cross beam: ≥ 0.3 m
Response time	Parallel beam: 19 ms Cross beam: 57 ms

¹⁾ No reserve for environmental issue and deterioration of the diode.

²⁾ $\pm 10^\circ$.

Interfaces

Inputs	Teach input
Connection type	Short cable with connector M8, 4-pin Short cable with connector, M12, 4-pin Cable open end

Mechanics/electronics

Wave length	IR, 950 nm
Supply voltage V_s	DC 24 V \pm 20 %
Power consumption sender ¹⁾	88 mA ... 148 mA
Power consumption receiver ¹⁾	70 mA
Ripple	< 5 V_{pp}
Output current I_{max}	100 mA
Output load capacitive	100 nF
Output load inductive	1 H
Initialization time	1 s
Dimensions (W x H x D)	25 mm x 672.4 mm x 8 mm ... 25 mm x 1,472.4 mm x 8 mm (SGS4) 25 mm x 932.4 mm x 8 mm ... 25 mm x 1,432.4 mm x 8 mm (SGS8)
Housing material	PMMA
Indication	LED
Synchronization	Optical
Enclosure rating	IP 65
Circuit protection	V_s connections reverse-polarity protected Output Q short-circuit protected Interference suppression
Weight	80 g ... 360 g
Switching frequency ²⁾	500 kHz 250 kHz

¹⁾ Without load.

²⁾ Depending on type.

Ambient data

Protection class	III
EMC	EN 60947-5-2
Ambient temperature	Operation: -25 °C ... +55 °C Storage: -25 °C ... +70 °C
Ambient light safety ¹⁾	Direct: 100,000 lx Indirect: 150,000 lx
Vibration resistance	5 g, 10 Hz ... 55 Hz (IEC 68-2-6)
Shock load	10 g / DIN EN 60068-2-29 / 16 ms

¹⁾ Sunlight.

Specific data

Beam separation	Optical light exit	Aluminum stabilizer	Model name	Ordering information
40 mm	Flat	-	SGS4-Fxxxxxx1xxx	D-33
		With stabilizer	SGS4-Fxxxxxx2xxx	D-33
	Slim	-	SGS4-Sxxxxxx1xxx	D-34
		With stabilizer	SGS4-Sxxxxxx2xxx	D-34
80 mm	Flat	With stabilizer	SGS8-Fxxxxxx2xxx	D-35
	Slim	-	SGS8-Sxxxxxx1xxx	D-35
		With stabilizer	SGS8-Sxxxxxx2xxx	D-35

Ordering information

The part numbers below show a selection of common configurations and represent only a portion of the product portfolio. The type code on page D-36 indicates all possible configurations that can be ordered.

Please note: Sender and receiver are only offered as a pair.

SGS4-Fxxxxxx1xxx

- **Beam separation:** 40 mm
- **Optical light exit:** Flat
- **Aluminum stabilizer:** -

Working range	Detection height	Switching output	Model name	Part no.
3 m	760 mm	1 x NPN	SGS4-F076N3PS1T00	1208788
			SGS4-F076N3CS1T00	1208793
		2 x PNP	SGS4-F076F3PS1W14	1209181
	920 mm	1 x NPN	SGS4-F092N3CS1T00	1208794
	1,080 mm	1 x PNP	SGS4-F108P3PS1W00	1045008
	1,400 mm	1 x PNP	SGS4-F140P3PS1W00	1045012
7 m	600 mm	1 x PNP	SGS4-F060P7PS1W00	1209723
	760 mm	1 x PNP	SGS4-F076P7PS1W00	1209287
	920 mm	1 x NPN	SGS4-F092N7PS1W00	1209012
		1 x PNP	SGS4-F092P7PS1T00	1208151
	1,080 mm	1 x PNP	SGS4-F092P7PS1W00	1047211
			SGS4-F108P7PS1W00	1045010
	1,400 mm	1 x PNP	SGS4-F108P7PS1W02	1047500
			SGS4-F140P7PS1W00	1045014

SGS4-Fxxxxxx2xxx

- **Beam separation:** 40 mm
- **Optical light exit:** Flat
- **Aluminum stabilizer:** With stabilizer

Working range	Detection height	Switching output	Model name	Part no.
3 m	1,080 mm	1 x PNP	SGS4-F108P3PS2T01	1207780
	1,240 mm	1 x PNP	SGS4-F124P3PS2T00	1048038
	1,400 mm	1 x PNP	SGS4-F140P3PS2T00	1208809

D

SGS4-Sxxxxxx1xxx

- Beam separation: 40 mm
- Optical light exit: Slim
- Aluminum stabilizer: -

Working range	Detection height	Switching output	Model name	Part no.
3 m	760 mm	1 x PNP	SGS4-S076P3PS1W00	1046966
			SGS4-S076P3PS1T00	1047092
	920 mm	1 x PNP	SGS4-S092P3PS1T00	1208201
			1,080 mm	1 x PNP
	SGS4-S108P3PS1W02	1209567		
	SGS4-S108P3PS1W00	1045007		
	SGS4-S108P3PS1T00	1209472		
	1,240 mm	1 x NPN	SGS4-S108N3PS1T00	1208155
			SGS4-S124N3PS1T0D	1209172
		1,400 mm	1 x PNP	SGS4-S140P3PS1T00
SGS4-S140P3PS1W00				1045011
7 m	600 mm	1 x PNP	SGS4-S060P7PS1W00	1209722
	760 mm	1 x PNP	SGS4-S076P7PS1W00	1209288
	920 mm	1 x PNP	SGS4-S092P7PS1T00	1208200
			SGS4-S092P7PS1W00	1208596
	1,080 mm	1 x PNP	SGS4-S108P7PS1T00	1209457
			SGS4-S108P7PS1W00	1045009
	1,400 mm	2 x PNP	SGS4-S140F7PS1T00	1047077
		1 x PNP	SGS4-S140P7PS1W00	1045013

SGS4-Sxxxxxx2xxx

- Beam separation: 40 mm
- Optical light exit: Slim
- Aluminum stabilizer: With stabilizer

D

Working range	Detection height	Switching output	Model name	Part no.
3 m	920 mm	1 x PNP	SGS4-S092P3PS2T00	1208108
	1,080 mm	1 x PNP	SGS4-S108P3PS2T07	1207519
	1,240 mm	1 x PNP	SGS4-S124P3PS2W00	1047815
			SGS4-S124P3PS2W04	1047903
	1,400 mm	1 x PNP	SGS4-S140P3PS2T00	1208109
7 m	1,080 mm	2 x PNP	SGS4-S108F7TS2W17	1209503
	1,400 mm	1 x PNP	SGS4-S140P7PS2T00	1208241

SGS8-Fxxxxxx2xxx

- **Beam separation:** 80 mm
- **Optical light exit:** Flat
- **Aluminum stabilizer:** With stabilizer

Working range	Detection height	Switching output	Model name	Part no.
3 m	880 mm	1 x PNP	SGS8-F088P3PS2W0E	1208797
	1,040 mm	1 x PNP	SGS8-F104P3PS2W0C	1208451
			SGS8-F104P3PS2W0E	1208610
	1,200 mm	1 x PNP	SGS8-F120P3PS2W0C	1208517
			SGS8-F120P3PS2W0E	1208611
1,360 mm	1 x PNP	SGS8-F136P3PS2W0C	1208516	

SGS8-Sxxxxxx1xxx

- **Beam separation:** 80 mm
- **Optical light exit:** Slim
- **Aluminum stabilizer:** -

Working range	Detection height	Switching output	Model name	Part no.
3 m	560 mm	2 x PNP	SGS8-S056F3PS1T00	1209297
		1 x PNP	SGS8-S056P3PS1W00	1208141
	720 mm	1 x PNP	SGS8-S072P3PS1W00	1209568
	880 mm	1 x PNP	SGS8-S088P3PS1W00	1209597
	1,200 mm	1 x PNP	SGS8-S120P3PS1T00	1209294
7 m	1,040 mm	2 x PNP	SGS8-S104F7PC1WA4	1045016
			SGS8-S104F7PS1T00	1047499
			SGS8-S104F7PS1WA4	1045015

SGS8-Sxxxxxx2xxx

- **Beam separation:** 80 mm
- **Optical light exit:** Slim
- **Aluminum stabilizer:** With stabilizer

Working range	Detection height	Switching output	Model name	Part no.
3 m	720 mm	1 x PNP	SGS8-S072P3PS2W0C	1208519
	880 mm	1 x PNP	SGS8-S088P3PS2T00	1207983
			SGS8-S088P3PS2W00	1047998
	1,200 mm	1 x PNP	SGS8-S120P3PS2W0C	1208452
	1,360 mm	1 x PNP	SGS8-S136P3PS2T00	1209554
SGS8-S136P3PS2W00			1047161	

D

Dimensional drawings

SGS4-Fxxxxxxx1xxx
 SGS8-Fxxxxxxx1xxx

Flat, without stabilizer

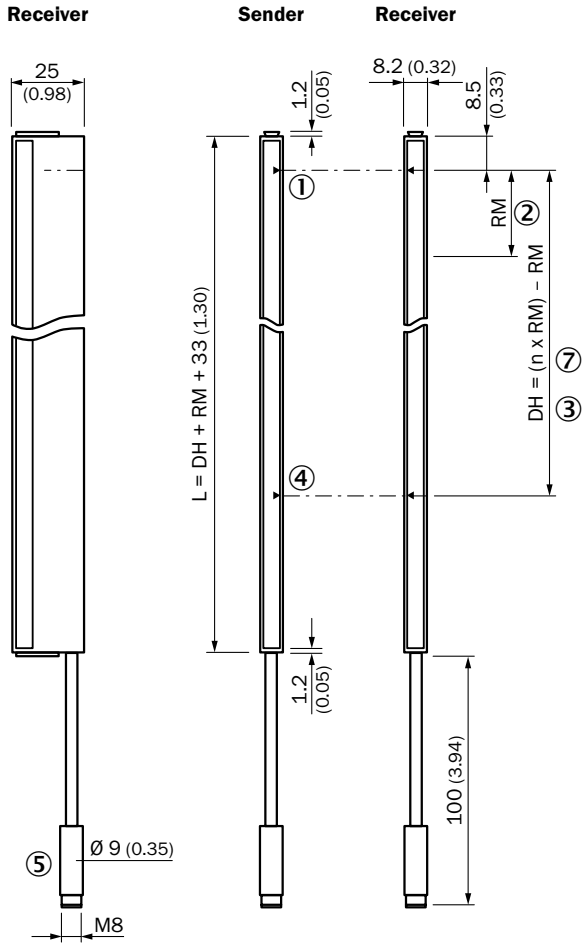

All dimensions in mm (inch)

SGS4-Fxxxxxxx2xxx
 SGS8-Fxxxxxxx2xxx

Flat, with stabilizer

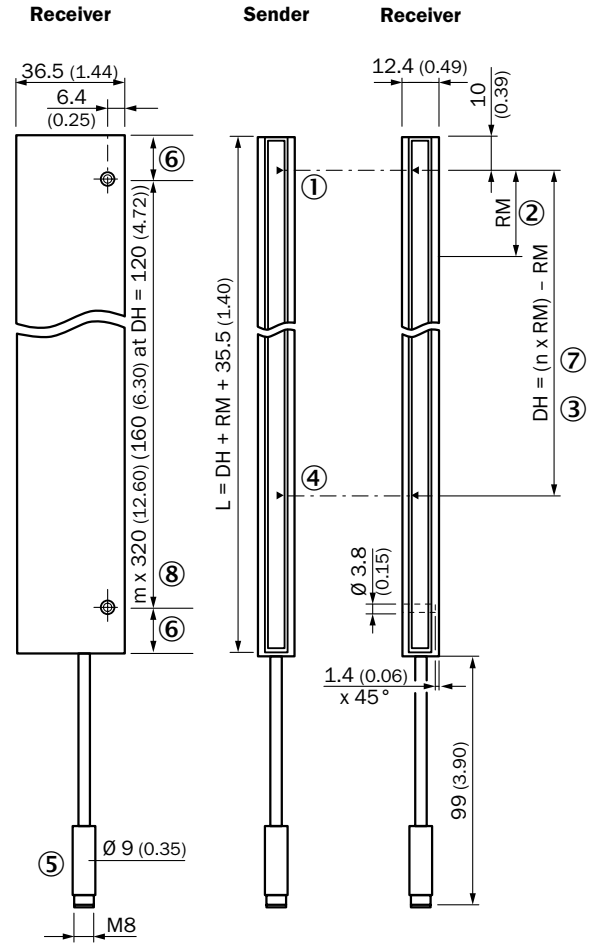

All dimensions in mm (inch)

- ① Last beam
- ② Beam separation RM
- ③ DH - Detection height (n x RM) - RM
- ④ First beam
- ⑤ Connection
- ⑥ Same distance
- ⑦ n = beam
- ⑧ m = mounting hole



SGS4-Sxxxxxx1xxx
SGS8-Sxxxxxx1xxx

Slim, without stabilizer

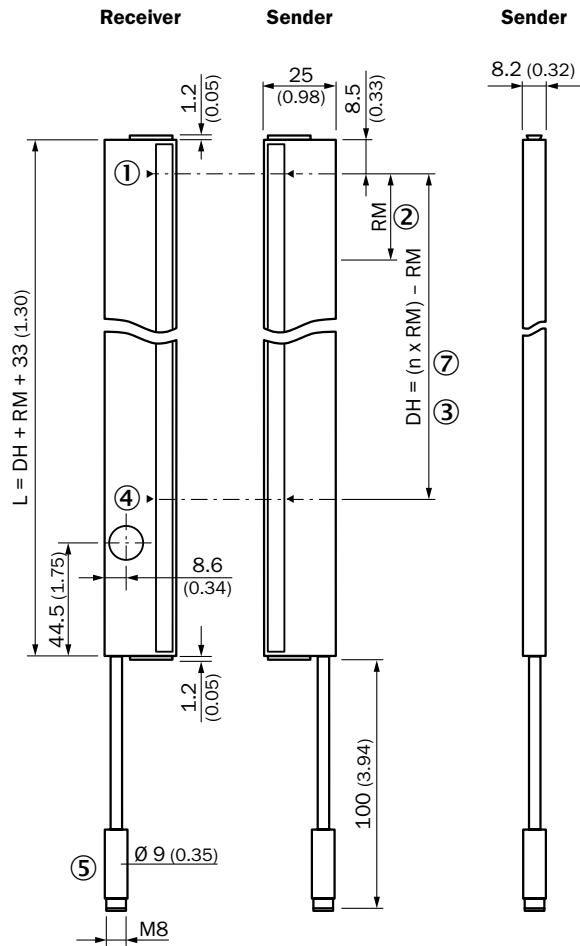

All dimensions in mm (inch)

SGS4-Sxxxxxx2xxx
SGS8-Sxxxxxx2xxx

Slim, with stabilizer

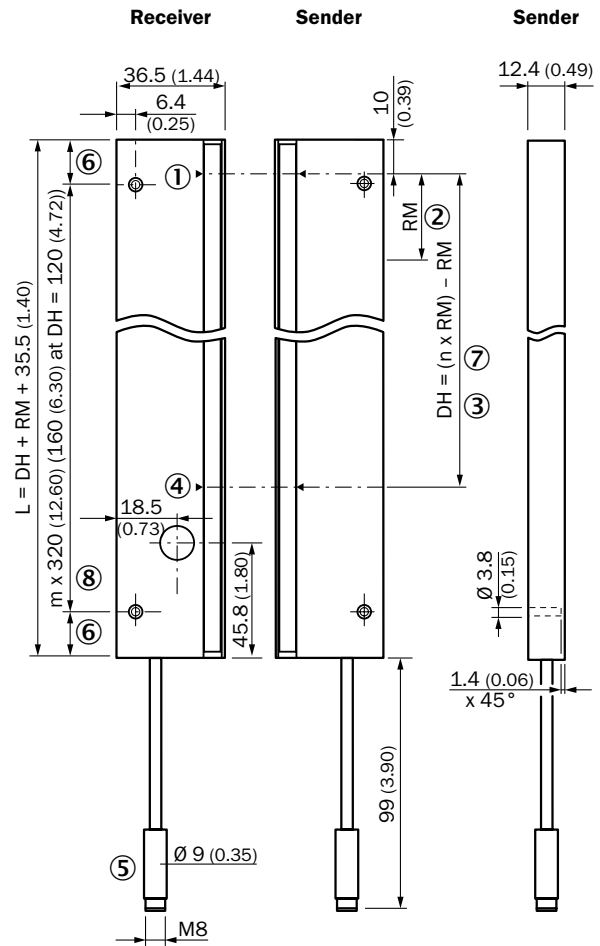

All dimensions in mm (inch)

- ① Last beam
- ② Beam separation RM
- ③ DH - Detection height (n x RM) - RM
- ④ First beam
- ⑤ Connection
- ⑥ Same distance
- ⑦ n = beam
- ⑧ m = mounting hole



Adjustments

Receiver, LED indication

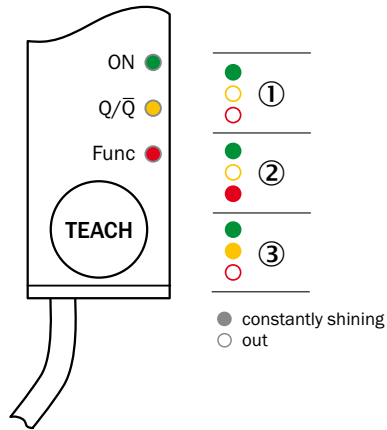

- ① Supply voltage
- ② Active, if teach-in button is pressed
- ③ No object in the light path

Connection type and diagram

**Sender
 Connector
 M8, 4-pin**

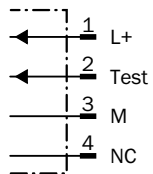
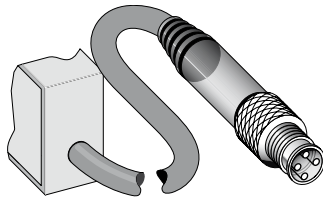

**Receiver teach PNP/NPN
 Connector
 M8, 4-pin**

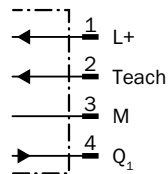
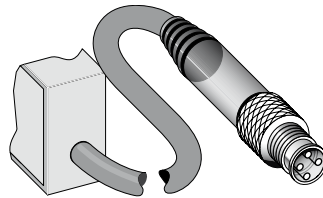

**Receiver 2 x PNP/2 x NPN
 Connector
 M8, 4-pin**

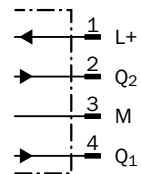
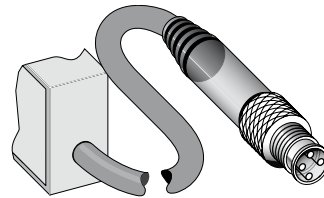



D

Recommended accessories



Complete accessories for SGS include: 2 female connector cables and 1 bracket.

Please take note of the number of pins on the connector when choosing connection cables.

Terminal and alignment brackets

	Brief description	Model name	Part no.
	Mounting bracket for mounting on the top sides. The mounting kit consists of 2 x BEF-SLG1 and 2 x BEF-SLG2.	BEF-SLG-SET1	2055427
	Bracket for SLG, stainless steel, 4 pcs	VZA-SLG	2048519

Plug connectors and cables

	Brief description	Model name	Part no.
 Illustration may differ	Female connector, M8, 4-pin, straight, 2 m, PVC	DOL-0804-G02M	6009870
	Female connector, M8, 4-pin, straight, 5 m, PVC	DOL-0804-G05M	6009872
	Female connector, M8, 4-pin, straight, 10 m, PVC	DOL-0804-G10M	6010754
 Illustration may differ	Female connector, M12, 4-pin, straight, 2 m, PVC	DOL-1204-G02M	6009382
	Female connector, M12, 4-pin, straight, 5 m, PVC	DOL-1204-G05M	6009866
	Female connector, M12, 4-pin, straight, 10 m, PVC	DOL-1204-G10M	6010543

For additional accessories including dimensional drawings, please see page E-14.

Special functions

Optical synchronisation

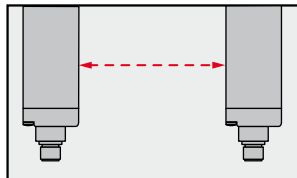

The light grid communicates via the light beams. A cable is not necessary for the optical synchronisation.

Setting the switching threshold via teaching process

1. Light grid in RUN mode, green LED "ON" illuminates, yellow LED "Q" illuminates.

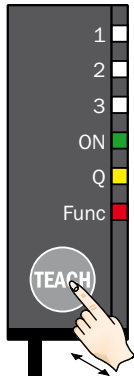

1 s ... 5 s

Press the teach button for 1 s to 5 s. During the teach process the green LEDs illuminates sequentially. The red LED "Func" illuminates.

2. Alignment aid is automatically activated for 10 s.

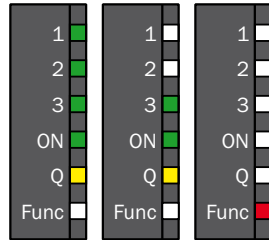

①

②

③

- ① = Optimum light reception.
- ② = Light reception not optimized,
→ **align sensors.**
- ③ = No light received,
→ **check light path.**

The light grid switches after 10 s automatically back into the RUN mode.

3. Light grid in RUN mode, green LED "ON" illuminates, yellow LED "Q" illuminates.

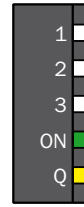

The switching threshold is set.

Configuration mode using the example of “cross beam/parallel beam”

If the teach button is pressed longer than 5 s, you switch into the configuration mode. In the configuration mode the menu items are indicated by the green LEDs. If the teach button is then pressed for < 1 s, the respective function is activated or reset (yellow LED on or off). If the teach button is pressed for 1 s to 5 s long, you switch to the next menu item. To exit the configuration mode, press the teach button for > 5 s or wait for 30 s.

1. Light grid in RUN mode, green LED “ON” illuminates, yellow LED “Q” illuminates.

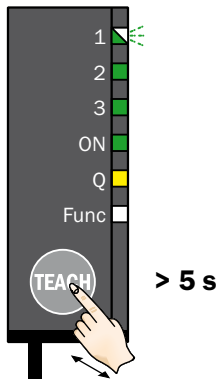

2. Cross or parallel beam set up.¹⁾

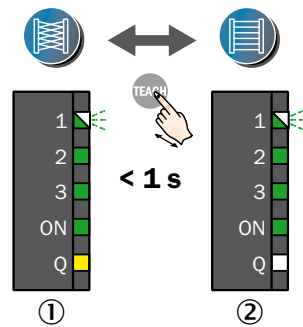

3. Go to the next menu item.

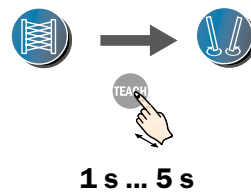

4. Exit the configuration mode.

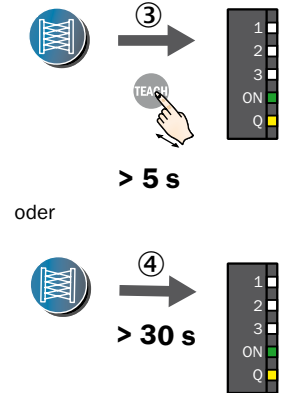

Press teach button > 5 s. The light grid switches into the configuration mode – menu item “cross beam/parallel beam”. The first green LED from top flashes.

- ① = Yellow LED on, → “Crossed beam” active.
- ② = Yellow LED off, → “Parallel beam” active.

Press teach button for 1 s to 5 s to switch to the next menu item (in this case “alignment aid”).

- ③ = Press teach button > 5 s, → save parameters.
- ④ = Wait > 30 s, → parameters not saved.

Press teach button < 1 s to switch between the settings.

¹⁾ Configure the light grid in a 3-way cross-beam or a parallel-oriented operating principle. The cross beam can be used to improve the resolution in the middle detection area. Objects up to a size of 25 mm can be detected. The response time increases.

The other menu items in sequence of the menu setting of the light grid

Alignment aid ²⁾	Invert switching output	Auto-teach ³⁾	Pushbutton lock	Standard values ⁴⁾	Invert second switching output	Muting ⁵⁾
active	Q ₁	active	active	active	Q ₂	active
inactive	Q̄ ₁	inactive	inactive	inactive	Q̄ ₂	inactive

²⁾ The alignment aid is recommended for applications with high ranges. The signal strength of the receiver is permanently displayed by four green alignment LEDs. Depending on the strength, the number of illuminated LEDs differ. When reception is strong, all four LEDs illuminate. The alignment aid must be deactivated again after alignment.

³⁾ After commissioning (power on), the switching threshold is taught in automatically. No object should be between the sender and receiver during this process.

⁴⁾ With standard values “active” all parameters are reset to the delivery state.

⁵⁾ If a beam is interrupted permanently, it disappears after > 60 s, and the switching output Q₁ is enabled again. If a second switching output is present, it remains inactive.



A winning combination: sensors and accessories from SICK

In order to ensure optimal integration of sensors into your systems, it is essential that your accessories are perfectly tuned to each other. This applies not only to the connection and mounting systems, but also to reflectors, alignment aids and further special accessories.

Reliable signal transmission guarantees productivity – high-quality connectivity components with long service life reduce costs. That is why SICK offers the right connection systems for any application or sector, whether for the material handling, packaging, automotive or food and beverage industry. The extensive range of plug connectors and distributors makes it possible to achieve the right cabling for every application, even under the harshest and most difficult conditions.

The requirements of mounting systems for sensors are just as diverse as their areas of application. With its clever mounting concepts, SICK offers the right solutions for mounting, alignment and protection of industrial SICK sensor systems. Efficient and functional.

E

Product  Finder

www.mysick.com/products







Further accessories can be found online: enter the part no. of the product, and make your selection in “Related content: Accessories”.



Advanced automation light grids	E-2
Standard automation light grids.	E-8
Smart light grids	E-14
Dimensional drawings	E-16

Advanced automation light grids

Adapters/distributors (without cable)

	Brief description	Model name	Part no.	MLG Standard	MLG Progr.	MLG Progr. 12-pin	MLG PROFIBUS	MLG CANopen	MLG Analog Output	XLG Progr.
	PROFIBUS adapter, straight	ADAPT-PB-GE-MLG	1027921	-	-	-	●	-	-	-
	PROFIBUS adapter, angled	ADAPT-PB-WI-MLG	1027901	-	-	-	●	-	-	-
	CAN adapter, straight	ADPT-CAN-GE-MLG	1052957	-	-	-	-	●	-	-
	T-junction, 1x plug M12, 8-pin and 2x socket M12, 8-pin	SBO-02F12-SM	6029306	-	●	-	-	-	●	●
	T-junction, 1x plug M12, 5-pin and 2x socket M12, 5-pin	SBO-02G12-SM	6029305	●	-	-	●	●	-	-
	Connection cable, socket RS-232, USB, 0.35 m	Converter RS-232 to USB	6035396	-	●	●	-	-	●	●

Cleaning agent









	Brief description	Model name	Part no.	MLG Standard	MLG Progr.	MLG Progr. 12-pin	MLG PROFIBUS	MLG CANopen	MLG Analog Output	XLG Progr.
	Plastic cleaner and care product, anti-static	Plastic cleaner	5600006	●	●	●	●	●	●	●

Lens cloths





	Brief description	Model name	Part no.	MLG Standard	MLG Progr.	MLG Progr. 12-pin	MLG PROFIBUS	MLG CANopen	MLG Analog Output	XLG Progr.
	-	Optical cleaning cloth	4003353	●	●	●	●	●	●	●

E









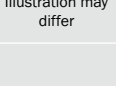

Mounting brackets/plates

	Brief description	Model name	Part no.	MLG Standard	MLG Progr.	MLG Progr. 12-pin	MLG PROFIBUS	MLG CANopen	MLG Analog Output	XLG Progr.
	Mounting kit, mounting bracket, adjustable, 1 set = 4 pcs	BEF-1SHABAAL4	2017751	●	●	●	●	●	●	●
	Omega bracket (24 mm), mounting position: front side, aluminum, 2 pcs	BEF-2SMKEAAL2	2045884	●	●	●	●	●	●	●
	Omega bracket (24 mm), mounting position: front side, aluminum, 4 pcs	BEF-2SMKEAAL4	2044848	●	●	●	●	●	●	●
	Mounting bracket, adjustable, stainless steel, for all detection heights, 4 pcs	BEF-2SMKEAES4	2030288	●	●	●	●	●	●	●
	Mounting kit 1, adjustable, swivel mount, for all detection heights in small housings, plastic, without mounting material, 4 pcs	BEF-2SMKEAKU4	2019649	●	●	●	●	●	●	●
	Mounting kit, mounting bracket, rigid, L-shaped, for all detection heights, 4 pcs	BEF-3WNGBAST4	7021352	●	●	●	●	●	●	●
	Mounting kit, side bracket including four sliding nuts for MLG/ELG/HLG, 4 pcs	BEF-NUT-MLG	2023696	●	●	●	●	●	●	●
	Sliding nuts, M5, 4 pcs	Sliding nuts	2017550	●	●	●	●	●	●	●
	Mounting bracket, steel, zinc coated, without mounting material, 4 pcs	BEF-WK-XLG	2029100	●	●	●	●	●	●	●

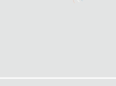

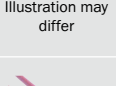







Others

	Brief description	Model name	Part no.	MLG Standard	MLG Progr.	MLG Progr. 12-pin	MLG PROFIBUS	MLG CANopen	MLG Analog Output	XLG Progr.
	Adapter for alignment aid AR60	Adapter for AR60, for small housing profile	4032462	●	●	●	●	●	●	●
	Alignment aid for various sensors, 60 m sensing range, laser class 2	Laser alignment aid AR60	1015741	●	●	●	●	●	●	●
	Acrylic glass tube as protective housing with screwable aluminum end cap	ALG IP housing	On demand	●	●	●	●	●	●	●
	Housing column for automation light grids, protection for outdoor applications	ALG protection housing	On demand	●	●	●	●	●	●	●

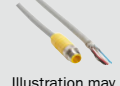





Plug connectors and cables

	Brief description	Model name	Part no.	MLG Standard	MLG Progr.	MLG Progr. 12-pin	MLG PROFIBUS	MLG CANopen	MLG Analog Output	XLG Progr.
	Female connector, M12, 5-pin, straight, 5 m, CAN	CAN cable 5 m (socket-open end)	6021166	-	-	-	-	●	-	-
	Connection cable, M12, 5-pin, plug straight/socket straight, 1 m, CAN	CAN cable (plug-socket)	6021164	-	-	-	-	●	-	-
 Illustration may differ	Female connector, M12, 5-pin, straight, 2 m, PVC	DOL-1205-G02M	6008899	●	-	●	●	●	-	-
	Female connector, M12, 5-pin, straight, 5 m, PVC	DOL-1205-G05M	6009868	●	-	●	●	●	-	-
	Female connector, M12, 5-pin, straight, 10 m, PVC	DOL-1205-G10M	6010544	●	-	●	●	●	-	-
	Female connector, M12, 5-pin, straight, 15 m, PVC	DOL-1205-G15M	6029215	●	-	●	●	●	-	-
 Illustration may differ	Female connector, M12, 5-pin, straight, 2 m, PUR halogen free	DOL-1205-G02MC	6025906	●	-	●	●	●	-	-
	Female connector, M12, 5-pin, straight, 5 m, PUR halogen free	DOL-1205-G05MC	6025907	●	-	●	●	●	-	-
	Female connector, M12, 5-pin, straight, 10 m, PUR halogen free	DOL-1205-G10MC	6025908	●	-	●	●	●	-	-
	Female connector, M12, 5-pin, straight, 10 m, PUR halogen free, shielded	DOL-1205-G10MAC	6036385	-	-	-	-	●	-	-
 Illustration may differ	Female connector, M12, 5-pin, straight, 2 m, PVC, food specification	DOL-1205-G02MN	6028140	●	-	●	●	●	-	-
	Female connector, M12, 5-pin, straight, 5 m, PVC, food specification	DOL-1205-G05MN	6028141	●	-	●	●	●	-	-
	Female connector, M12, 5-pin, straight, 10 m, PVC, food specification	DOL-1205-G10MN	6028142	●	-	●	●	●	-	-
 Illustration may differ	Female connector, M12, 5-pin, straight, 5 m, PROFIBUS	DOL-1205-G05MQ	6026006	-	-	-	●	-	-	-
	Female connector, M12, 5-pin, straight, 10 m, PROFIBUS	DOL-1205-G10MQ	6026008	-	-	-	●	-	-	-
	Female connector, M12, 5-pin, straight, 12 m, PROFIBUS	DOL-1205-G12MQ	6032636	-	-	-	●	-	-	-
 Illustration may differ	Female connector, M12, 5-pin, straight, 6 m, CANopen	DOL-1205-G06MK	6028326	-	-	-	-	●	-	-
 Illustration may differ	Female connector, M12, 5-pin, angled, 2 m, PVC	DOL-1205-W02M	6008900	●	-	●	●	●	-	-
	Female connector, M12, 5-pin, angled, 5 m, PVC	DOL-1205-W05M	6009869	●	-	●	●	●	-	-
	Female connector, M12, 5-pin, angled, 10 m, PVC	DOL-1205-W10M	6010542	●	-	●	●	●	-	-
 Illustration may differ	Female connector, M12, 8-pin, straight, 2 m, PVC, shielded	DOL-1208-G02MA	6020633	-	●	-	-	-	●	●
	Female connector, M12, 8-pin, straight, 5 m, PVC, shielded	DOL-1208-G05MA	6020993	-	●	-	-	-	●	●
	Female connector, M12, 8-pin, straight, 10 m, PVC, shielded	DOL-1208-G10MA	6022152	-	●	-	-	-	●	●
	Female connector, M12, 8-pin, straight, 15 m, PVC, shielded	DOL-1208-G15MA	6022153	-	●	-	-	-	●	●
	Female connector, M12, 8-pin, straight, 5 m, PUR halogen free, shielded	DOL-1208-G05MACR	6037517	-	●	-	-	-	●	●
 Illustration may differ	Female connector, M12, 8-pin, straight, 10 m, PUR halogen free, shielded	DOL-1208-G10MAC	6038832	-	●	-	-	-	●	●
	Female connector, M12, 8-pin, angled, 2 m, PVC, shielded	DOL-1208-W02MA	6020992	-	●	-	-	-	●	●
	Female connector, M12, 8-pin, angled, 5 m, PVC, shielded	DOL-1208-W05MA	6021033	-	●	-	-	-	●	●
 Illustration may differ	Female connector, M12, 8-pin, angled, 10 m, PUR halogen free, shielded	DOL-1208-W10MAC	6037726	-	●	-	-	-	●	●





E

	Brief description	Model name	Part no.	MLG Standard	MLG Progr.	MLG Progr. 12-pin	MLG PROFIBUS	MLG CANopen	MLG Analog Output	XLG Progr.
 Illustration may differ	Female connector, M12, 12-pin, straight, 2 m, PVC, shielded	DOL-1212-G02MA	6034604	-	-	●	-	-	●	-
	Female connector, M12, 12-pin, straight, 5 m, PVC, shielded	DOL-1212-G05MA	6034605	-	-	●	-	-	●	-
	Female connector, M12, 12-pin, straight, 10 m, PVC, shielded	DOL-1212-G10MAS01	6037356	-	-	●	-	-	●	-
	Female connector, M12, 5-pin, straight	DOS-1205-G	6009719	●	-	●	●	●	-	-
	Female connector, M12, 5-pin, angled	DOS-1205-W	6009720	●	-	●	●	●	-	-
	Female connector, M12, 8-pin, straight, shielded	DOS-1208-GA	6028369	-	●	-	-	-	●	●
	Female connector, M12, 8-pin, angled, shielded	DOS-1208-WA	6043358	-	●	-	-	-	●	●
 Illustration may differ	Female connector, M12, 5-pin, 5 m, PVC	DeviceNet cable	6030741	-	-	-	-	●	-	-
 Illustration may differ	Configuration cable, 2 m, PVC	DSL-8D04-G02M	2023695	-	●	-	-	-	●	●
	Connection cable, M12, 5-pin, plug straight/socket straight, 1 m, PUR halogen free	DSL-1205-G01MC	6029280	●	-	●	●	●	-	-
	Connection cable, M12, 5-pin, plug straight/socket straight, 1.5 m, PUR halogen free	DSL-1205-G1M5C	6029281	●	-	●	●	●	-	-
	Connection cable, M12, 5-pin, plug straight/socket straight, 2 m, PUR halogen free	DSL-1205-G02MC	6025931	●	-	●	●	●	-	-
	Connection cable, M12, 5-pin, plug straight/socket straight, 5 m, PUR halogen free	DSL-1205-G05MC	6029282	●	-	●	●	●	-	-
	Connection cable, M12, 5-pin, plug straight/socket straight, 10 m, PUR halogen free	DSL-1205-G10MC	6038954	●	-	●	●	●	-	-
	Connection cable, M12, 5-pin, plug straight/socket straight, 10 m, PROFIBUS	DSL-1205-G10MQ	6032640	-	-	-	●	-	-	-
	Connection cable, M12, 5-pin, plug straight/socket straight, 1 m, CAN	DSL-1205-G01MK	6021164	-	-	-	-	●	-	-
	Connection cable, M12, 5-pin, plug straight/socket straight, 6 m, CAN	DSL-1205-G06MK	6028327	-	-	-	-	●	-	-
	Connection cable, M12, 8-pin, plug straight/socket straight, 1 m, PUR halogen free, shielded	DSL-1208-G01MAC	6026625	-	●	-	-	-	●	●
	Connection cable, M12, 8-pin, plug straight/socket straight, 2 m, PUR halogen free, shielded	DSL-1208-G02MAC	6030121	-	●	-	-	-	●	●
	Connection cable, M12, 8-pin, plug straight/socket straight, 5 m, PUR halogen free, shielded	DSL-1208-G05MAC	6032325	-	●	-	-	-	●	●
	Connection cable, M12, 8-pin, plug straight/socket straight, 10 m, PUR halogen free, shielded	DSL-1208-G10MAC	6034901	-	●	-	-	-	●	●
	Cable, by the meter, PROFIBUS	LTG-2102-MW	6021355	-	-	-	●	-	-	-





	Brief description	Model name	Part no.	MLG Standard	MLG Progr.	MLG Progr. 12-pin	MLG PROFIBUS	MLG CANopen	MLG Analog Output	XLG Progr.
	Male connector, M12, 5-pin, straight, 5 m, PROFIBUS	STL-1205-G05MQ	6026005	-	-	-	●	-	-	-
	Male connector, M12, 5-pin, straight, 10 m, PROFIBUS	STL-1205-G10MQ	6026007	-	-	-	●	-	-	-
	Male connector, M12, 5-pin, straight, 12 m, PROFIBUS	STL-1205-G12MQ	6032635	-	-	-	●	-	-	-
	Male connector, M12, 5-pin, straight, 15 m, PROFIBUS	STL-1205-G15MQ	6036898	-	-	-	●	-	-	-
	Female connector, M12, 5-pin, straight, shielded, PROFIBUS	PR-DOS-1205-G	6021353	-	-	-	●	-	-	-
	Male connector, M12, 5-pin, straight, shielded, PROFIBUS	PR-STE-1205-G	6021354	-	-	-	●	-	-	-
	T-junction, 1x plug M12, 8-pin, and 2x socket M12, 8-pin	SBO-02F12-SM	6029306	-	●	-	-	-	●	●
	T-junction, 1x plug M12, 5-pin, and 2x socket M12, 5-pin	SBO-02G12-SM	6029305	●	-	-	●	●	-	-
	Male connector, M12, 5-pin, straight	STE-1205-G	6022083	●	-	●	●	●	-	-
	Male connector, M12, 5-pin, straight, terminal resistor	STE-1205-GKEND	6037193	-	-	-	-	●	-	-

Terminal and alignment brackets

	Brief description	Model name	Part no.	MLG Standard	MLG Progr.	MLG Progr. 12-pin	MLG PROFIBUS	MLG CANopen	MLG Analog Output	XLG Progr.
	Plate G for universal bar clamp, steel, zinc coated, incl. universal bar clamp and mounting material	BEF-KHS-G01	2022464	●	●	●	●	●	●	●
	Universal bar clamp, zinc, die-cast	BEF-KHS-KH1	2022726	●	●	●	●	●	●	●
	Mounting rod, straight, 300 mm, steel, zinc coated, without mounting material	BEF-MS12G-B	4056055	●	●	●	●	●	●	●
	Mounting rod, straight, 200 mm, stainless steel, without mounting material	BEF-MS12G-NA	4058914	●	●	●	●	●	●	●
	Mounting rod, straight, 300 mm, stainless steel, without mounting material	BEF-MS12G-NB	4058915	●	●	●	●	●	●	●
	Mounting rod, L-shaped, 150 mm x 150 mm, steel, zinc coated, without mounting material	BEF-MS12L-A	4056052	●	●	●	●	●	●	●
	Mounting rod, L-shaped, 250 mm x 250 mm, steel, zinc coated, without mounting material	BEF-MS12L-B	4056053	●	●	●	●	●	●	●
	Mounting rod, L-shaped, 150 mm x 150 mm, stainless steel, without mounting material	BEF-MS12L-NA	4058912	●	●	●	●	●	●	●
	Mounting rod, L-shaped, 250 mm x 250 mm, stainless steel, without mounting material	BEF-MS12L-NB	4058913	●	●	●	●	●	●	●





E

	Brief description	Model name	Part no.	MLG Standard	MLG Progr.	MLG Progr. 12-pin	MLG PROFIBUS	MLG CANopen	MLG Analog Output	XLG Progr.
	Mounting rod, L-shaped, 150 mm x 70 mm x 150 mm, steel, zinc coated, without mounting material	BEF-MS12Z-A	4056056	●	●	●	●	●	●	●
	Mounting rod, L-shaped, 150 mm x 70 mm x 250 mm, steel, zinc coated, without mounting material	BEF-MS12Z-B	4056057	●	●	●	●	●	●	●
	Mounting rod, L-shaped, 100 mm x 150 mm x 200 mm, steel, zinc coated, without mounting material	BEF-MS12Z-C	4064563	●	●	●	●	●	●	●
	Mounting rod, L-shaped, 150 mm x 70 mm x 150 mm, stainless steel, without mounting material	BEF-MS12Z-NA	4058916	●	●	●	●	●	●	●
	Mounting rod, L-shaped, 150 mm x 70 mm x 250 mm, stainless steel, without mounting material	BEF-MS12Z-NB	4058917	●	●	●	●	●	●	●
	Rod bar clamp for rod diameter of 12 mm, aluminum, 2 screws M6 x 30, 2 spring discs	BEF-RMC-D12	5321878	●	●	●	●	●	●	●



Standard automation light grids

Adapters/distributors (without cable)

	Brief description	Model name	Part no.	WLG	HLG	ELG Short Range	ELG Long Range	ELG Long Range Relay	PLG3	PLG6
	Sensor/actuator box, 4x M12, 5-pin, cable, 5 m, PUR halogen free	SBL-04D12-KC05	6028394	-	-	-	-	-	●	●
	Sensor/actuator box, 8x M12, 5-pin, cable, 5 m, PUR halogen free	SBL-08D12-KC05	6028396	-	-	-	-	-	●	●
	T-junction, 1x plug M12, 8-pin, and 2x socket M12, 8-pin	SBO-02F12-SM	6029306	-	●	-	-	-	-	-
	Y-junction, coupling M12 x 1 - 2x plug M12 x 1	SYL-1205-G0M3	6043534	-	-	-	-	-	●	●

Cleaning agent

	Brief description	Model name	Part no.	WLG	HLG	ELG Short Range	ELG Long Range	ELG Long Range Relay	PLG3	PLG6
	Plastic cleaner and care product, anti-static	Plastic cleaner	5600006	●	●	●	●	●	●	●











Lens cloths

	Brief description	Model name	Part no.	WLG	HLG	ELG Short Range	ELG Long Range	ELG Long Range Relay	PLG3	PLG6
	-	Optical cleaning cloth	4003353	●	●	●	●	●	●	●



E

Mounting brackets/plates









	Brief description	Model name	Part no.	WLG	HLG	ELG Short Range	ELG Long Range	ELG Long Range Relay	PLG3	PLG6
	Mounting kit, mounting bracket, adjustable, 1 set = 4 pcs	BEF-1SHABAAL4	2017751	-	-	●	●	●	-	-

	Brief description	Model name	Part no.	WLG	HLG	ELG Short Range	ELG Long Range	ELG Long Range Relay	PLG3	PLG6
	Omega bracket (24 mm), mounting position: front side, aluminum, 2 pcs	BEF-2SMKEAAL2	2045884	-	-	●	●	●	-	-
	Omega bracket (24 mm), mounting position: front side, aluminum, 4 pcs	BEF-2SMKEAAL4	2044848	-	-	●	●	●	-	-
	Mounting bracket, adjustable, stainless steel, for all detection heights, 4 pcs	BEF-2SMKEAES4	2030288	-	-	●	●	●	-	-
	Mounting kit 1, adjustable, swivel mount, for all detection heights in small housings, plastic, without mounting material, 4 pcs	BEF-2SMKEAKU4	2019649	-	●	●	●	●	-	-
	Mounting kit, mounting bracket, rigid, L-shaped, for all detection heights, 4 pcs	BEF-3WNGBAST4	7021352	-	-	●	●	●	-	-
	Mounting kit, side bracket including four sliding nuts for MLG/ELG/HLG, 4 pcs	BEF-NUT-MLG	2023696	-	-	●	●	●	-	-
	Sliding nuts with spring metal sheet for Bosch profile, 2x slot 8 and slot 10, including mounting material	BEF-NSBO-PLG	2041049	-	-	-	-	-	●	●
	Sliding nuts with spring metal ball for ITEM profile, 2x slot 6 and slot 8, including mounting material	BEF-NSIT-PLG	2041045	-	-	-	-	-	●	●
	Sliding nuts, M5, 4 pcs	Sliding nuts	2017550	-	-	●	●	●	-	-
	Round rod holder for round rods and tubes, including mounting material, 2 pcs	BEF-RD30-PLG	2040541	-	-	-	-	-	●	●
	Mounting bracket, steel, zinc coated, without mounting material, 4 pcs	BEF-WK-XLG	2029100	-	●	●	●	●	-	-
	Mounting bracket for WLG12, steel, zinc coated, including mounting material	BEF-WN-WLG12	2017567	●	-	-	-	-	-	-











Others

	Brief description	Model name	Part no.	WLG	HLG	ELG Short Range	ELG Long Range	ELG Long Range Relay	PLG3	PLG6
	Alignment aid for various sensors, 60 m sensing range, laser class 2	Laser alignment aid AR60	1015741	-	●	●	●	●	-	-
	Acrylic glass tube as protective housing with screwable aluminum end cap	ALG IP housing	On demand	-	-	●	●	●	-	-
	Housing column for automation light grids, protection for outdoor applications	ALG protection housing	On demand	-	-	●	●	●	-	-



Plug connectors and cables

	Brief description	Model name	Part no.	WLG	HLG	ELG Short Range	ELG Long Range	ELG Long Range Relay	PLG3	PLG6
 Illustration may differ	Female connector, M12, 4-pin, straight, 2 m, PVC	DOL-1204-G02M	6009382	-	-	●	●	●	●	●
	Female connector, M12, 4-pin, straight, 5 m, PVC	DOL-1204-G05M	6009866	-	-	●	●	●	●	●
	Female connector, M12, 4-pin, straight, 10 m, PVC	DOL-1204-G10M	6010543	-	-	●	●	●	●	●
	Female connector, M12, 4-pin, straight, 15 m, PVC	DOL-1204-G15M	6010753	-	-	●	●	●	●	●
	Female connector, M12, 4-pin, straight, 2 m, PUR halogen free	DOL-1204-G02MC	6025900	-	-	●	●	●	●	●
	Female connector, M12, 4-pin, straight, 5 m, PUR halogen free	DOL-1204-G05MC	6025901	-	-	●	●	●	●	●
	Female connector, M12, 4-pin, straight, 10 m, PUR halogen free	DOL-1204-G10MC	6025902	-	-	●	●	●	●	●
	Female connector, M12, 4-pin, straight, 15 m, PUR halogen free	DOL-1204-G15MC	6034749	-	-	●	●	●	●	●
 Illustration may differ	Female connector, M12, 4-pin, angled, 2 m, PVC	DOL-1204-W02M	6009383	-	-	●	●	●	●	●
	Female connector, M12, 4-pin, angled, 5 m, PVC	DOL-1204-W05M	6009867	-	-	●	●	●	●	●
	Female connector, M12, 4-pin, angled, 10 m, PVC	DOL-1204-W10M	6010541	-	-	●	●	●	●	●
	Female connector, M12, 4-pin, angled, 2 m, PUR halogen free	DOL-1204-W02MC	6025903	-	-	●	●	●	●	●
	Female connector, M12, 4-pin, angled, 5 m, PUR halogen free	DOL-1204-W05MC	6025904	-	-	●	●	●	●	●
	Female connector, M12, 4-pin, angled, 10 m, PUR halogen free	DOL-1204-W10MC	6025905	-	-	●	●	●	●	●
	Female connector, M12, 4-pin, angled, 15 m, PUR halogen free	DOL-1204-W15MC	6034752	-	-	●	●	●	●	●
 Illustration may differ	Female connector, M12, 5-pin, straight, 2 m, PVC	DOL-1205-G02M	6008899	●	-	-	-	●	-	-
	Female connector, M12, 5-pin, straight, 5 m, PVC	DOL-1205-G05M	6009868	●	-	-	-	●	-	-
	Female connector, M12, 5-pin, straight, 10 m, PVC	DOL-1205-G10M	6010544	●	-	-	-	●	-	-
	Female connector, M12, 5-pin, straight, 15 m, PVC	DOL-1205-G15M	6029215	●	-	-	-	●	-	-
	Female connector, M12, 5-pin, straight, 2 m, PUR halogen free	DOL-1205-G02MC	6025906	●	-	-	-	●	-	-
	Female connector, M12, 5-pin, straight, 5 m, PUR halogen free	DOL-1205-G05MC	6025907	●	-	-	-	●	-	-
	Female connector, M12, 5-pin, straight, 10 m, PUR halogen free	DOL-1205-G10MC	6025908	●	-	-	-	●	-	-
 Illustration may differ	Female connector, M12, 5-pin, straight, 2 m, PVC, food specification	DOL-1205-G02MN	6028140	●	-	-	-	●	-	-
	Female connector, M12, 5-pin, straight, 5 m, PVC, food specification	DOL-1205-G05MN	6028141	●	-	-	-	●	-	-
	Female connector, M12, 5-pin, straight, 10 m, PVC, food specification	DOL-1205-G10MN	6028142	●	-	-	-	●	-	-
 Illustration may differ	Female connector, M12, 5-pin, angled, 2 m, PVC	DOL-1205-W02M	6008900	●	-	-	-	●	-	-
	Female connector, M12, 5-pin, angled, 5 m, PVC	DOL-1205-W05M	6009869	●	-	-	-	●	-	-
	Female connector, M12, 5-pin, angled, 10 m, PVC	DOL-1205-W10M	6010542	●	-	-	-	●	-	-
	Female connector, M12, 5-pin, angled, 2 m, PUR halogen free	DOL-1205-W02MC	6025909	●	-	-	-	●	-	-
	Female connector, M12, 5-pin, angled, 5 m, PUR halogen free	DOL-1205-W05MC	6025910	●	-	-	-	●	-	-
	Female connector, M12, 5-pin, angled, 10 m, PUR halogen free	DOL-1205-W10MC	6025911	●	-	-	-	●	-	-





E

	Brief description	Model name	Part no.	WLG	HLG	ELG Short Range	ELG Long Range	ELG Long Range Relay	PLG3	PLG6
 <p>Illustration may differ</p>	Female connector, M12, 8-pin, straight, 2 m, PVC, shielded	DOL-1208-G02MA	6020633	-	●	-	-	-	-	-
	Female connector, M12, 8-pin, straight, 5 m, PVC, shielded	DOL-1208-G05MA	6020993	-	●	-	-	-	-	-
	Female connector, M12, 8-pin, straight, 10 m, PVC, shielded	DOL-1208-G10MA	6022152	-	●	-	-	-	-	-
	Female connector, M12, 8-pin, straight, 15 m, PVC, shielded	DOL-1208-G15MA	6022153	-	●	-	-	-	-	-
	Female connector, M12, 8-pin, straight, 5 m, PUR halogen free, shielded	DOL-1208-G05MACR	6037517	-	●	-	-	-	-	-
	Female connector, M12, 8-pin, straight, 10 m, PUR halogen free, shielded	DOL-1208-G10MAC	6038832	-	●	-	-	-	-	-
 <p>Illustration may differ</p>	Female connector, M12, 8-pin, angled, 2 m, PVC, shielded	DOL-1208-W02MA	6020992	-	●	-	-	-	-	-
	Female connector, M12, 8-pin, angled, 5 m, PVC, shielded	DOL-1208-W05MA	6021033	-	●	-	-	-	-	-
	Female connector, M12, 4-pin, straight	DOS-1204-G	6007302	-	-	●	●	●	●	●
	Female connector, M12, 4-pin, angled	DOS-1204-W	6007303	-	-	●	●	●	●	●
	Female connector, M12, 5-pin, straight	DOS-1205-G	6009719	●	-	-	-	●	-	-
	Female connector, M12, 5-pin, angled	DOS-1205-W	6009720	●	-	-	-	●	-	-
	Female connector, M12, 8-pin, straight, shielded	DOS-1208-GA	6028369	-	●	-	-	-	-	-
	Female connector, M12, 8-pin, angled, shielded	DOS-1208-WA	6043358	-	●	-	-	-	-	-
 <p>Illustration may differ</p>	Connection cable, M12, 4-pin, plug straight/socket straight, 0.6 m, PVC	DSL-1204-G0M6	6022565	-	-	●	●	●	●	●
	Connection cable, M12, 4-pin, plug straight/socket straight, 2 m, PVC	DSL-1204-G02M	6022567	-	-	●	●	●	●	●
	Connection cable, M12, 4-pin, plug straight/socket straight, 5 m, PVC	DSL-1204-G05M	6022569	-	-	●	●	●	●	●
	Connection cable, M12, 4-pin, plug straight/socket straight, 10 m, PVC	DSL-1204-G10M	6034406	-	-	●	●	●	●	●
	Connection cable, M12, 4-pin, plug straight/socket straight, 15 m, PVC	DSL-1204-G1M5	6034822	-	-	●	●	●	●	●
	Connection cable, M12, 4-pin, plug straight/socket straight, 20 m, PVC	DSL-1204-G20M	6034407	-	-	●	●	●	●	●
	Connection cable, M12, 4-pin, plug straight/socket straight, 1 m, PUR halogen free	DSL-1204-G01MC	6033244	-	-	●	●	●	●	●
	Connection cable, M12, 4-pin, plug straight/socket straight, 2 m, PUR halogen free	DSL-1204-G02MC	6025927	-	-	●	●	●	●	●
	Connection cable, M12, 4-pin, plug straight/socket straight, 5 m, PUR halogen free	DSL-1204-G05MC	6033245	-	-	●	●	●	●	●
	Connection cable, M12, 4-pin, plug straight/socket straight, 10 m, PUR halogen free	DSL-1204-G10MC	6033698	-	-	●	●	●	●	●





	Brief description	Model name	Part no.	WLG	HLG	ELG Short Range	ELG Long Range	ELG Long Range Relay	PLG3	PLG6
	Connection cable, M12, 5-pin, plug straight/socket straight, 1 m, PUR halogen free	DSL-1205-G01MC	6029280	●	-	-	-	●	-	-
	Connection cable, M12, 5-pin, plug straight/socket straight, 1.5 m, PUR halogen free	DSL-1205-G1M5C	6029281	●	-	-	-	●	-	-
	Connection cable, M12, 5-pin, plug straight/socket straight, 2 m, PUR halogen free	DSL-1205-G02MC	6025931	●	-	-	-	●	-	-
	Connection cable, M12, 5-pin, plug straight/socket straight, 5 m, PUR halogen free	DSL-1205-G05MC	6029282	●	-	-	-	●	-	-
	Connection cable, M12, 5-pin, plug straight/socket straight, 10 m, PUR halogen free	DSL-1205-G10MC	6038954	●	-	-	-	●	-	-
	Connection cable, M12, 8-pin, plug straight/socket straight, 1 m, PUR halogen free, shielded	DSL-1208-G01MAC	6026625	-	●	-	-	-	-	-
	Connection cable, M12, 8-pin, plug straight/socket straight, 2 m, PUR halogen free, shielded	DSL-1208-G02MAC	6030121	-	●	-	-	-	-	-
	Connection cable, M12, 8-pin, plug straight/socket straight, 5 m, PUR halogen free, shielded	DSL-1208-G05MAC	6032325	-	●	-	-	-	-	-
	Connection cable, M12, 8-pin, plug straight/socket straight, 10 m, PUR halogen free, shielded	DSL-1208-G10MAC	6034901	-	●	-	-	-	-	-
	Male connector, M12, 4-pin, straight	STE-1204-G	6009932	-	-	●	●	●	●	●







Reflectors

	Brief description	Model name	Part no.	WLG	HLG	ELG Short Range	ELG Long Range	ELG Long Range Relay	PLG3	PLG6
	Reflector, 18 mm x 150 mm, plastic, self-adhesive	PL150	5315548	●	-	-	-	-	●	●
	Reflector, 40 mm x 180 mm, plastic, 2-hole mounting	PL180E01	1013289	●	-	-	-	-	●	●
	Reflector, 40 mm x 60 mm, plastic, 2-hole mounting	PL40A	1012720	●	-	-	-	-	-	-
	Reflector, 80 mm x 80 mm, plastic, 2-hole mounting	PL80A	1003865	●	-	-	-	-	-	-
	Reflective tape, 749 mm x 914 mm sheet, self-adhesive	REF-DG	5320565	-	-	-	-	-	●	●
	Reflective tape, assembled, self-adhesive	REF-DG-K	4019634	-	-	-	-	-	●	●

E



	Brief description	Model name	Part no.	WLG	HLG	ELG Short Range	ELG Long Range	ELG Long Range Relay	PLG3	PLG6
	Reflective tape on aluminum profile for PLG, 16.5 mm x 124.3 mm, 2-hole mounting	REF-PLG060	1048996	-	-	-	-	-	-	●
	Reflective tape on aluminum profile for PLG, 16.5 mm x 194.3 mm, 2-hole mounting	REF-PLG120	1029196	-	-	-	-	-	●	-
	Reflective tape on aluminum profile for PLG, 16.5 mm x 274.3 mm, 2-hole mounting	REF-PLG210	1029197	-	-	-	-	-	●	-
	Reflective tape on aluminum profile for PLG, 16.5 mm x 344.3 mm, 2-hole mounting	REF-PLG270	1029198	-	-	-	-	-	●	-
	Reflective tape on aluminum profile for PLG, 16.5 mm x 424.3 mm, 2-hole mounting	REF-PLG360	1029199	-	-	-	-	-	●	-
	Reflective tape on aluminum profile for PLG, 16.5 mm x 494.3 mm, 2-hole mounting	REF-PLG420	1029200	-	-	-	-	-	●	-
	Reflective tape, cut to length, width 25 mm, roll length max. 22.8 m, self-adhesive	REF-PLUS-25-K	4051184	-	-	-	-	-	●	●

Terminal and alignment brackets

	Brief description	Model name	Part no.	WLG	HLG	ELG Short Range	ELG Long Range	ELG Long Range Relay	PLG3	PLG6
	Plate G for universal bar clamp, steel, zinc coated, incl. universal bar clamp and mounting material	BEF-KHS-G01	2022464	-	-	●	●	●	-	-
	Universal bar clamp, steel, zinc, die-cast	BEF-KHS-KH1	2022726	-	-	●	●	●	-	-
	Mounting rod, straight, 300 mm, steel, zinc coated, without mounting material	BEF-MS12G-B	4056055	-	-	●	●	●	-	-
	Mounting rod, straight, 200 mm, stainless steel, without mounting material	BEF-MS12G-NA	4058914	-	-	●	●	●	-	-
	Mounting rod, straight, 300 mm, stainless steel, without mounting material	BEF-MS12G-NB	4058915	-	-	●	●	●	-	-
	Mounting rod, L-shaped, 150 mm x 150 mm, steel, zinc coated, without mounting material	BEF-MS12L-A	4056052	-	-	●	●	●	-	-
	Mounting rod, L-shaped, 250 mm x 250 mm, steel, zinc coated, without mounting material	BEF-MS12L-B	4056053	-	-	●	●	●	-	-
	Mounting rod, L-shaped, 150 mm x 150 mm, stainless steel, without mounting material	BEF-MS12L-NA	4058912	-	-	●	●	●	-	-
	Mounting rod, L-shaped, 250 mm x 250 mm, stainless steel, without mounting material	BEF-MS12L-NB	4058913	-	-	●	●	●	-	-
	Mounting rod, L-shaped, 150 mm x 70 mm x 150 mm, steel, zinc coated, without mounting material	BEF-MS12Z-A	4056056	-	-	●	●	●	-	-
	Mounting rod, L-shaped, 150 mm x 70 mm x 250 mm, steel, zinc coated, without mounting material	BEF-MS12Z-B	4056057	-	-	●	●	●	-	-
	Mounting rod, L-shaped, 100 mm x 150 mm x 200 mm, steel, zinc coated, without mounting material	BEF-MS12Z-C	4064563	-	-	●	●	●	-	-
	Mounting rod, L-shaped, 150 mm x 70 mm x 150 mm, stainless steel, without mounting material	BEF-MS12Z-NA	4058916	-	-	●	●	●	-	-
	Mounting rod, L-shaped, 150 mm x 70 mm x 250 mm, stainless steel, without mounting material	BEF-MS12Z-NB	4058917	-	-	●	●	●	-	-
	Rod bar clamp for rod diameter of 12 mm, aluminum, 2 screws M6 x 30, 2 spring discs	BEF-RMC-D12	5321878	-	-	●	●	●	-	-

Smart light grids

Adapters/distributors (without cable)

	Brief description	Model name	Part no.	SAS	SPL	SGS
	Sensor/actuator box, 4x M12, 5-pin, cable, 5 m, PUR halogen free	SBL-04D12-KC05	6028394	-	●	-
	Sensor/actuator box, 8x M12, 5-pin, cable, 5 m, PUR halogen free	SBL-08D12-KC05	6028396	-	●	-







Cleaning agent

	Brief description	Model name	Part no.	SAS	SPL	SGS
	Plastic cleaner and care product, anti-static	Plastic cleaner	5600006	●	●	●









Lens cloths

	Brief description	Model name	Part no.	SAS	SPL	SGS
	-	Optical cleaning cloth	4003353	●	●	●



Plug connectors and cables

	Brief description	Model name	Part no.	SAS	SPL	SGS
 Illustration may differ	Female connector, M8, 4-pin, straight, 2 m, PVC	DOL-0804-G02M	6009870	●	●	●
	Female connector, M8, 4-pin, straight, 5 m, PVC	DOL-0804-G05M	6009872	●	●	●
	Female connector, M8, 4-pin, straight, 10 m, PVC	DOL-0804-G10M	6010754	●	●	●
	Female connector, M8, 4-pin, straight, 2 m, PUR halogen free	DOL-0804-G02MC	6025894	●	●	●
	Female connector, M8, 4-pin, straight, 5 m, PUR halogen free	DOL-0804-G05MC	6025895	●	●	●
	Female connector, M8, 4-pin, straight, 10 m, PUR halogen free	DOL-0804-G10MC	6025896	●	●	●
 Illustration may differ	Female connector, M8, 4-pin, angled, 2 m, PVC	DOL-0804-W02M	6009871	●	●	●
	Female connector, M8, 4-pin, angled, 5 m, PVC	DOL-0804-W05M	6009873	●	●	●
	Female connector, M8, 4-pin, angled, 10 m, PVC	DOL-0804-W10M	6010755	●	●	●
	Female connector, M8, 4-pin, angled, 2 m, PUR halogen free	DOL-0804-W02MC	6025897	●	●	●
	Female connector, M8, 4-pin, angled, 5 m, PUR halogen free	DOL-0804-W05MC	6025898	●	●	●
	Female connector, M8, 4-pin, angled, 10 m, PUR halogen free	DOL-0804-W10MC	6025899	●	●	●
 Illustration may differ	Female connector, M12, 4-pin, straight, 2 m, PVC	DOL-1204-G02M	6009382	●	●	●
	Female connector, M12, 4-pin, straight, 5 m, PVC	DOL-1204-G05M	6009866	●	●	●
	Female connector, M12, 4-pin, straight, 10 m, PVC	DOL-1204-G10M	6010543	●	●	●
	Female connector, M12, 4-pin, straight, 15 m, PVC	DOL-1204-G15M	6010753	●	●	●
	Female connector, M12, 4-pin, straight, 2 m, PUR halogen free	DOL-1204-G02MC	6025900	●	●	●
	Female connector, M12, 4-pin, straight, 5 m, PUR halogen free	DOL-1204-G05MC	6025901	●	●	●
	Female connector, M12, 4-pin, straight, 10 m, PUR halogen free	DOL-1204-G10MC	6025902	●	●	●
	Female connector, M12, 4-pin, straight, 15 m, PUR halogen free	DOL-1204-G15MC	6034749	●	●	●

E

	Brief description	Model name	Part no.	SAS	SPL	SGS
 Illustration may differ	Female connector, M12, 4-pin, angled, 2 m, PVC	DOL-1204-W02M	6009383	●	●	●
	Female connector, M12, 4-pin, angled, 5 m, PVC	DOL-1204-W05M	6009867	●	●	●
	Female connector, M12, 4-pin, angled, 10 m, PVC	DOL-1204-W10M	6010541	●	●	●
	Female connector, M12, 4-pin, angled, 2 m, PUR halogen free	DOL-1204-W02MC	6025903	●	●	●
	Female connector, M12, 4-pin, angled, 5 m, PUR halogen free	DOL-1204-W05MC	6025904	●	●	●
	Female connector, M12, 4-pin, angled, 10 m, PUR halogen free	DOL-1204-W10MC	6025905	●	●	●
	Female connector, M12, 4-pin, angled, 15 m, PUR halogen free	DOL-1204-W15MC	6034752	●	●	●
	Female connector, M8, 4-pin, straight	DOS-0804-G	6009974	●	●	●
	Female connector, M8, 4-pin, angled	DOS-0804-W	6009975	●	●	●
	Female connector, M12, 4-pin, straight	DOS-1204-G	6007302	●	●	●
	Female connector, M12, 4-pin, angled	DOS-1204-W	6007303	●	●	●
 Illustration may differ	Connection cable, M12, 4-pin, plug straight/socket straight, 1.5 m, PVC	DSL-1204-G1M5	6034822			
	Connection cable, M12, 4-pin, plug straight/socket straight, 2 m, PVC	DSL-1204-G02M	6022567	●	●	●
	Connection cable, M12, 4-pin, plug straight/socket straight, 5 m, PVC	DSL-1204-G05M	6022569	●	●	●
	Connection cable, M12, 4-pin, plug straight/socket straight, 10 m, PVC	DSL-1204-G10M	6034406	●	●	●
	Connection cable, M12, 4-pin, plug straight/socket straight, 20 m, PVC	DSL-1204-G20M	6034407	-	-	●
	Connection cable, M12, 4-pin, plug straight/socket straight, 1 m, PUR halogen free	DSL-1204-G01MC	6033244	●	●	●
	Connection cable, M12, 4-pin, plug straight/socket straight, 2 m, PUR halogen free	DSL-1204-G02MC	6025927	●	●	●
	Connection cable, M12, 4-pin, plug straight/socket straight, 5 m, PUR halogen free	DSL-1204-G05MC	6033245	●	●	●
	Connection cable, M12, 4-pin, plug straight/socket straight, 10 m, PUR halogen free	DSL-1204-G10MC	6033698	●	●	●
 Illustration may differ	Connection cable, M8/M12, 4-pin, plug straight/socket straight, 2 m, PVC	DSL-8204-G02M	6022573	●	●	●
	Connection cable, M8/M12, 4-pin, plug straight/socket straight, 5 m, PVC	DSL-8204-G05M	6034403	●	●	●
	Connection cable, M8/M12, 4-pin, plug straight/socket straight, 10 m, PVC	DSL-8204-G10M	6034404	●	●	●

Terminal and alignment brackets

	Brief description	Model name	Part no.	SAS	SPL	SGS
	Mounting bracket for mounting on the face sides. The mounting kit consists of 2x BEF-SLG1 and 2x BEF-SLG2.	BEF-SLG-SET1	2055427	●	●	●
	Mounting bracket for mounting on the face sides. The mounting kit consists of 4x BEF-SLG1.	BEF-SLG-SET2	2056518	●	●	●
	Bracket for SLG, stainless steel, 4 pcs	VZA-SLG	2048519	●	●	●

Dimensional drawings

Adapters/distributors (without cable)

ADAPT-PB-GE-MLG

Dimensional drawing

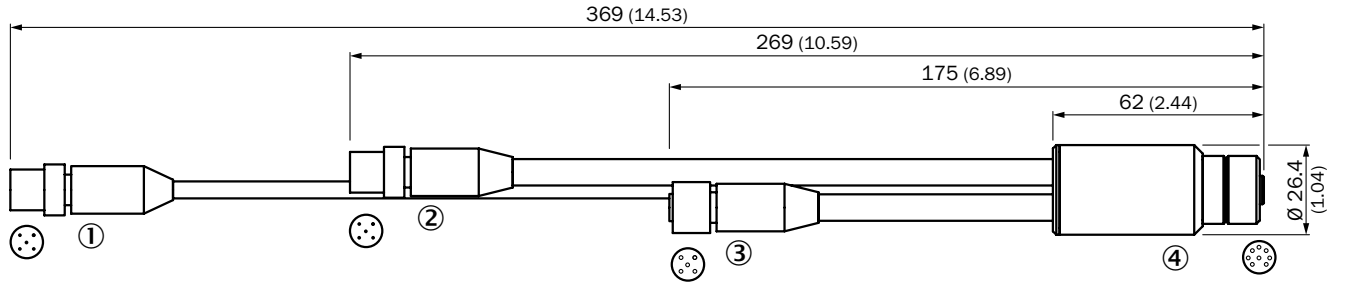

All dimensions in mm (inch)

- ① MLG connection
- ② PROFIBUS OUT M12, 5-pin
- ③ PROFIBUS IN M12, 5-pin
- ④ MLG receiver

Connection type

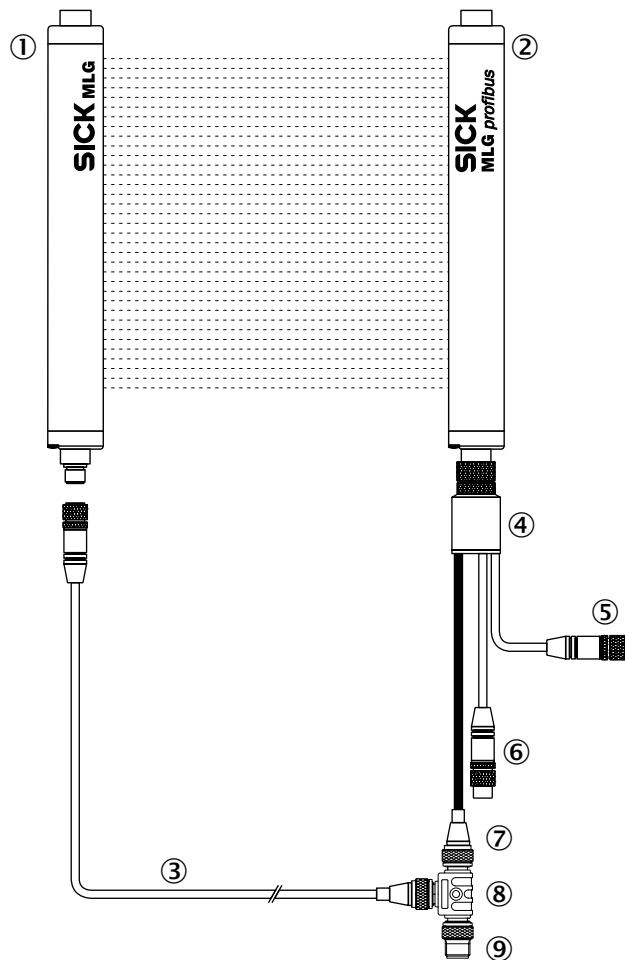

- ① MLG sender
- ② MLG receiver
- ③ Connection cable
- ④ PROFIBUS adapter straight
- ⑤ PROFIBUS IN M12, 5-pin
- ⑥ PROFIBUS OUT M12, 5-pin
- ⑦ MLG connection
- ⑧ Supply Q1

E

Connection diagram

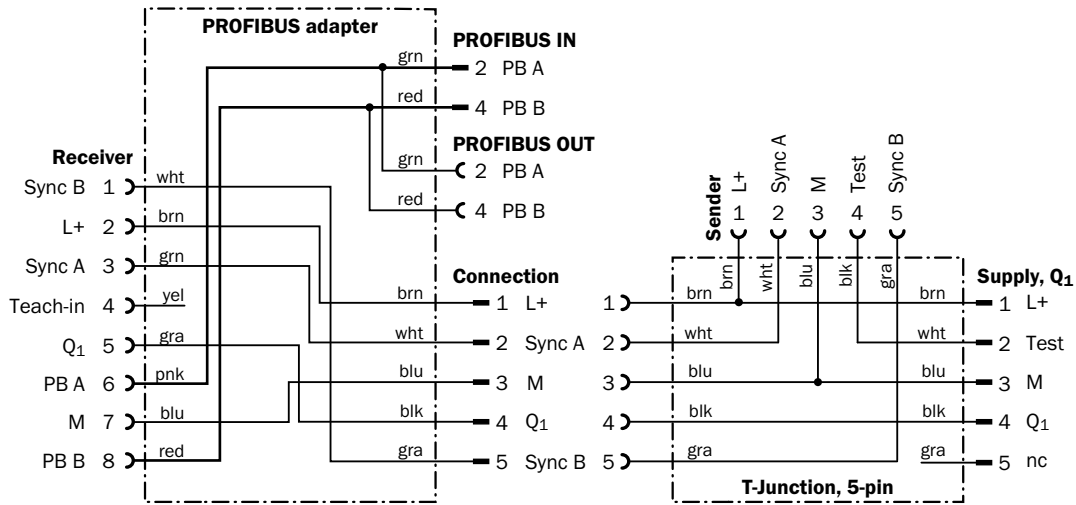

ADAPT-PB-WI-MLG

Dimensional drawing

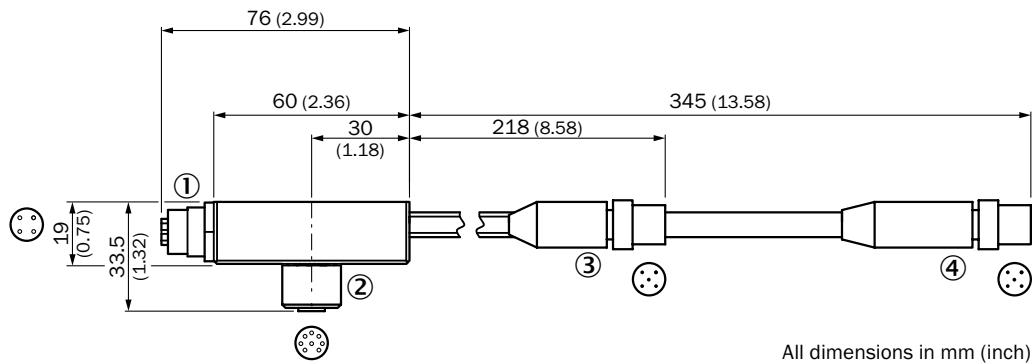

- ① PROFIBUS OUT M12, 5-pin
- ② MLG receiver
- ③ MLG connection
- ④ PROFIBUS IN M12, 5-pin

Connection type

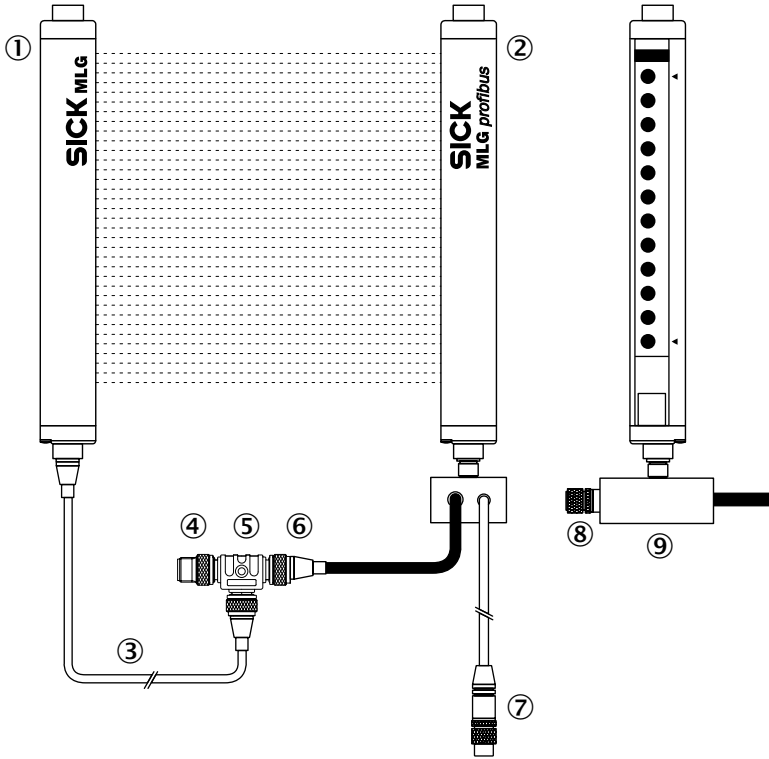

- ① MLG sender
- ② MLG receiver
- ③ Connection cable
- ④ Supply Q1
- ⑤ T-piece
- ⑥ MLG connection
- ⑦ PROFIBUS IN
- ⑧ PROFIBUS OUT
- ⑨ PROFIBUS adapter angled

Connection diagram

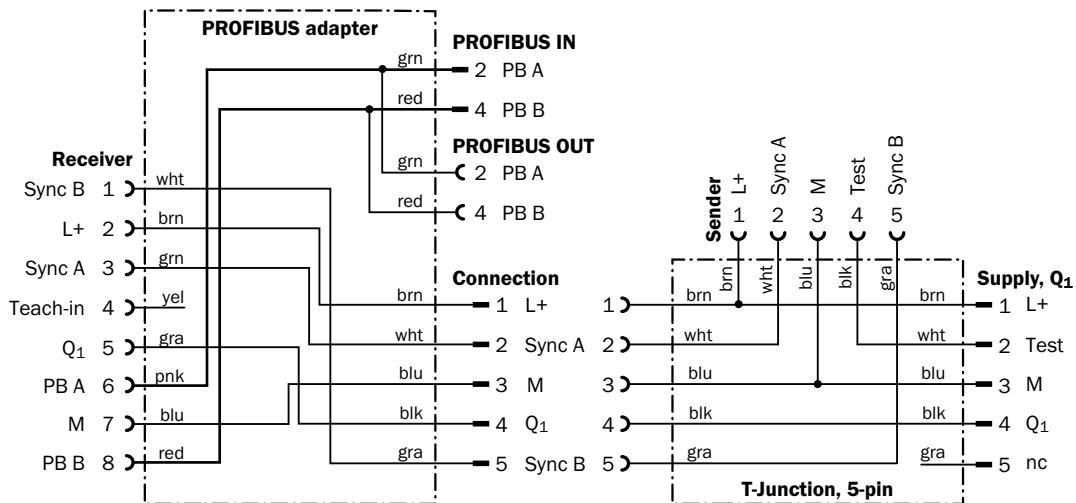

E

ADPT-CAN-GE-MLG

Dimensional drawing

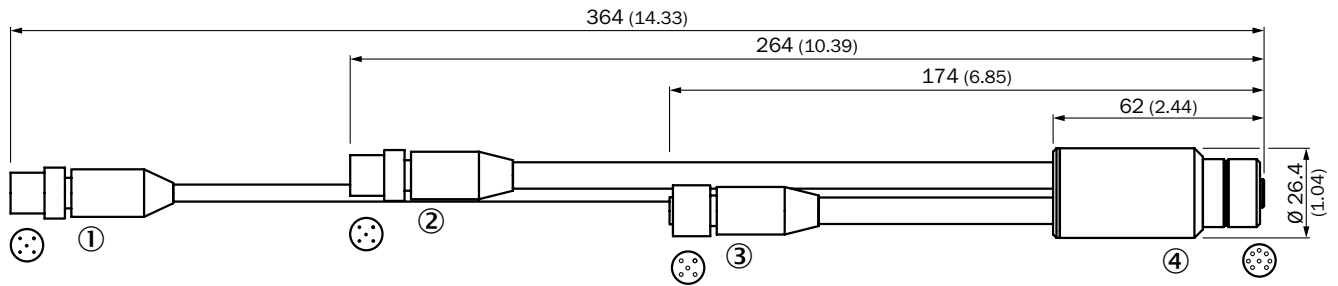

All dimensions in mm (inch)

- ① MLG connection M12, 8-pin
- ② CANopen IN M12, 5-pin
- ③ CANopen OUT M12, 5-pin
- ④ MLG receiver

Connection type

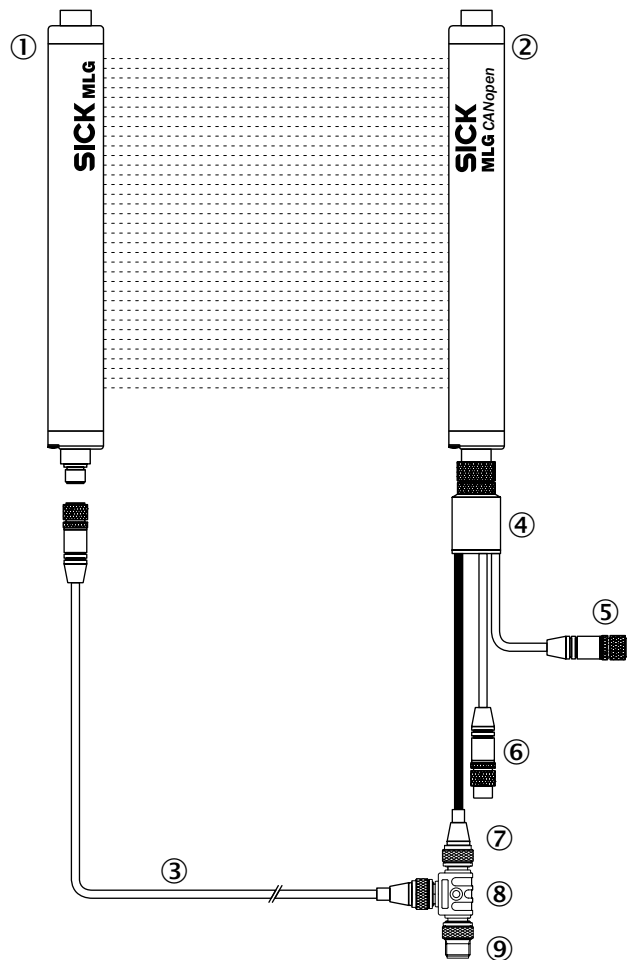

- ① MLG sender
- ② MLG receiver
- ③ Connection cable
- ④ CANopen adapter straight
- ⑤ CANopen OUT M12, 5-pin
- ⑥ CANopen IN M12, 5-pin
- ⑦ MLG connection
- ⑧ T-piece
- ⑨ Supply Q1

Connection diagram

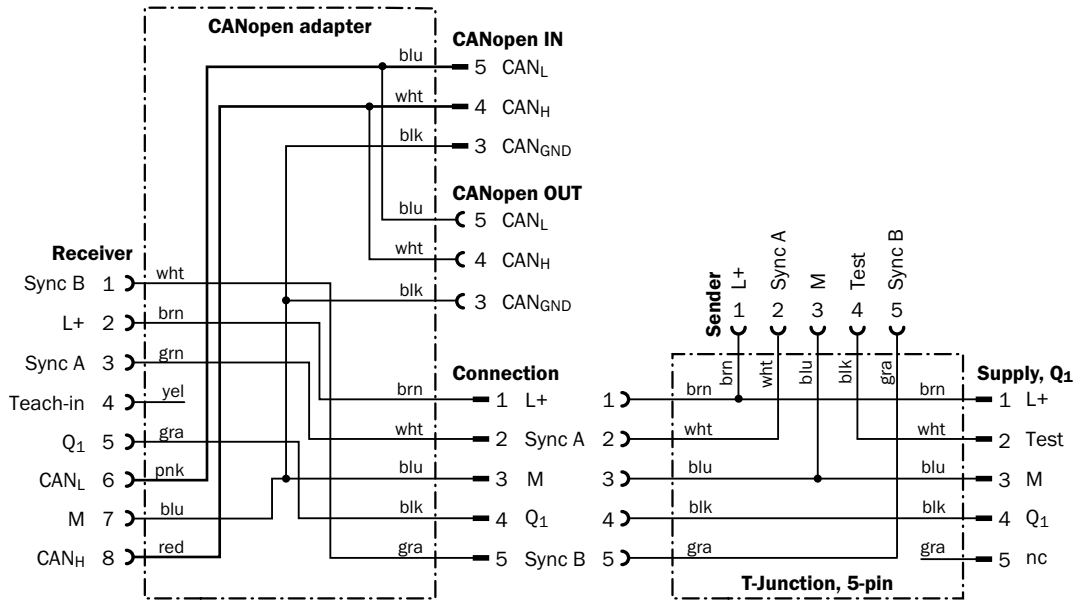

SBL-04D12-KC05

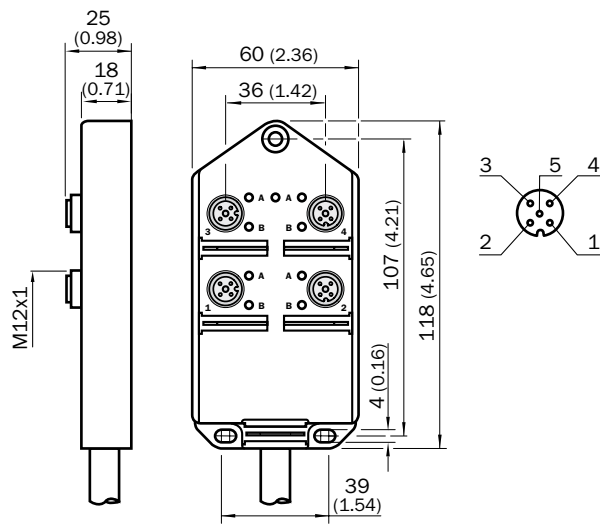

Dimensions in mm (inch)

SBL-08D12-KC05

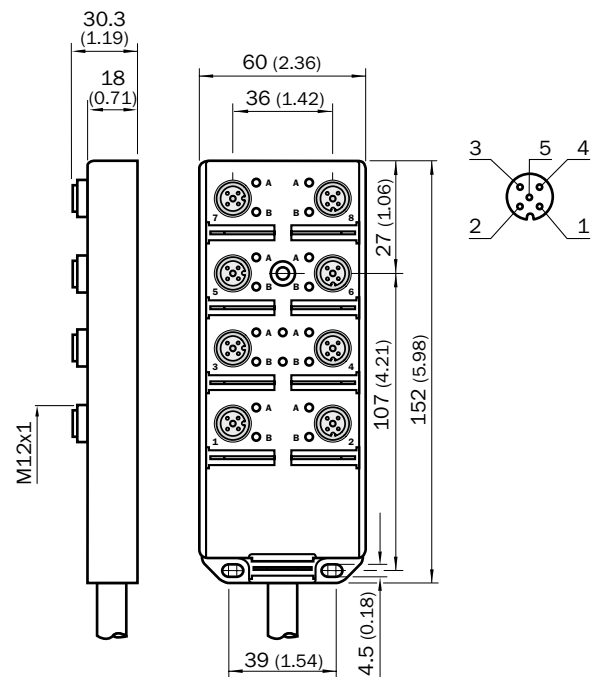

Dimensions in mm (inch)



SB0-02F12-SM

Dimensional drawing

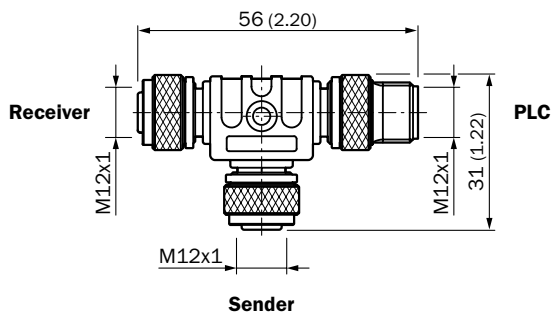

All dimensions in mm (inch)

Connection type

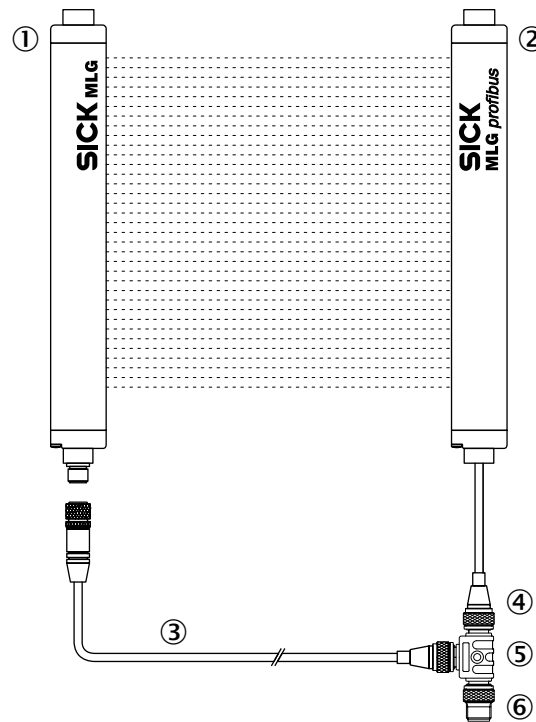

- ① MLG sender
- ② MLG receiver
- ③ Connection cable
- ④ MLG connection
- ⑤ T-piece
- ⑥ Supply Q1

Connection diagram

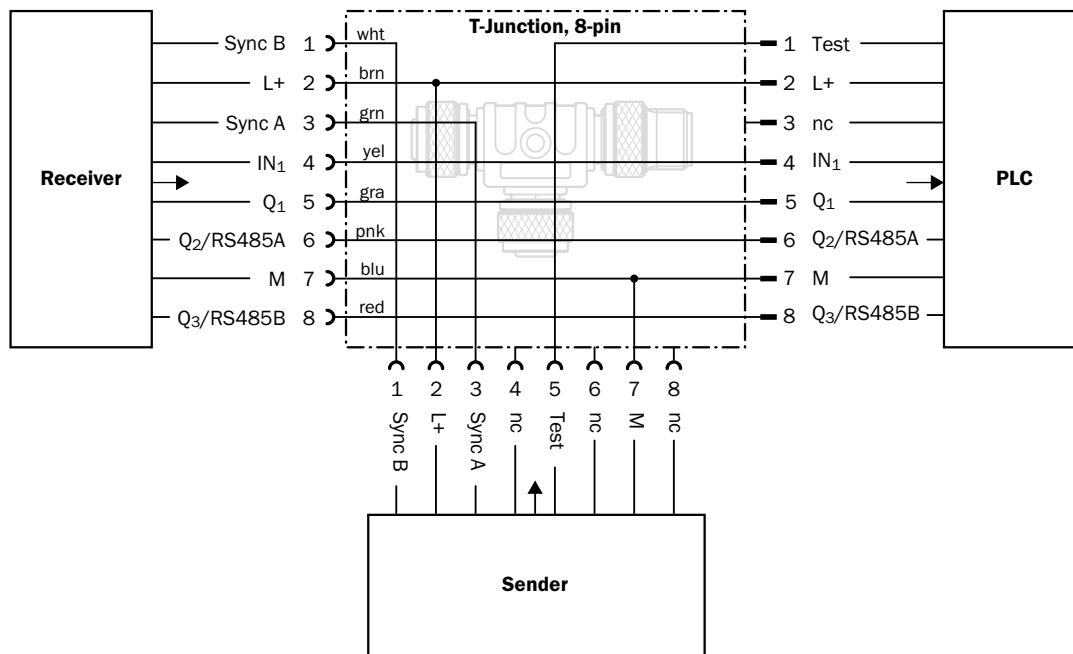

SBO-02G12-SM

Dimensional drawing

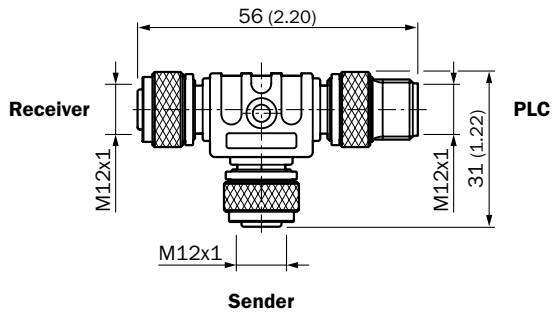

All dimensions in mm (inch)

Connection diagram

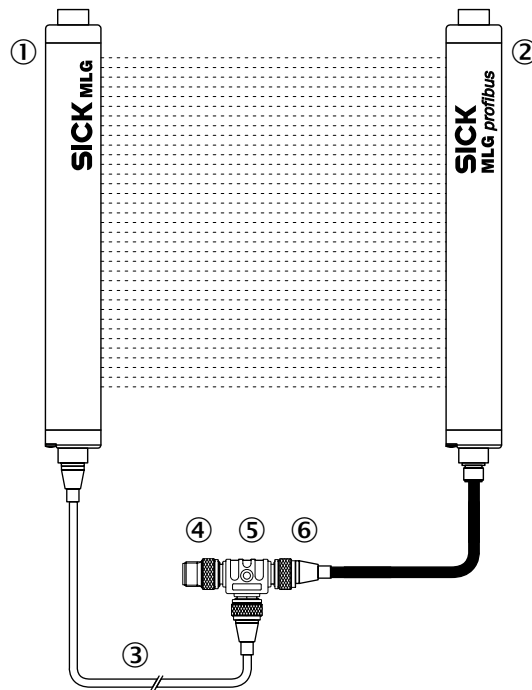

- ① MLG sender
- ② MLG receiver
- ③ Connection cable
- ④ Supply Q1
- ⑤ T-piece
- ⑥ MLG connection

SYL-1205-G0M3

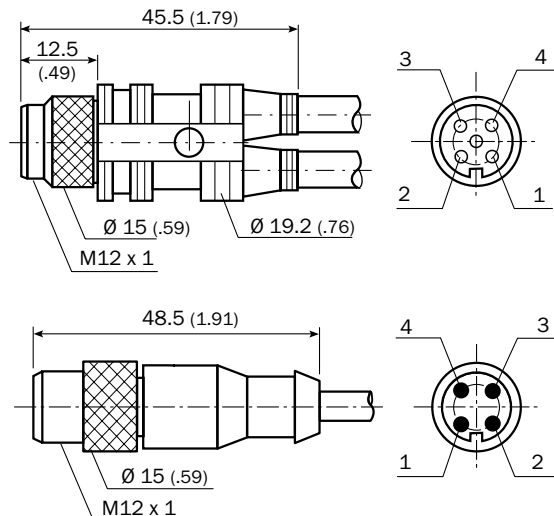

All dimensions in mm (inch)

E

Mounting brackets/plates

BEF-1SHABAAL4

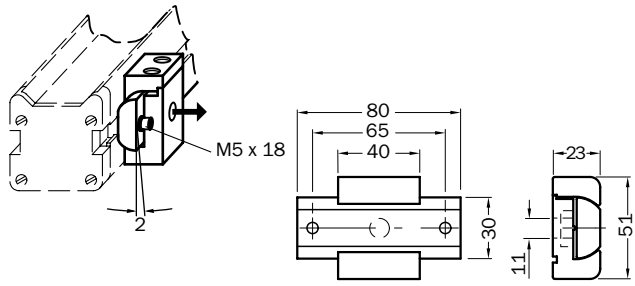

All dimensions in mm

BEF-2SMKEAAL2
BEF-2SMKEAAL4

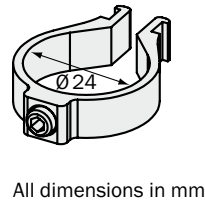

All dimensions in mm

BEF-2SMKEAES4

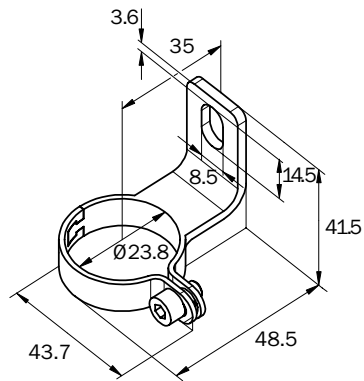

All dimensions in mm

BEF-2SMKEAKU4

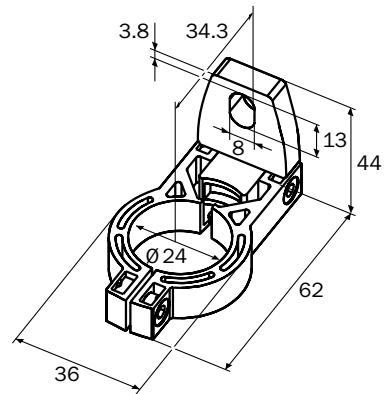

All dimensions in mm

BEF-3WNGBAST4

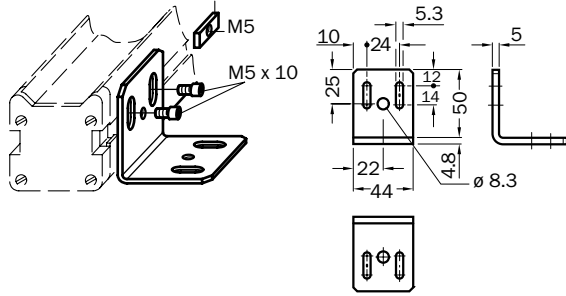

All dimensions in mm

BEF-RD30-PLG

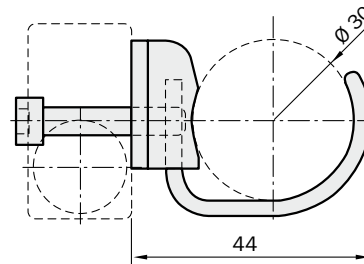
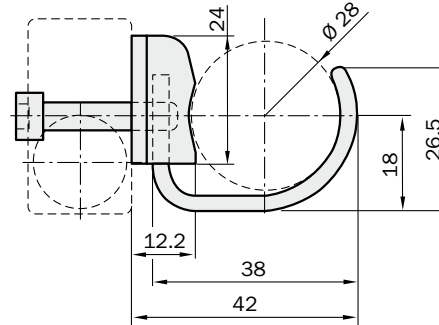
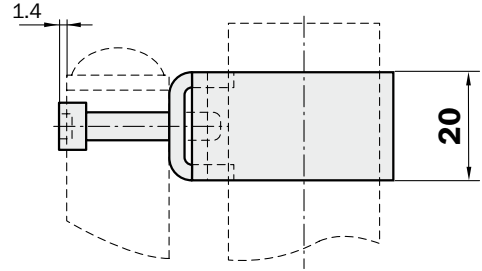

All dimensions in mm

BEF-WN-WLG12

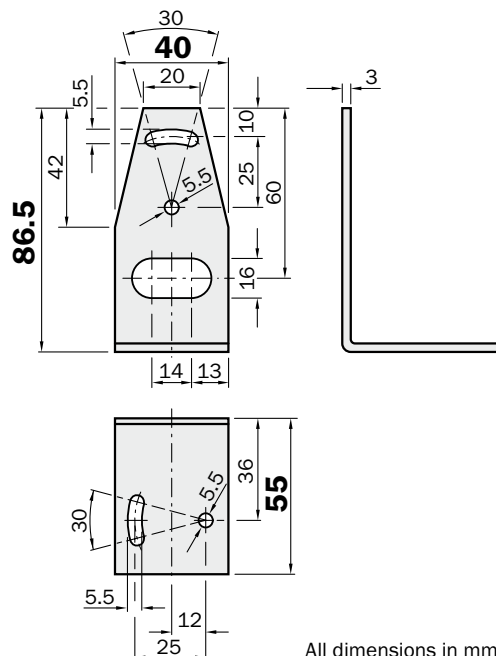

All dimensions in mm



BEF-NUT-MLG

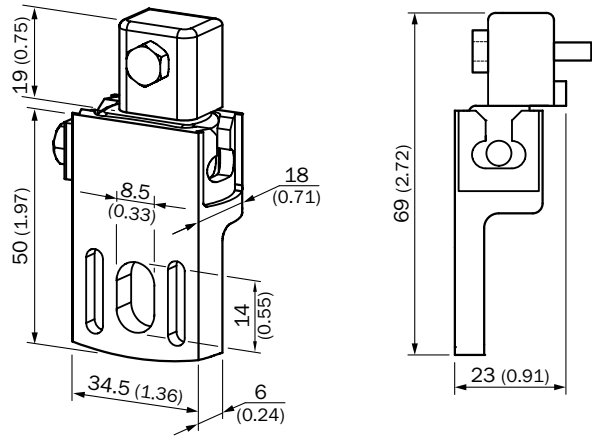

All dimensions in mm (inch)

BEF-WK-XLG

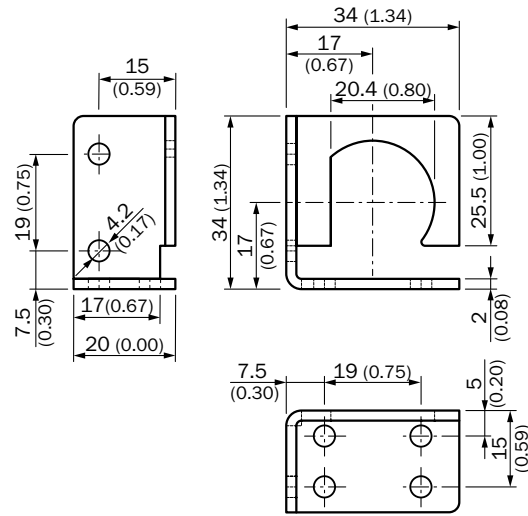

All dimensions in mm (inch)

Plug connectors and cables

- DOL-0804-G02MC**
- DOL-0804-G05MC**
- DOL-0804-G10MC**

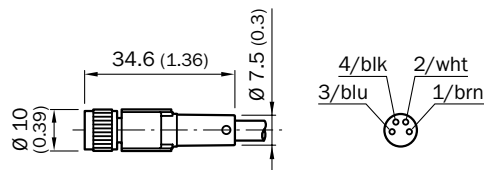

Dimensions in mm (inch)

- DOL-0804-W02MC**
- DOL-0804-W05MC**
- DOL-0804-W10MC**

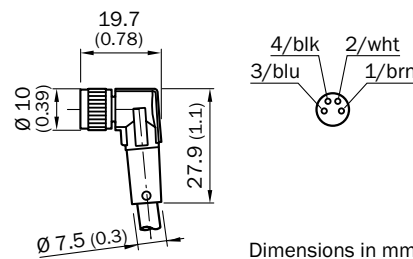

Dimensions in mm (inch)

- DOL-0804-G02M**
- DOL-0804-G05M**
- DOL-0804-G10M**

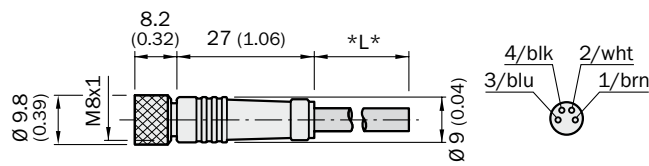

All dimensions in mm (inch)

- DOL-0804-W02M**
- DOL-0804-W05M**
- DOL-0804-W10M**

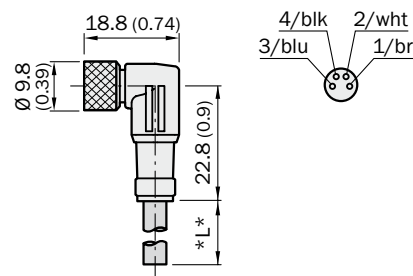

All dimensions in mm (inch)

DOL-1204-G02M/DOL-1204-G02MC
DOL-1204-G05M/DOL-1204-G05MC
DOL-1204-G10M/DOL-1204-G10MC
DOL-1204-G15M/DOL-1204-G15MC

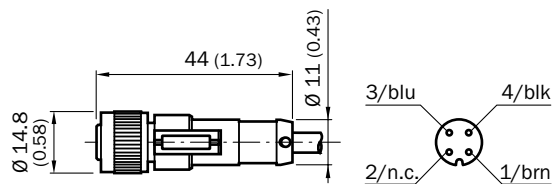

Dimensions in mm (inch)

DOL-1204-W02M
DOL-1204-W05M
DOL-1204-W10M

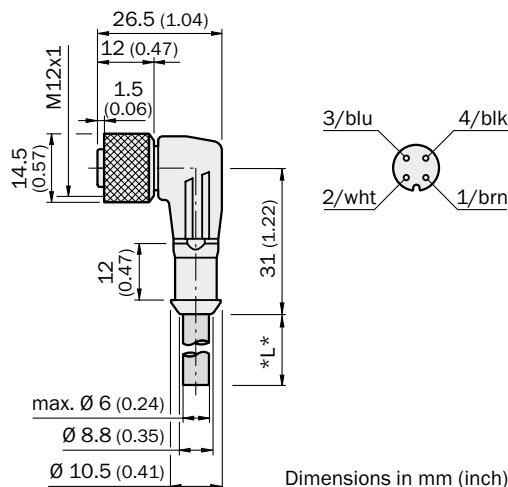

Dimensions in mm (inch)

DOL-1204-W02MC/DOL-1204-W05MC
DOL-1204-W10MC/DOL-1204-W15MC

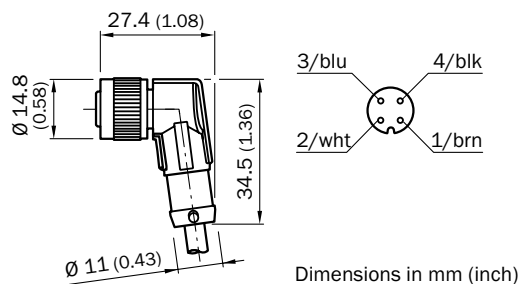

Dimensions in mm (inch)

DOL-1205-G02M/DOL-1205-G05M
DOL-1205-G10M/DOL-1205-G15M

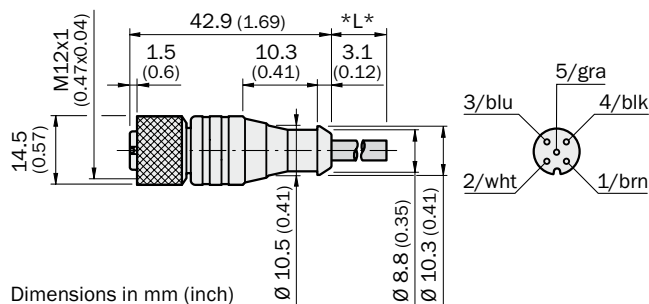

Dimensions in mm (inch)

DOL-1205-G02MC
DOL-1205-G05MC
DOL-1205-G10MC

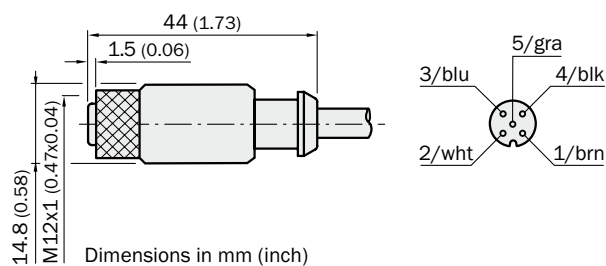

Dimensions in mm (inch)

DOL-1205-G02MN
DOL-1205-G05MN
DOL-1205-G10MN

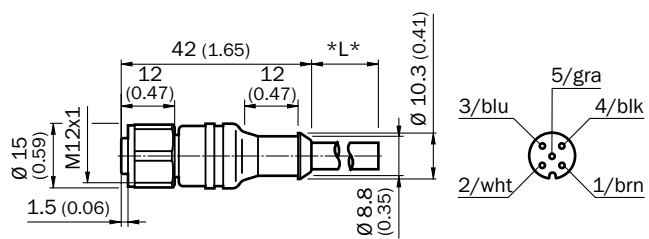

Dimensions in mm (inch)



DOL-1205-G05MQ
DOL-1205-G10MQ
DOL-1205-G12MQ

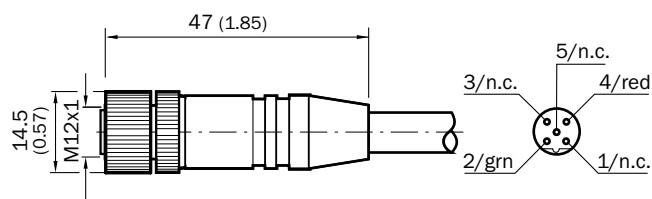

All dimensions in mm (inch)

DOL-1205-G10MAC

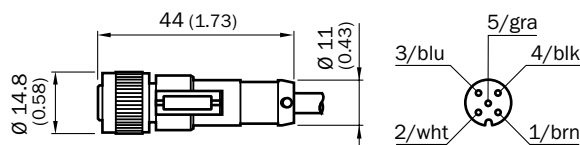

All dimensions in mm (inch)

DOL-1205-G06MK

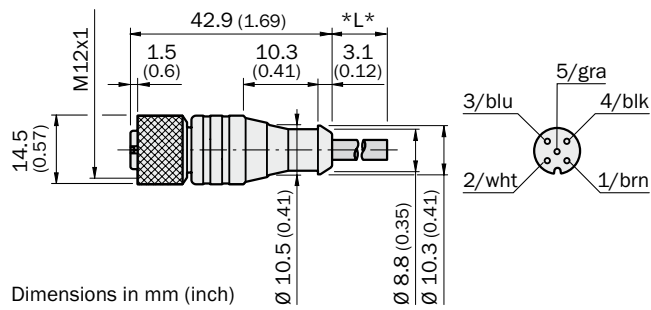

Dimensions in mm (inch)

DOL-1205-W02M
DOL-1205-W05M
DOL-1205-W10M

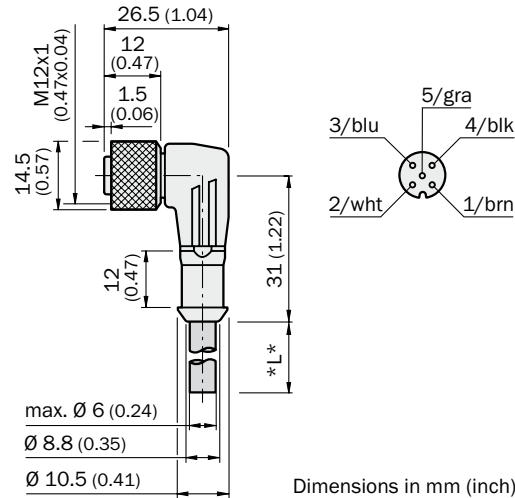

Dimensions in mm (inch)

DOL-1205-W02MC
DOL-1205-W05MC
DOL-1205-W10MC

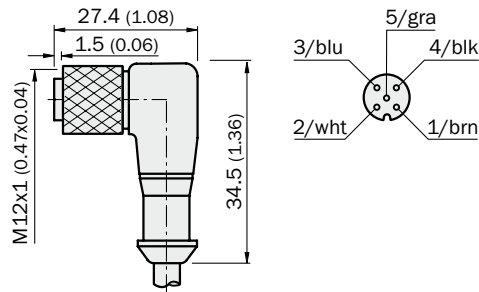

Dimensions in mm (inch)

DOL-1208-G02MA/DOL-1208-G05MA
DOL-1208-G10MA/DOL-1208-G10MAC
DOL-1208-G15MA

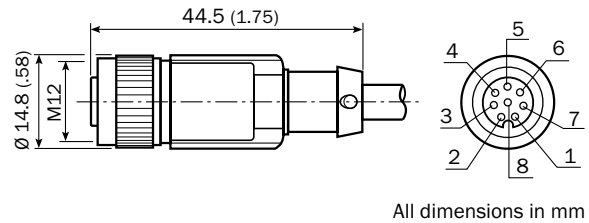

All dimensions in mm

DOL-1208-G05MACR

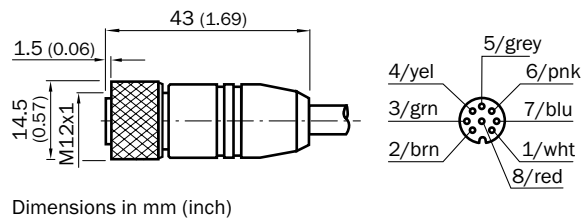

Dimensions in mm (inch)

DOL-1208-W02MA
DOL-1208-W05MA

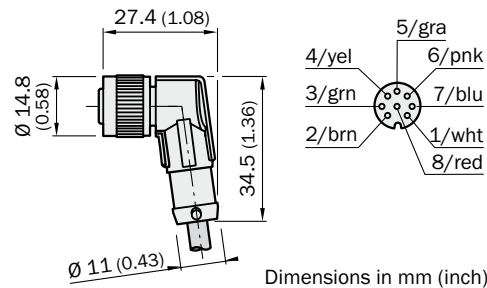

Dimensions in mm (inch)

DOL-1208-W10MAC

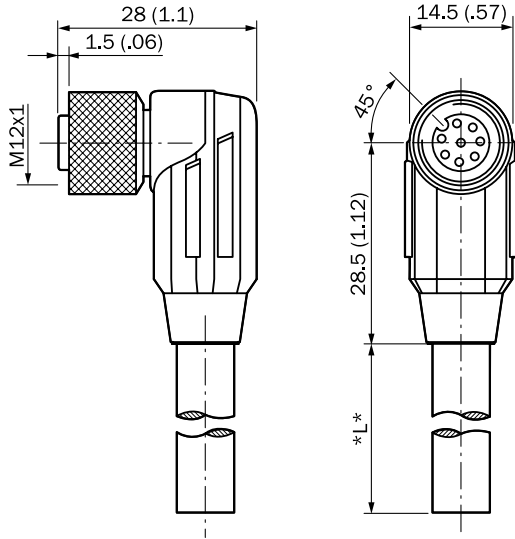

All dimensions in mm (inch)

DOL-1212-G02MA
DOL-1212-G05MA

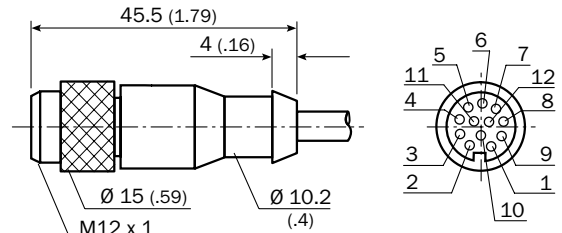

All dimensions in mm (inch)

DOS-0804-G

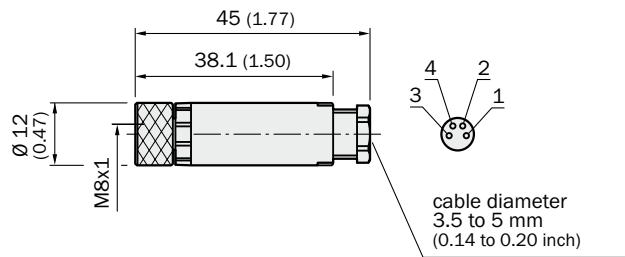

All dimensions in mm (inch)

DOS-0804-W

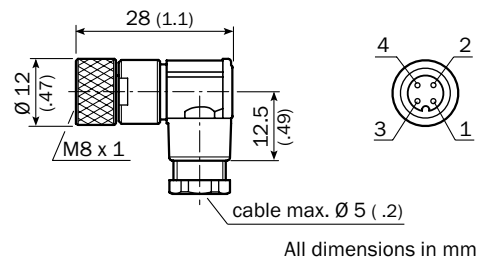

All dimensions in mm

DOS-1204-G

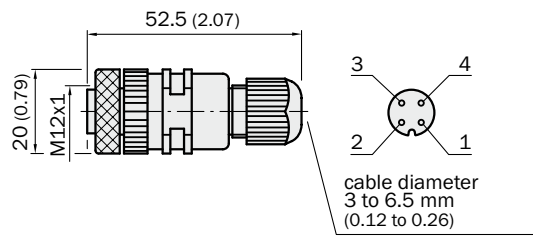

Dimensions in mm (inch)

DOS-1204-W

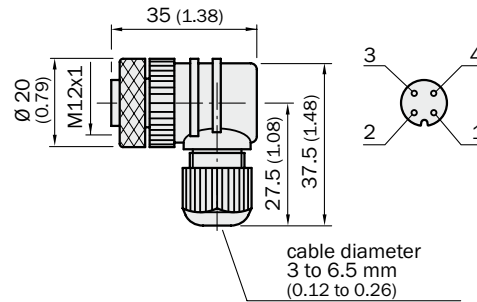

Dimensions in mm (inch)



DOS-1205-G

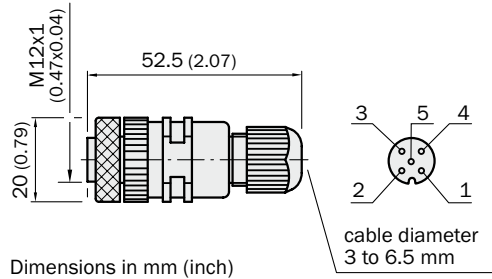

DOS-1205-W

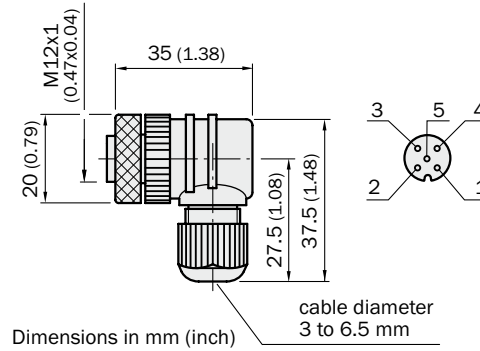

DOS-1208-GA

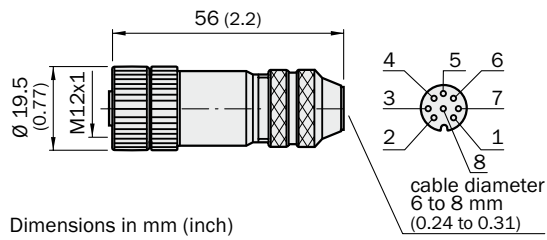

DOS-1208-WA

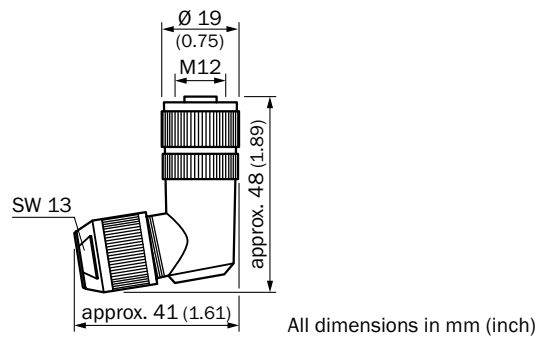

**DSL-8204-G02M/DSL-8204-G05M
DSL-8204-G10M**

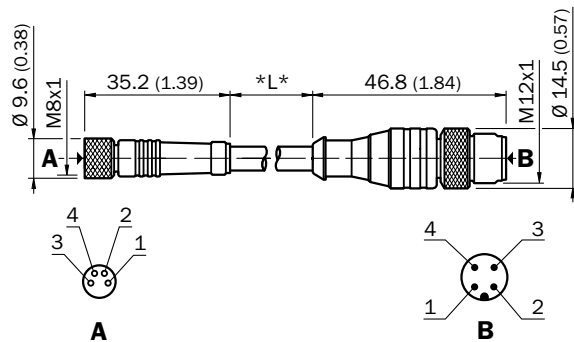

DSL-8D04-G02M

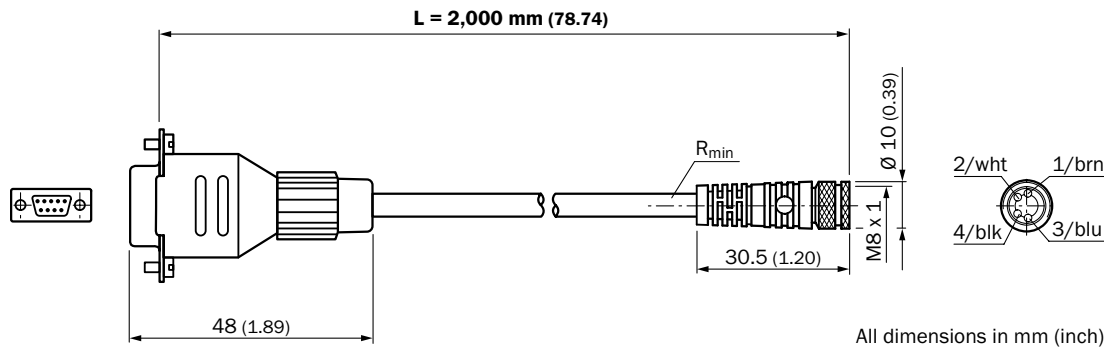

DSL-1204-G01MC/DSL-1204-G02MC
DSL-1204-G05MC/DSL-1204-G10MC

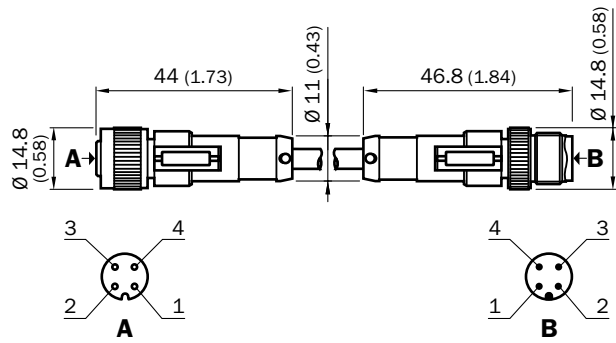

Dimensions in mm (inch)

DSL-1204-G0M6/DSL-1204-G1M5
DSL-1204-G02M/DSL-1204-G05M
DSL-1204-G10M/DSL-1204-G20M

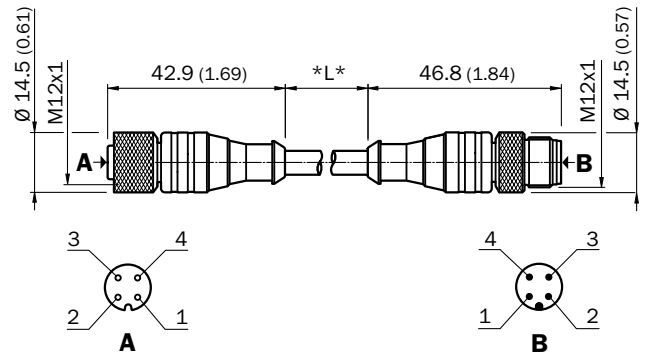

Dimensions in mm (inch)

DSL-1205-G01MC/DSL-1205-G1M5C
DSL-1205-G02MC/DSL-1205-G05MC
DSL-1205-G10MC

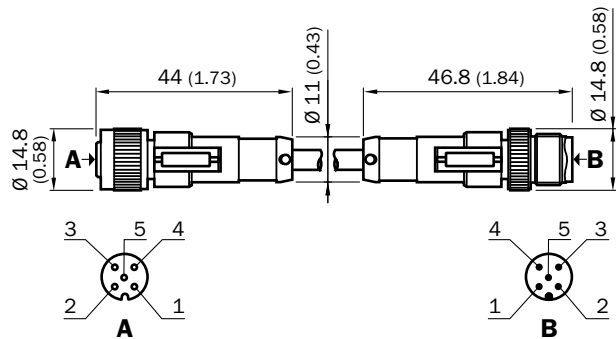

Dimensions in mm (inch)

DSL-1205-G01MK
DSL-1205-G06MK

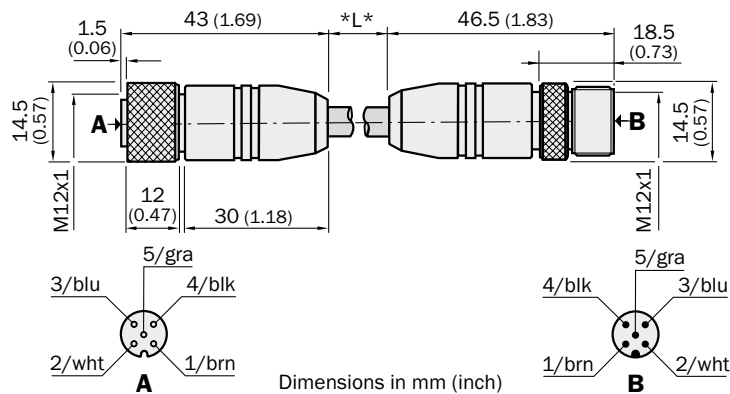

Dimensions in mm (inch)

E

DSL-1205-G10MQ

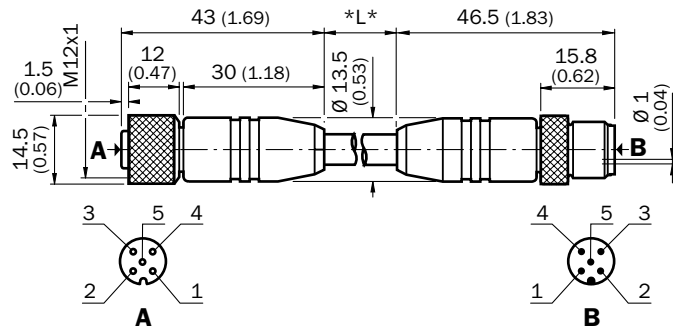

Dimensions in mm (inch)

**DSL-1208-G01MAC/DSL-1208-G02MAC
DSL-1208-G05MAC/DSL-1208-G10MAC**

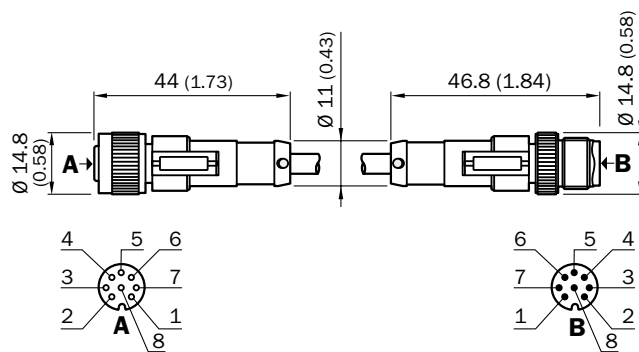

Dimensions in mm (inch)

PR-DOS-1205-G

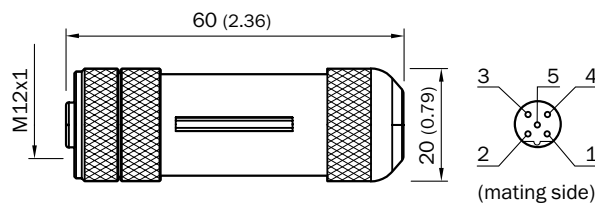

All dimensions in mm (inch)

PR-STE-1205-G

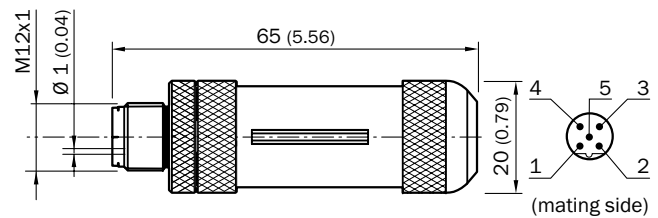

All dimensions in mm (inch)

STE-1204-G

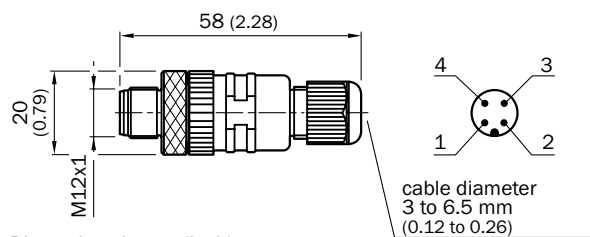

Dimensions in mm (inch)

STE-1205-G

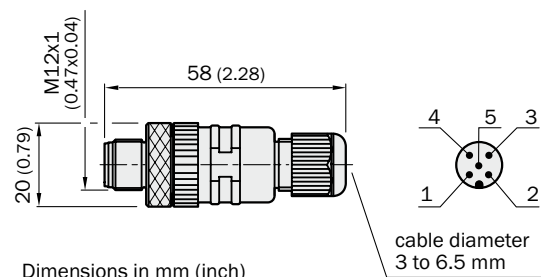

Dimensions in mm (inch)

STE-1205-GA

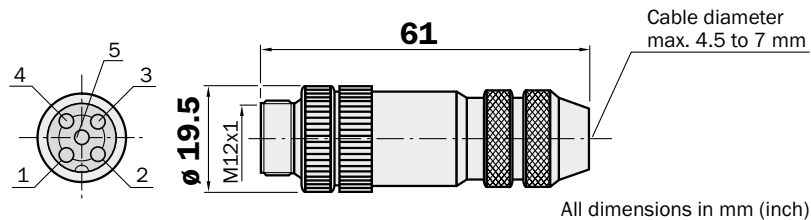

STE-1205-GKEND

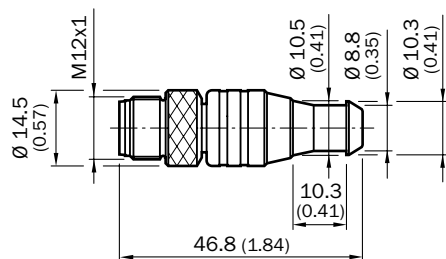

**STL-1205-G05MQ/STL-1205-G10MQ
STL-1205-G12MQ/STL-1205-G15MQ**

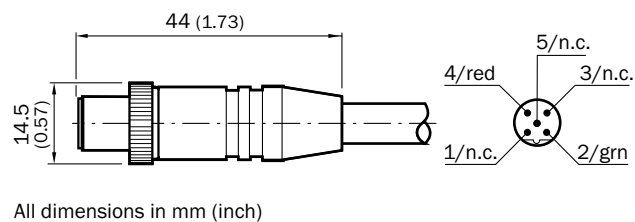

Reflectors

PL150

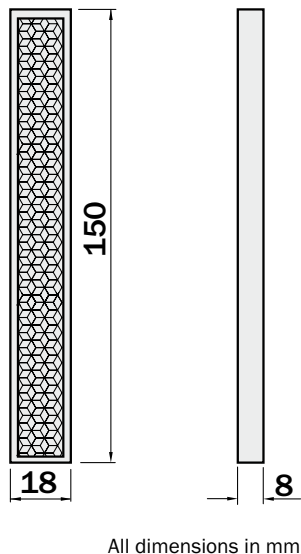

PL180E01

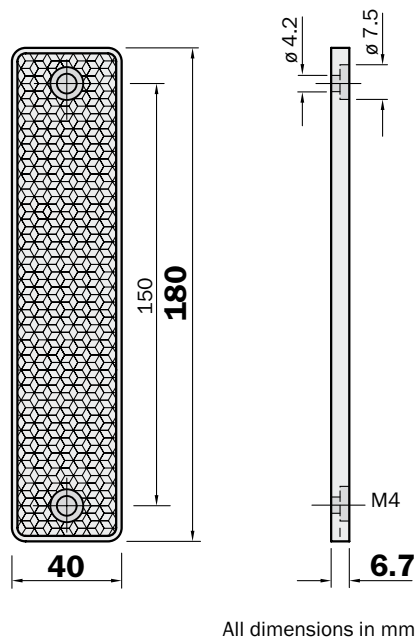

PL40A

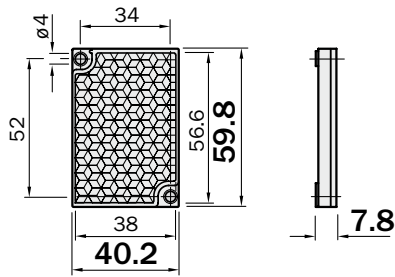

All dimensions in mm

PL80A

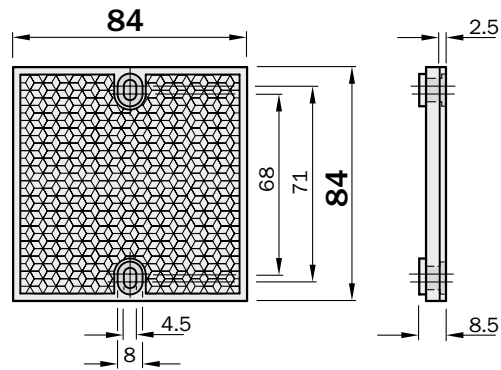

All dimensions in mm

REF-DG

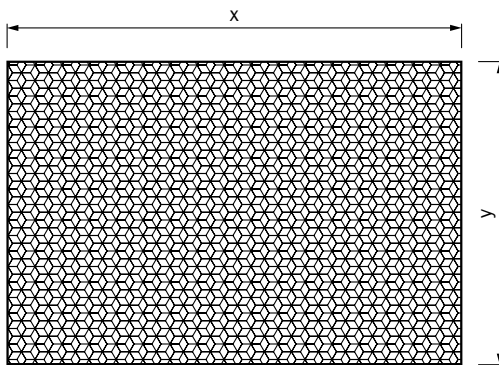

REF-DG-K

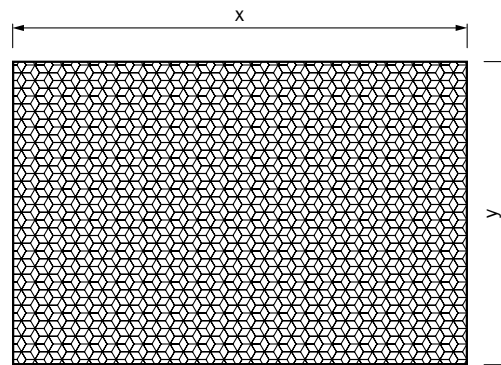

REF-PLG060/REF-PLG120
REF-PLG210/REF-PLG270
REF-PLG360/REF-PLG420

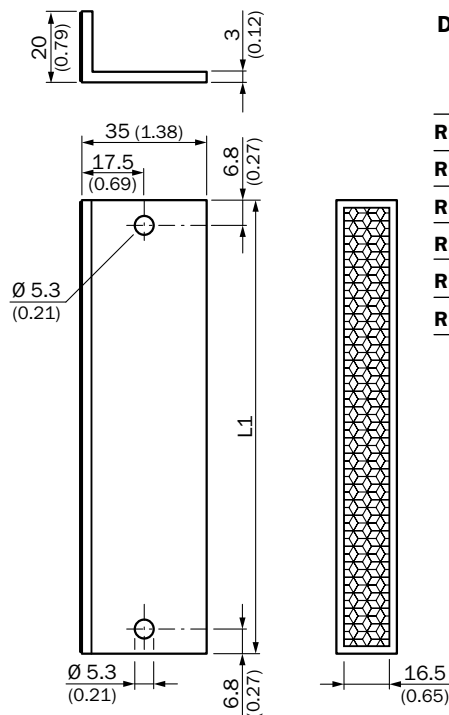

Dimensions in mm (inch)

L1

REF-PLG060	124.3 (4.89)
REF-PLG120	194.3 (7.65)
REF-PLG210	274.3 (10.79)
REF-PLG270	344.3 (13.56)
REF-PLG360	424.3 (16.70)
REF-PLG420	494.3 (19.46)

All dimensions in mm (inch)

REF-PLUS-25-K

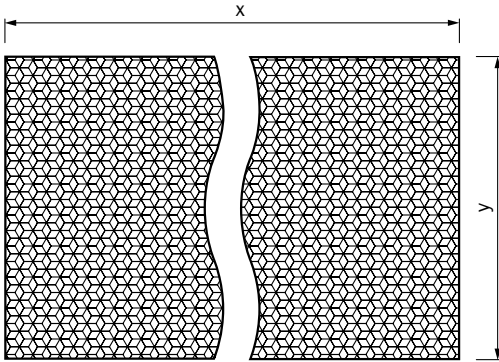

Terminal and alignment brackets

BEF-SLG-SET1

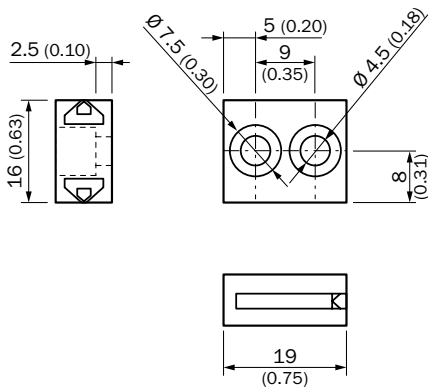

All dimensions in mm (inch)

BEF-SLG-SET2

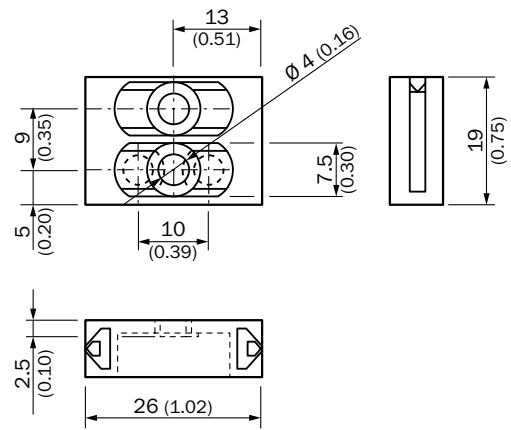

All dimensions in mm (inch)

VZA-SLG

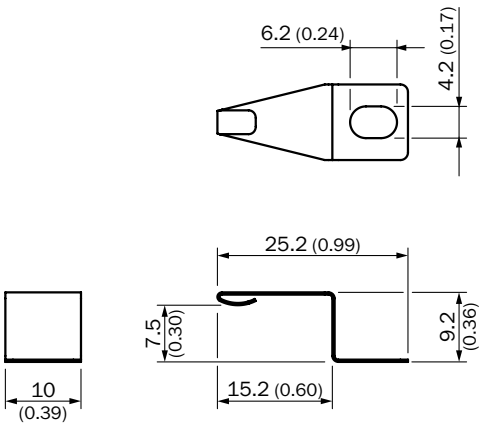

All dimensions in mm (inch)



BEF-KHS-G01

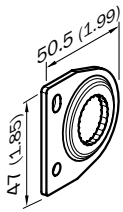

All dimensions in mm (inch)

- BEF-MS12G-B (size A = 300 mm)**
- BEF-MS12G-NA (size A = 200 mm)**
- BEF-MS12G-NB (size A = 300 mm)**

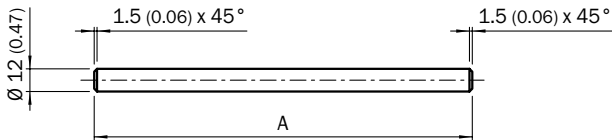

All dimensions in mm (inch)

- BEF-MS12Z-A (size A/C = 150 mm, B = 70 mm)**
- BEF-MS12Z-B (size A = 150 mm, B = 70 mm, C = 250 mm)**
- BEF-MS12Z-C (size A = 100 mm, B = 150 mm, C = 200 mm)**
- BEF-MS12Z-NA (size A/C = 150 mm, B = 70 mm)**
- BEF-MS12Z-NB (size A = 150 mm, B = 70 mm, C = 250 mm)**

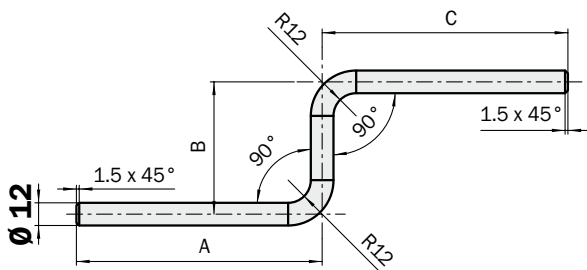

All dimensions in mm

BEF-KHS-KH1

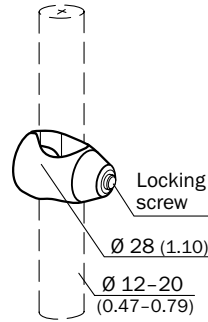

All dimensions in mm (inch)

- BEF-MS12L-A (size A/B = 150 mm)**
- BEF-MS12L-B (size A/B = 250 mm)**
- BEF-MS12L-NA (size A/B = 150 mm)**
- BEF-MS12L-NB (size A/B = 250 mm)**

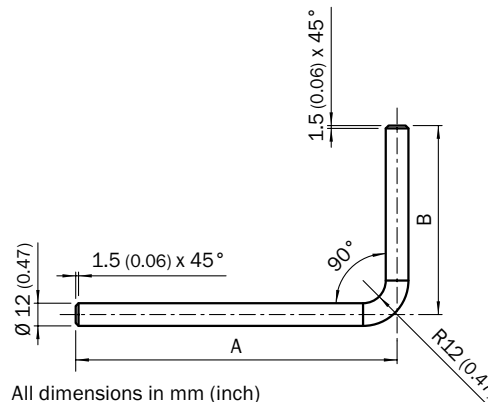

All dimensions in mm (inch)

BEF-RMC-D12

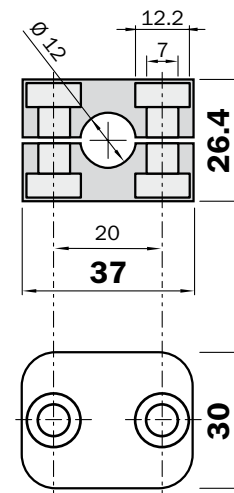

All dimensions in mm



Compact info: important information about SICK sensor solutions

The following pages contain explanations of key terminology in a concise, easy-to-read form, from A for abbreviation to V for vibration resistance. Definitions of all key terms related to SICK's innovations and sensor solutions can be found here.

This glossary also provides valuable information about directives and standards such as conformity, protection classes, laser classes and much more.

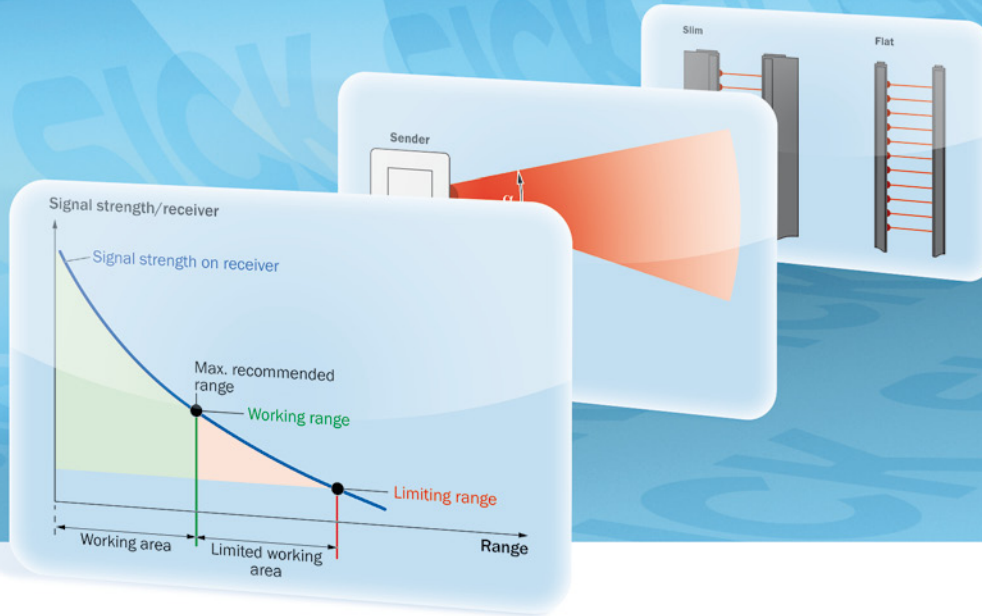

Appendix

Glossary F-2

A

Abbreviations for light grids/light grid families

Abbreviations for light grids are indicative of certain product properties. Explanations are as follows:

- ALG – Automation light grid
- MLG – Modular light grid
- XLG – Extremely sunlight-resistant light grid
- WLG – Modulated light light grid
- HLG – High-resolution light grid
- ELG – Economic light grid
- PLG – Pick-to-light light grid
- SLG – Smart light grid
- SAS – Smart area sensor
- SGS – Smart gate sensor
- SPL – Smart-pick-to-light light grid

Alarm output

► see output weak signal on page F-6

Alignment aid

An alignment aid, either external or integrated, helps to mutually align light grids and makes commissioning of light grids much simpler. A laser alignment aid is available as an accessory.

Ambient light safety

Light grids evaluate the light they emit and receive to determine object detection. At the same time, other light sources ranging from the sun to high-frequency radiation sources emit light too. This is known as ambient light. This light should not be allowed to affect how opto-electronic devices function, otherwise ALGs may switch incorrectly. A key requirement of users is therefore maximum ambient light safety, especially to high-frequency lights or strobe warning lamps, without any reduction of the performance of opto-electronic sensors.

Ambient temperature

The maximum ambient temperature is the highest permissible ambient air temperature at which full functional capability of the sensor is still guaranteed.

The minimum operating temperature is the lowest permissible ambient air temperature at which full functional capability of the sensor is still guaranteed.

Analog output

An analog output may be understood as an electrical output designed as a voltage or current output e.g. for simple height measurement.

Aperture angle

The aperture angle is the divergence of the light beam generated by the sender. A large aperture angle enables very simple alignment of the sender unit to the receiver unit, a smaller aperture angle reduces reflection problems.

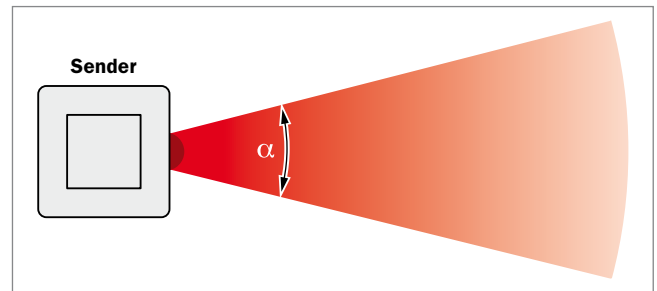

Fig. aperture angle of sender

Automatic teach

Automatic teach enables automatic teach-in of switching thresholds when the ALG is powered on.

B

Basic functions

Basic functions are functions that can be selected by customers in the MLG setup software to handle their specific application, such as the height measurement function LBB (Last Beam Blocked).

Beam coding

The beam coding is typically used with several light grids arranged side-by-side to ensure trouble-free operation. This in particular affects systems with optical synchronization. Mutual interference of several senders and receivers can thus be minimized.

F

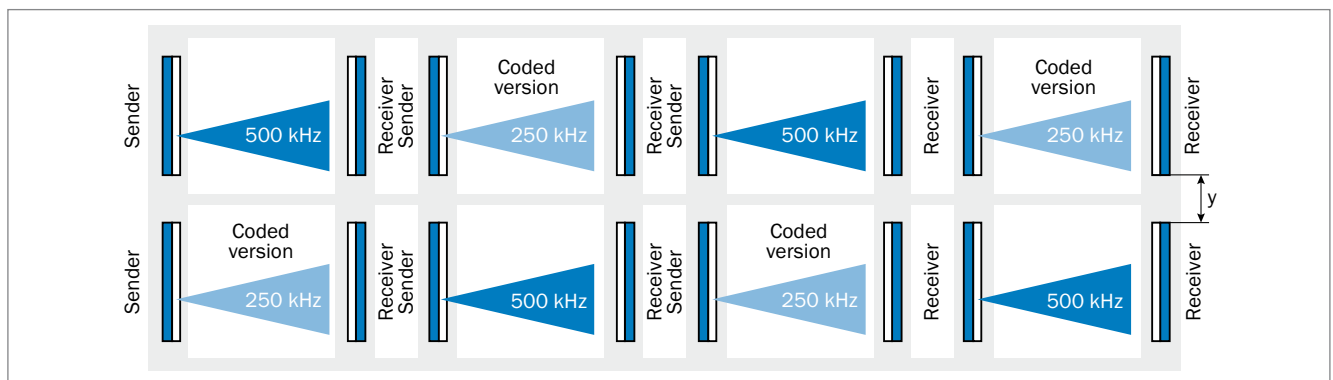

Fig. beam coding

Beam separation

The beam separation is the distance between the beam axes of two adjacent beams. The beam separation determines the ALG's resolution.

- ▶ see resolution on page F-8
- ▶ see fig. light grid construction on page F-5

Blind zone

The blind zone is the distance from the first or last beam to the edge of the housing in which an object cannot be detected.

- ▶ see fig. light grid construction on page F-5

Bus system

The bus system is a system for transferring data between several participating devices via a common cable. It allows high data transmission rates and central control of all sensors. Additional information such as process data, service data and diagnosis data can also be exchanged.

C

CAN

The CAN (Controller Area Network) is an asynchronous, serial bus system. It connects several devices with equal rights such as sensors and actuators. The data is transmitted by means of identifiers. Due to its high level of resistance to interference, real time capabilities and low costs, CAN has become an established technology in many safety-relevant areas such as automotive and automation technology. CAN is based on layer 2 according to the OSI model.

CANopen®



CANopen® is a CAN-based communication protocol. It enhances the CAN bus with a protocol structure. According to the OSI model, CANopen® is based on layer 7.

Conformity

When all relevant product safety directives are met for the relevant market, we can talk about conformity. There are essentially two binding laws within the EU for ALGs:

- EMC Directive 89/336/EEC
- Low Voltage Directive 73/23/EEC



By affixing the CE mark to the product SICK, as the manufacturer, declares the requirements set out in these directives to be fulfilled.

Connection cable

Connection cables have various properties depending on their shielding material:

PVC cable

Standard material for industrial applications.

PUR cable

for special ambient conditions:

- oil-resistant
- resistant to drying out and formation of cracks

Movement of connection cables at low temperatures must be prevented as there is a risk of breaking.

Connection diagram

Wire colors are abbreviated as follows in the sensor connection diagram:

- blk = black 
- blu = blue 
- brn = brown 
- gra = gray 
- grn = green 
- ora = orange 
- pnk = pink 
- red = red 
- trq = turquoise 
- vio = purple 
- wht = white 
- yel = yellow 

The following abbreviations are used for the assignment:

- AT = blanking input
- L+ = power supply (positive pole of power supply)
- M = ground (negative pole of power supply)
- nc = not connected
- Teach = external teaching input
- Test = test input
- Q; /Q = switching output/switching output inverted (may have additional coding or numbers)
- Q_A = analog output

Cross beam

Cross beam technology is when a beam from one sender crosses over several receivers. This enables a higher resolution, at least in the central area between sender and receiver. With ALGs, triple cross beam technology is used in most cases. A higher number of beams results in a higher light grid response time.

- ▶ see fig. light grid construction on page F-5

D

Dark switching

- ▶ see light/dark switching on page F-5

Data interfaces

SICK ALGs are equipped with the following serial interfaces via which data can be transferred:

- RS-485 for data transmission
- RS-232 as a configuration interface for MLG setup software
- PROFIBUS
- CANopen®

Detection height

The detection height is the distance between the first and the last beam of the ALG. It thus denotes the height of the monitored area in which the object has to be located to be reliably detected.

► see fig. light grid construction on page F-5

Detection of partially-translucent objects

Partially-translucent objects can only be reliably detected in the monitored area if the switching threshold is set accordingly (sensitive).

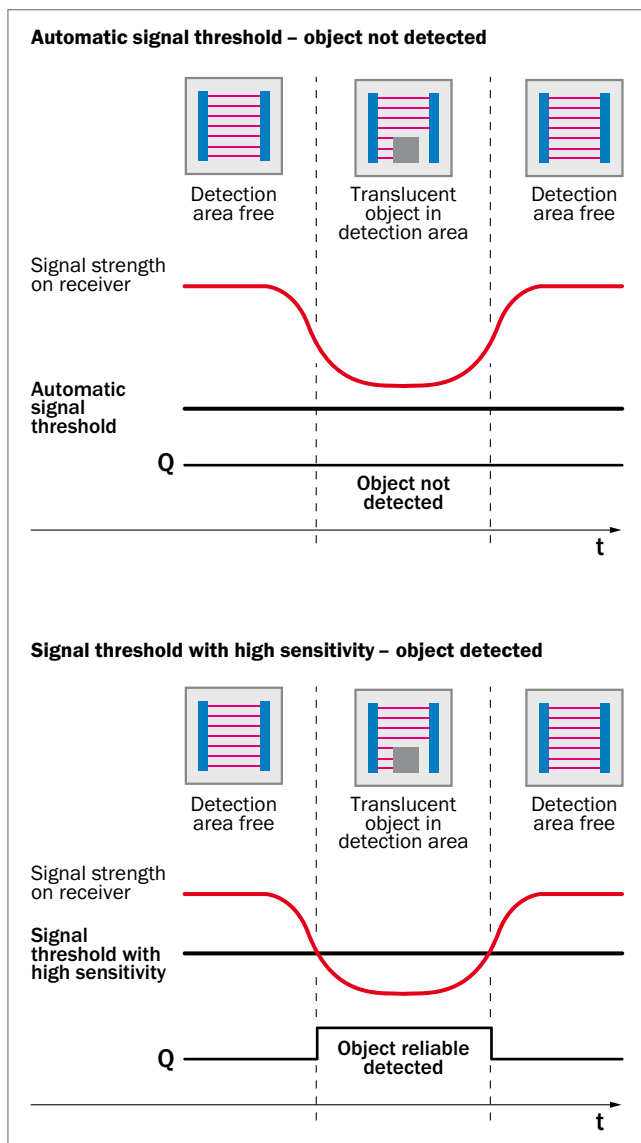

Fig. detection of partially-translucent objects

E

EDS file (CANopen®)

For use of CANopen® devices, electronic data sheets known as EDS files are required. The data they contain describes all the available parameters such as basic functions or beam statuses in a standardized text format. This enable simple configuration of the light grid by the user.

EMC

Electromagnetic compatibility (EMC) is the idea that technical devices should not be subject to interference due to electromagnetic effects. This status is attained on the one hand by restricting sources of interference in devices and on the other by designing devices to be sufficiently immune. EMC is regulated by EU Directives and Standards. SICK light grids are subject to additional in-house standards, which are stricter than the legal requirements.

Enclosure rating

The IP enclosure rating indicates the extent of a device's protection against contact with impurities such as dust or water. The code starts with the letters IP and is followed by the first digit, which is an ascending indicator of the degree of protection against contact and impurities while the second digit is an indicator of protection against ingress of water.

► see fig. enclosure rating on page F-10

F

Flat

► see slim on page F-8

G

GSD file (PROFIBUS)

GSD files are required for the use of PROFIBUS devices. Device data and parameters are stored in these. Users can also use them to set the desired parameters.

H

Housing material

ALG housings by SICK may be made of the following materials:

- Aluminum, anodized
- Plastic (ABS)
- Plexiglass (PMMA) – ALG front screens

In case of frequent or long-term effects of chemicals on light grids, an application test will be required.

I

Impact load

The impact load confirms that a test has been carried out to verify mechanical stability of the device. There are various tests here as well as the vibration resistance test.

► see vibration resistance on page F-9

1. Shock:

This test comprises single shocks induced on all x, y and z axes. The shock is exerted in both directions of movement for each axis.

2. Continuous shocks:

The same test is carried out here as in 1 but over a longer period of time (time is normally specified too). Continuous shocks are always performed with small accelerations e.g., just 10 g.

3. Sine-wave test:

With this test a mechanical sine-wave is induced on all axes of the device, x,y and z.

At the end of the test, no damage must be evident on the unit under test.

Initialization period

The initialization period is the time the light grid requires to be ready for operation once the supply voltage has been powered on.

J

Job LED

A job LED is a visible light designed to reliably guide the person responsible during the picking process. A job LED may be used for various functions. It can indicate both correct and incorrect intervention on the part of the picker using various colors or display durations. SICK's pick-to-light light grids are ready-equipped with integrated job LEDs.

► see operator guidance on page F-6

L

LED

Light emitting diodes (LEDs) are semiconductors that generate light of a certain wave length as a result of an electric simulation. The wave length is determined by the chemical composition of the semiconductor. With sender/receiver systems, LEDs in the invisible infrared wave length are primarily used as a beam source whereas, with reflection systems, LEDs in the visible red light range are used.

Light grid

A light grid enables monitoring across a wide area via a sequence of light beams.

Light grid construction

Fig. light grid construction

- ① Sender
- ② Receiver
- ③ Parallel beam
- ④ Cross beam
- ⑤ Range (working/limiting range)
- ⑥ Resolution/beam separation
- ⑦ Detection height
- ⑧ Blind zone

Light/dark switching

Sensor setting that can be used to invert the logic of the output. The terms light or dark switching are based on the point of view of the receiver element. With the "light switching" setting, the switching output (Q) is activated as soon as the receiver element receives more light than the set switching threshold. With the "dark switching" setting, the switching output (Q) is activated when the receiver element receives less light than the set switching threshold.

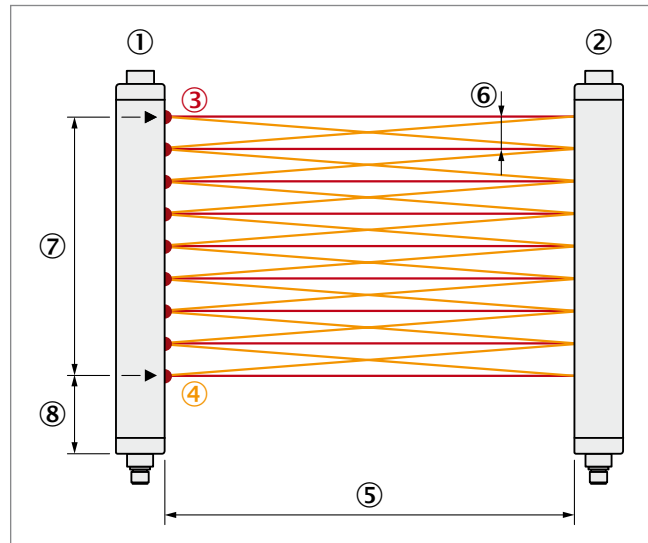
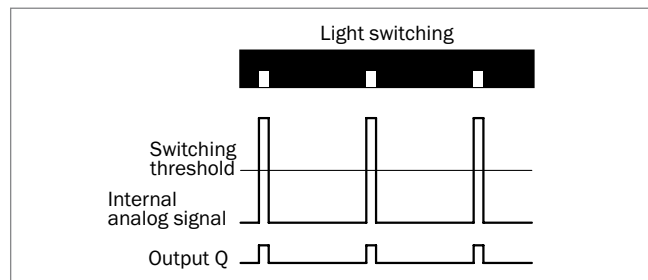

Fig. light switching

► see fig. dark switching on page F-6

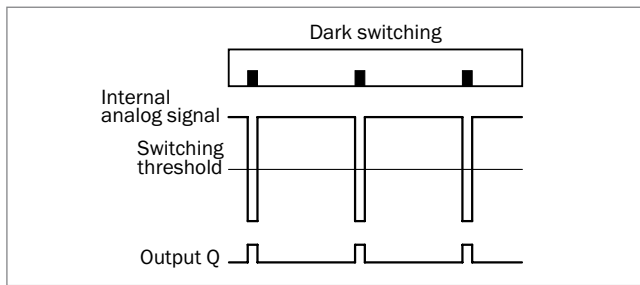

Fig. dark switching

Limiting range

The limiting range is the distance between sender and receiver or between sensor and reflector (on retro-reflective light grids) at which stable and reliable functioning can no longer be guaranteed. The limiting ranges stated constitute typical values in each case. We therefore recommend observing the recommended working range.

- ▶ see working range on page F-9
- ▶ see fig. range on page F-9

M

MDO

The MDO (Minimum Detectable Object) specifies the relevant minimum object size that must be detected at each point in the monitored area. In most cases this corresponds to the sum of the beam separation and the beam bundle diameter. Use of cross beam technology means the resolution in the ALG's central area is better than the MDO specification.

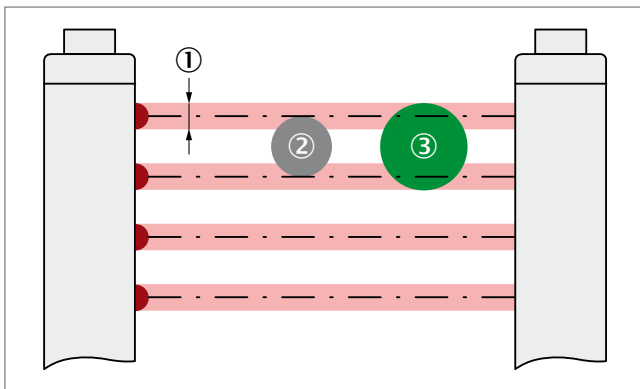

Fig. MDO

- ① Beam diameter
- ② Detection not reliable
- ③ MDO: Reliable detection

Measuring light grid



A measuring light grid detects the state of all individual beams. More complex tasks other than simple object presence may be carried out with a measuring light grid, such as location definition.

Minimum presence time

The minimum presence time specifies the minimum time an object needs to remain in the sensor's monitored area to be reliably detected.

- ▶ see fig. response time and minimum presence time on page F-8

Modular

Many ALGs have a modular construction and are therefore available in various detection heights, beam separations, interfaces and ranges.

Muting function

A muting function enables automatic blanking of a beam that has been interrupted over a long period of time e.g., due to contamination. This is an optional function with certain SICK ALGs.

N

nc

This abbreviation has the following meanings depending on its context:

- In the context of relays: normally closed
- In the context of connection diagrams: not connected.

NPN output

When the output is energized, the state of output Q changes from high-impedance to 0 V.

The output signal is therefore drawn to the negative pole of the supply voltage (ground). The load accordingly has to be connected between L+ (24 V) and the output.

O

Operator guidance

Due to the high number of assembly process variants, a multitude of manuals are required for the operator. Using SICK's pick-to-light solutions, operators are guided through the picking process safely by a light grid with a colored job LED and intervention warning so that assembly errors are reduced reliably.

- ▶ see job LED on page F-5

Optical synchronization

- ▶ see synchronization on page F-8

Output weak signal

Mist, dust, dirt, water spray, and cleaning solvents are just a few of the things that can result in deposits forming on the sensor optics or reflectors over time. This causes the level of received light to fall near the switching threshold. If the level drops below this threshold, the light grid will false trip and no longer be reliable.

To give the user an early warning of an impending device failure due to contamination, some SICK devices are equipped with a pre-failure signaling output known as an output weak signal. This reacts when the receiving light strength is just above the switching threshold. In case of contamination, the integrated yellow display LED will begin to flash on some light grids.

P

Parallel beam

Parallel beam technology is standard on SICK ALGs. In each case, the receiver located exactly opposite is assigned to the emitted beam. There are also ALGs that can alternatively be ordered with cross beam technology or else designs on which customers can configure the operating mode themselves.

- ▶ see cross beam on page F-3
- ▶ see fig. light grid construction on page F-5

Picking

Picking is the process of choosing parts (articles) and products from an overall available range of objects (sortiment) to fulfill orders or for assembly.

Pick-to-light light grid

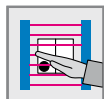

Pick-to-light light grids are used in the automotive industry on assembly lines but also for picking in the logistics sector to prevent incorrect assembly and erroneous selection. To simplify the assembly process, the order of the parts to be assembled is specified by a control. The relevant storage bin for object removal may be shown by a bright (green) job LED and incorrect picking by the worker by another (red) job LED for example. Pick-to-light light grids are used to make a considerable contribution to the attainment of high quality standards.

- ▶ see job LED on page F-5

PNP output

When the output is energized, the state of output Q changes from high-impedance to 24 V.

The output signal is therefore drawn to the positive pin of the supply voltage. The load accordingly needs to be connected between M (0 V) and the output.

Polarizing filter

Retro-reflective light grids aligned to a reflector detect the presence of objects when the light path is interrupted (i. e. the retro-reflection fails to return), thereby triggering a switching signal. Since objects to be detected may also have shiny or reflective surfaces – such as stainless steel, aluminum, or tin – the possibility of missed detection and erroneous switching as a result needs to be reliably reduced. This is achieved effectively by the use of polarizing filters.

Principle of operation

- ▶ see retro-reflective light grid on page F-7
- ▶ see sender/receiver system on page F-8

PROFIBUS



PROFIBUS (Process Field Bus) is a standard for fieldbus communication in automation technology. Specification of standards in Germany is regulated via the PNO (PROFIBUS Nutzerorganisation/user organization). Some SICK ALGs are equipped with a PROFIBUS interface.

Programmable

Programmable ALGs are available from SICK. Programming is performed via the MLG setup software. This can be downloaded from www.sick.com.

Protection class

Electrical equipment is classified in relation to existing safety measures for prevention of electric shocks. Protection classes are defined in DIN EN 61140. There are four protection classes ranging from “Basic insulation” (Class 0) to “Safety extra-low voltage (Class 1), double insulation (Class 2), safety transformer” (Class 3). All SICK ALGs have at least protection class 2.



Protection class 1



Protection class 2



Protection class 3

R

Retro-reflective light grid

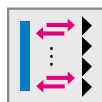

Retro-reflective light grids work according to the principle of retro-reflection. With these, a reflector is mounted opposite the sender and reflects the light emitted back to the sensor's receiver element.

Relays

Relays are electrical/mechanical switches. They are used for switching electrical circuits on, off or over. Certain types of ELG Long Range by SICK are equipped with a relay output.

Reproducibility (R)

Reproducibility (R) describes the repeat accuracy of an ALG in relation to the object entering the monitored area and the resultant response time of the switching output.

Resolution

With light grids, resolution is determined by the beam separation. The less distance between the beams, the higher the resolution. It is important to note the MDO (Minimum Detectable Object) (► see MDO on page F-7) in this context.

► see fig. light grid construction on page F-5

Response time

Response time is the time between when an event occurs (set threshold is exceeded) and the sensor switches (switching operation). An example of an event is a package entering the area monitored by the light grid. The minimum presence time also needs to be observed in this context.

► see minimum presence time on page F-6

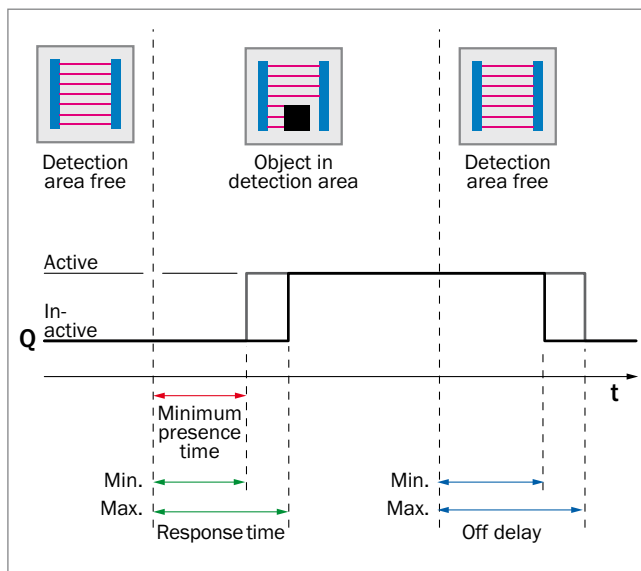
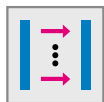

Fig. response time and minimum presence time

S

Sender/receiver system



A light grid comprises two separate devices, the sender and the receiver. This separate construction enables long ranges.

Sensitivity

Sensitivity describes the switching characteristics of the sensor with different objects or in different ambient conditions. With ALGs, sensitivity is determined by regulation of the switching threshold. This is regulated by setting a potentiometer or by means of various teach-in methods.

Slim

Smart light grids come in two designs: slim or flat. With the slim version, light emission takes place on the narrow side of the sensor while with the flat version it takes place on the flat side.

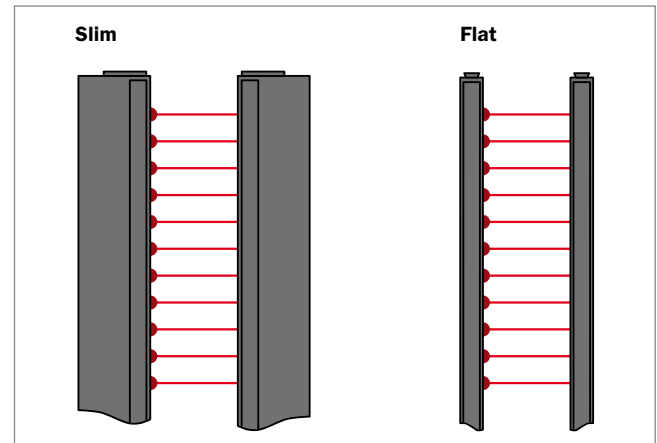
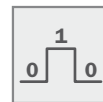

Fig. slim and flat

Switching light grid



A switching light grid has a simple switching function: In case at least one or more beams are interrupted, the switching output reacts and transfers the information "Monitored area interrupted".

Switching output

A switching output is the output via which the output state of the sensor is digitally output. SICK ALGs are equipped with various types of switching outputs:

- NPN
- PNP
- Relays

Synchronization

Synchronization with ALGs is the sequential, unique allocation of each sender element to the relevant receiver element (beams). This either happens optically by one or several light beams (sync beam) or via an electrical connection by attaching a connection cable between sender and receiver. With retro-reflective light grids, synchronization is integrated in the sensor.

T

Teach-in

With teach-in, switching thresholds of all beams are taught in automatically and individually. The following options exist for teaching in:

- Actuation of teach-in button: SLG
- Automatic teach: SLG, MLG
 - ▶ see automatic teach on page F-2
- Teach-in input: MLG, WLG, HLG, SLG
- MLG Setup: MLG Programmable, MLG Analog Output
- No teach-in required: PLG, ELG (threshold setting is via potentiometer)

The benefit of teach-in:

The switching threshold is set electronically instead of by using a potentiometer, which simplifies and speeds up commissioning of the sensor or adjustment to new applications. Particularly with light grids, this is a highly suitable method since each light beam is set individually and optimally.

Test input

The emitted light is switched off when the test input is activated, simulating a beam interruption.

Type code

In the type code, all possible light grid variants are sorted in a list according to properties. This enables users to assemble light grid properties which are suited to their requirements.

Terminals

The terminals enable cables to be guided via a sealed cable gland before being connected to the light grid. This enables use of up to six switching outputs and two inputs with ALGs.

W

Working range

The working range is the maximum recommended range between sender and receiver or between sensor and reflector (retro-reflective light grids) at which stable and reliable operation is guaranteed.

▶ see limiting range on page F-6

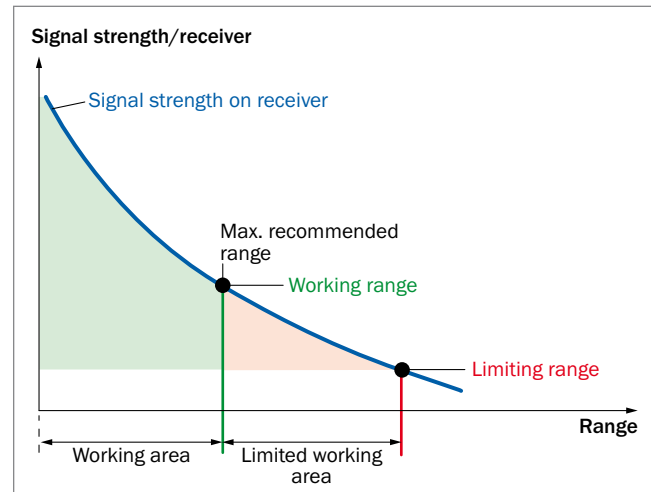

Fig. range

V

Vibration resistance

Vibration resistance is confirmed in a test according to the DIN standard.

Vibration, broadband noise: test according to DIN EN 60068-2-64:

With this test an arbitrary mechanical sine wave is induced on all axes of the device x, y and z. A random acceleration, e.g. 5 grms (statistical mean value) and a valid frequency range e.g. 10 Hz to 150 Hz are specified. The test time is likewise specified and is typically 100 min for each axis.







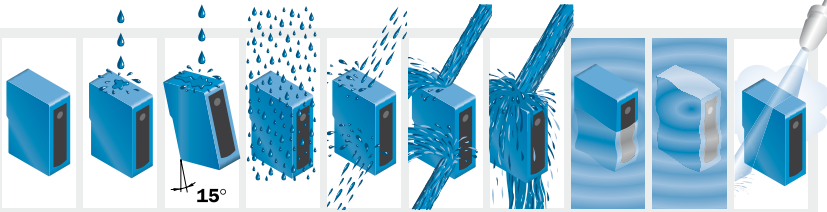

<p>2nd digit: Protection against ingress of water</p> 											
		No protection	Drip-water vertical	tilted	Spray water	Splash water	Jet water	Strong jet of water	Temporary immersion	Lasting immersion	100 bar, 16 l/min., 80 °C
<p>1st digit: Protection against ingress of foreign bodies</p>											
IEC 529 DIN 40050		IP...0	IP...1	IP...2	IP...3	IP...4	IP...5	IP...6	IP...7	IP...8	IP...9K
<p>IP 0... No protection</p> 	IP 00										
<p>IP 1... Size of foreign body ≥ 50 mm Ø</p> 	IP 10	IP 11	IP 12								
<p>IP 2... Size of foreign body ≥ 12 mm Ø</p> 	IP 20	IP 21	IP 22	IP 23							
<p>IP 3... Size of foreign body ≥ 2.5 mm Ø</p> 	IP 30	IP 31	IP 32	IP 33	IP 34						
<p>IP 4... Size of foreign body ≥ 1 mm Ø</p> 	IP 40	IP 41	IP 42	IP 43	IP 44						
<p>IP 5... Dust-protected</p> 	IP 50			IP 53	IP 54	IP 55	IP 56				
<p>IP 6... Dust-proof</p> 	IP 60					IP 65	IP 66	IP 67			IP 69K

Fig. enclosure rating

More information about our products is available online:

www.mysick.com

Product  **Finder**

www.mysick.com/Products

The Product Finder lets you search for the suitable device for your application using your specification – from a large number of products in all areas of factory and logistics automation.

Applications  **Finder**

www.mysick.com/Application

You can select an application description for your particular task, market or product group with the Applications Finder.

Literature  **Finder**

www.mysick.com/Literature

You can access all publications in the Literature Finder, e.g. operating instructions, technical information, customer magazines and other literature about SICK products.



Partner Portal

www.mysick.com

An online portal is essential when efficient and fast processing of each detail is important!

Benefit from the SICK Partner Portal.

- User-friendly
- 24-hour availability
- Secure

SICK at a glance

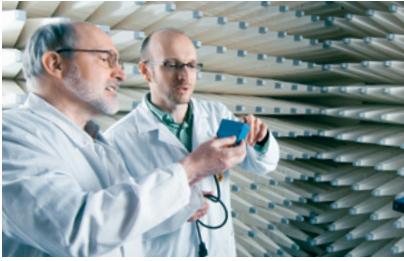

Leading technologies

With a staff of more than 5,000 and over 50 subsidiaries and representations worldwide, SICK is one of the leading and most successful manufacturers of sensor technology. The power of innovation and solution competency have made SICK the global market leader. No matter what the project and industry may be, talking with an expert from SICK will provide you with an ideal basis for your plans – there is no need to settle for anything less than the best.



Unique product range

- Non-contact detecting, counting, classifying, positioning and measuring of any type of object or media
- Accident and operator protection with sensors, safety software and services
- Automatic identification with bar code and RFID readers
- Laser measurement technology for detecting the volume, position and contour of people and objects
- Complete system solutions for analysis and flow measurement of gases and liquids



Comprehensive services

- SICK LifeTime Services – for safety and productivity
- Application centers in Europe, Asia and North America for the development of system solutions under real-world conditions
- E-Business Partner Portal www.mysick.com – price and availability of products, requests for quotation and online orders

Worldwide presence with subsidiaries in the following countries:

Australia
Belgium/Luxembourg
Brasil
Česká Republika
Canada
China
Danmark
Deutschland
España
France
Great Britain
India
Israel
Italia
Japan

México
Nederland
Norge
Österreich
Polska
România
Russia
Schweiz
Singapore
Slovenija
South Africa
South Korea
Suomi
Sverige
Taiwan
Türkiye
United Arab Emirates
USA

Please find detailed addresses and additional representatives and agencies in all major industrial nations at www.sick.com

QUERO
AUTOMATION

GRUPO QUERO JC-ELECTRONICS SPAIN, S.L.U.
C/ REGORDOÑO, 13
28936 - MÓSTOLES - MADRID

+34 91 685 24 03
+34 91 685 24 04

info@queroautomation.com